

MONOBLOCK VALVE VDM8

Technical catalogue

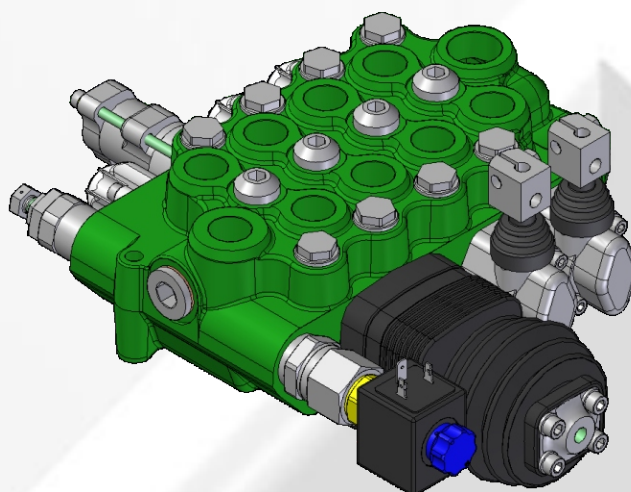

E0.01.0911.02.03

COMPANY
WITH QUALITY SYSTEM
CERTIFIED BY DNV
=ISO 9001/2000=



Page 1 - GENERAL INDEX

Page 2 - General features

Page 3 - Technical data - Working conditions

Page 4 - Operating principle

Page 5 - Installation - Filtration - Pipes

Page 6 - Performance data - Metering curves - Valve working limit

Page 7 - Performance data - Pressure drop "P" to "T" - Pressure drop "P" to "A/B" and "A/B" to "T"

Page 8 - Dimensions from 2 to 5 sections monoblock

Page 9 - Dimension for 1 section monoblock

Page 10 - Hydraulic fluid - Ports

Page 11 - Inlet and outlet types

Pages 12 - 13 - Circuit and spool types

Page 14 - Main relief valves

Page 15 - Venting valves

Pages 16 - 17 - Auxiliary valves

Page 18 - Spool controls and spool positionings

Page 19 - Spool controls - SL- NL - NP - MP

Page 20 - Spool controls - SS - FL

Page 21 - Spool controls - L1/L2 - Standard shafts

Page 22 - Rotary control devices - CR

Page 23 - Cable remote controls - D1 - TC

Page 23 - Direct electric push-pull control and emergency devices - E1/E2 - SL - ES

Page 24 - Hydraulic controls - IP - IF

Page 25 - Pneumatic and electro-pneumatic controls - PP/P0 - P1/P2 - PQ

Page 26 - 27 - Electro-hydraulic controls - H1/H2

Page 28 - Spool positionings - C2 -C3 - C4 - C5 - C6 - C7 - C8

Page 29 - Spool positionings - R2 - R4 - R5 - R6 - R7 - R9 - C0

Page 30 - Spool positionings - F1 - F2 - F3 - F4 - F5 - F6 - F7 - F8

Page 31 - Spool positionings - D7 - D8 - D9 - M1 - M2 - M3

Page 32 - Spool positionings - CE - CM - CW - CD

Page 33 - Spool positionings - PM - G2 - G4 - G5

Page 34 - How to order - VDM8

Page 35 - Identification label

Page 36 - WARRANTY

E0.01.0911.02.03

The data in this catalogue refers to the standard product.

The policy of Salami S.p.A. consists of a continuous improvement of its products. It reserves the right to change the specifications of the different products whenever necessary and without giving prior information.

If any doubts, please get in touch with our sales department.

GENERAL FEATURES

Among all hydraulic directional control valves used in the field of mobile equipment applications, the spool valve is the most popular.

The monoblock valve type offers an excellent performance price ratio.

FEATURES

VDM8 directional control valve has the following:

- cast-iron monoblock construction up to 5 spools
- parallel circuit, load check valve protection on each section
- possibility of venting valve
- possibility of power beyond configuration
- spool construction in steel, hardened and chromium-plated to obtain a higher surface hardness and a better corrosion resistance
- several types of spool: double, single acting, spool motor, float position etc.
- minimum tolerance between the spools and the body to obtain a minimum internal leakage
- interchangeability of all the spools
- possibility of auxiliary valve either on port A or B or on both
- several spool control devices and spool positioning devices

VALVE AND DEVICE TYPES

In order to meet the most stringent demands and to offer a wider range of applications, the following types of valves and devices are available:

Valves

- direct main relief valve: controls the maximum pressure in the circuit when one or more spools are on end stroke located on "A" or "B" port side, can be:
 - direct type version up to 260 bar - 3700 *psi*
 - pilot operated with anticavitation version up to 350 bar - 5000 *psi*
- electric by-pass valve: located in the opposite cavity of the main relief valve and is available as 12 or 24 Vdc and normally open or normally closed versions
- overload and anticavitation valve on port A or/and B: set at a higher value (in comparison with the main relief valve), it protects the working ports from load induced pressures, avoids cavitation in the system created by the inertia.
- anti-cavitation check valve on port A or/and B: avoids cavitation in the system created by the inertia.
- flow restrictor: directly fitted on the "A/B" ports orifice

Devices

- handle controls
- handle safety devices: avoids accidental operation of the spool
- cross lever: allows to acting two spools with one manual joystick
- cable remote control
- control device for microswitches: for the operation with electric d.c. motor driven pumps at one or more rotation speeds
- hydraulic kick-out: the spool returns automatically to the neutral position when the preset pressure of port "A" or "B" is exceeded
- anti-tilt device: the spool returns automatically in neutral position when the pressure reaches a pre-set value to avoid cranes from becoming unstable
- pneumatic proportional control
- electropneumatic control
- hydraulic proportional control
- direct electric on-off control with emergency manual device
- electrohydraulic on-off and proportional control
- several spool positionings device to return the spool to neutral position or to lock the spool on working position



TECHNICAL DATA

Spools	from 1 to 5		
Nominal flow	Q	75 l/min	(20 gpm US)
Max flow*		90 l/min	(24 gpm US)
Max pressure	port P	350 bar	(5100 psi)
	ports A/B	350 bar	(5100 psi)
	port T*	25 bar	(363 psi)
Internal leakage at 160 bar (2285 psi)	ports A/B → T	25 ÷ 35 cm ³ /min (1.52 ÷ 2.13 cu.in./min)	
For lower leakage please contact our sales dept.			
In case of solenoid control the leakage is		120 ÷ 160 cm ³ /min (7.32 ÷ 9.76 cu.in./min)	
Spool stroke (positions 1 and 2)		± 7 mm	(0,28 in.)
Spool stroke (position 4, float or regenerative)		± 7 + 5 mm	(0.28 + 0.19 in.)
For solenoid spool control - stroke		± 5 mm	(0,19 in.)
*In case you need the max flow please contact our sales dept.			
*For higher back pressure please contact our sales dept.			
All technical data carried out using mineral oil with viscosity of 16 cSt and contamination level 19/16 as ISO 4406.			

Nominal flow meaning: flow causing 1 bar (14.5 psi) pressure drop each section, with spools in neutral position

WORKING CONDITIONS

Hydraulic fluid	mineral oil according to DIN 51524		
Viscosity	viscosity range	10...400 mm ² /sec	(0.15...7.13 sq.in./sec)
	optimal viscosity	12...75 mm ² /sec	(0.19...1.16 sq.in./sec)
Temperature	fluid range temperature	-20...85 °C	(-4...185 °F) NBR seals
	suggested range	30...60 °C	(86...140 °F) NBR seals
Maximum contamination level	NAS 1683: class 9 ISO 4406: 19/16		
Room temperature	-30...60 °C (-22...140 °F)		
Working limits	see diagrams at page 6		
Pressure drop	see diagrams at page 7		
For operation with fire resistant fluid, please contact our sales department			

OPERATING PRINCIPLE

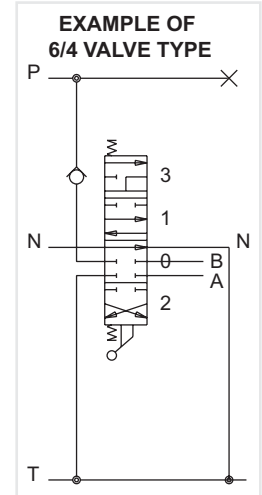
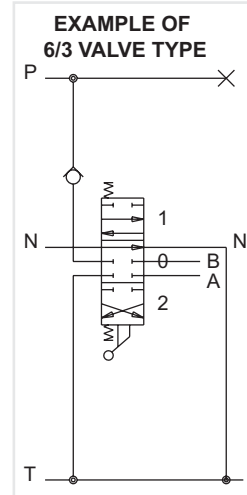
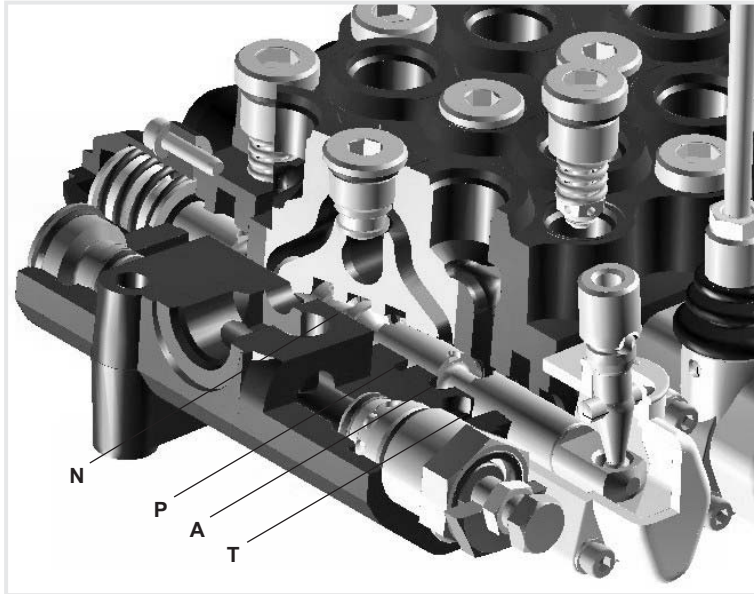

The picture show the paths N - P - A - T, the other paths are simmetrical

Salami directional control valves belong to the 6/3 (or 6/4) type; they can control 6 gallery in 3 (or 4) spool positions simultaneously.

They are open circuit types: when the spool is in neutral position, the fluid flows directly to the tank with minimum internal pressure drops (approximately 1 bar / 14.5 psi for each spool at nominal flow).

When the spool is moved from this position, the neutral gallery is gradually throttled and the connection between pump and actuator, through the corresponding port, is made.

When a pressure exceeds the value of the pressure existing in port A or B, the fluid flows through the load check valve to the actuator.

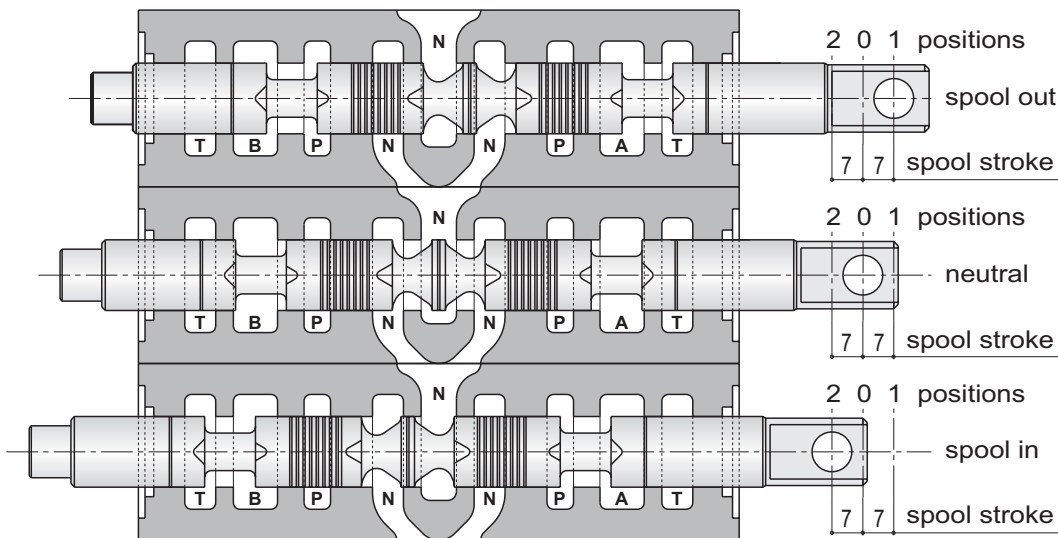

IMPORTANT

Looking at this side of the spool, we usually say: spool in when the spool is pushed into the valve and spool out when it is pulled out of the valve. Depending on assembling of the spool on "A" or "B" side

There are two characteristic phases in the spool stroke (7 mm - 0,275 in.):

a) the overlap phase (about 18% of the stroke) guarantees minimum internal leakages in neutral position;

b) the progressive flow regulation phase (82% of the stroke).

Both pictures show a 6/3 valve type with double acting spool only as principle of functioning.

Salami VDM8 is available in different solutions.

INSTALLATION

When proceeding to mount the unit on the structure and to connect fittings to work ports, it is necessary to comply with the values of tightening torques.
The attachment of linkages to spools should not affect their operation. The mounting position can be vertical with inlet module on the top or horizontal.

Standard tightening torques - Nm / lbf^t

FITTING TYPE	P and PL ports	A and B ports	T and TL ports
BSP (ISO 228/1)	G 3/4	G 1/2	G 3/4
with o-ring seal	60 / 44.2	50 / 36.9	60 / 44.2
with copper washer	70 / 51.6	60 / 44.3	70 / 51.6
with steel washer	70 / 51.6	60 / 44.3	70 / 51.6
SAE	SAE 10 (7/8-14 UNF)	SAE 10 (7/8-14 UNF)	SAE 12 (1 1/16-12 UN)
with o-ring seal	60 / 44.2	60 / 44.2	95 / 70.1

FILTRATION

The contamination of the fluid in the system greatly affects the life of the unit. Above all, contamination may result in irregular operation, wear of seals in valve housings and failures. Once the initial contamination level of the system has been reached, it is necessary to limit any increase of contamination installing an efficient filtration system (see working conditions page 3).

PIPES

Pipes should be as short as possible, without restrictions or sharp bends (especially the return lines). Before connecting pipes to the fittings of the corresponding components, make sure that they are free from burrs and other contamination.

As a first approximation, for a mobile machine with standard length pipes, their width should guarantee the following values of fluid speed*:

6 ÷ 10 m/sec
3 ÷ 5 m/sec

inlet pipe
outlet pipe

19,7 ÷ 32,8 ft/sec
9,9 ÷ 16,4 ft/sec

inlet pipe
outlet pipe

the lowest values of fluid speed are required in case of wide temperature range and/or for continuous duty.

$$* v = \frac{21,2 \times Q}{d^2}$$

v = fluid speed [m/sec], Q = flow [l/min], d = pipe internal diameter [mm]

PERFORMANCE DATA

The characteristics in this catalogue are typical measured results.
During measuring a mineral based hydraulic oil with a viscosity of 16 cSt at a temperature of 50°C was used.

FOR FURTHER DETAILS PLEASE CONTACT OUR SALES DEPARTEMENT

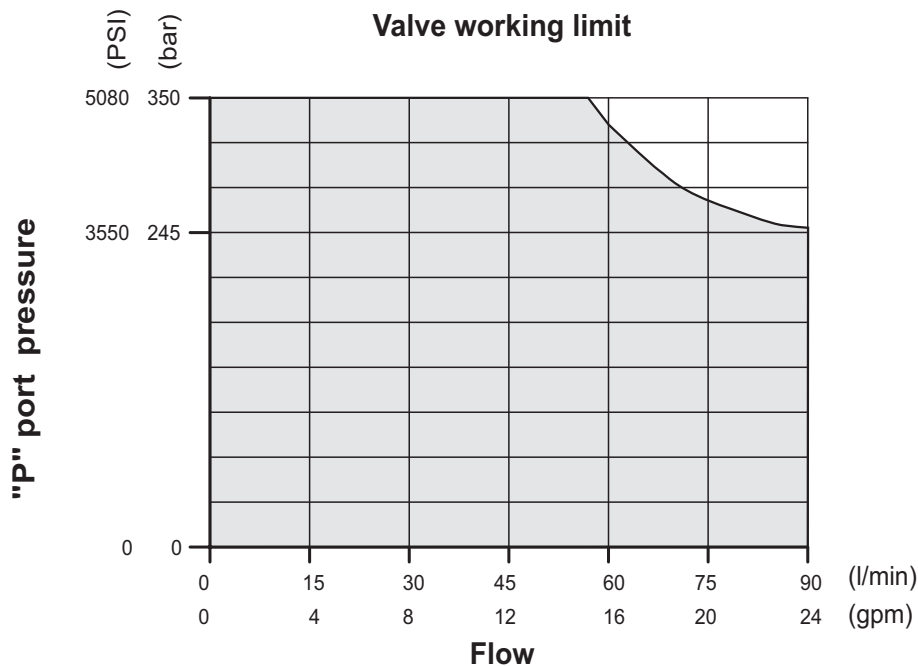
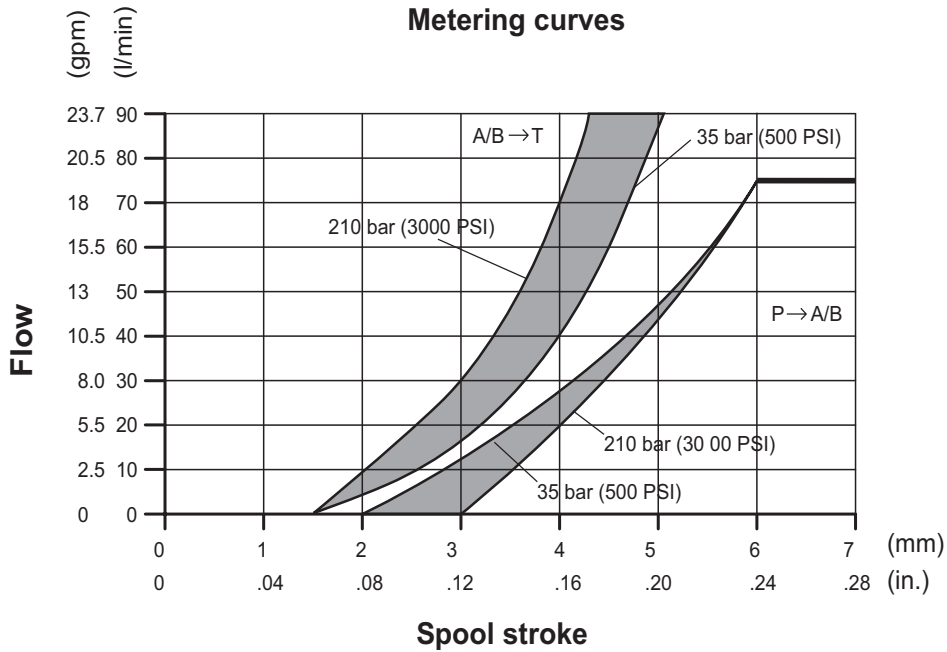

The data of this diagram have been obtained by a manual control using an effort:
stroke beginning 120 N - stroke end 180 N and standard leakage data.



PERFORMANCE DATA

The characteristics in this catalogue are typical measured results.
During measuring a mineral based hydraulic oil with a viscosity of 16 cSt at a temperature of 50°C was used.

FOR FURTHER DETAILS PLEASE CONTACT OUR SALES DEPARTEMENT

Pressure drop "P" to "T"

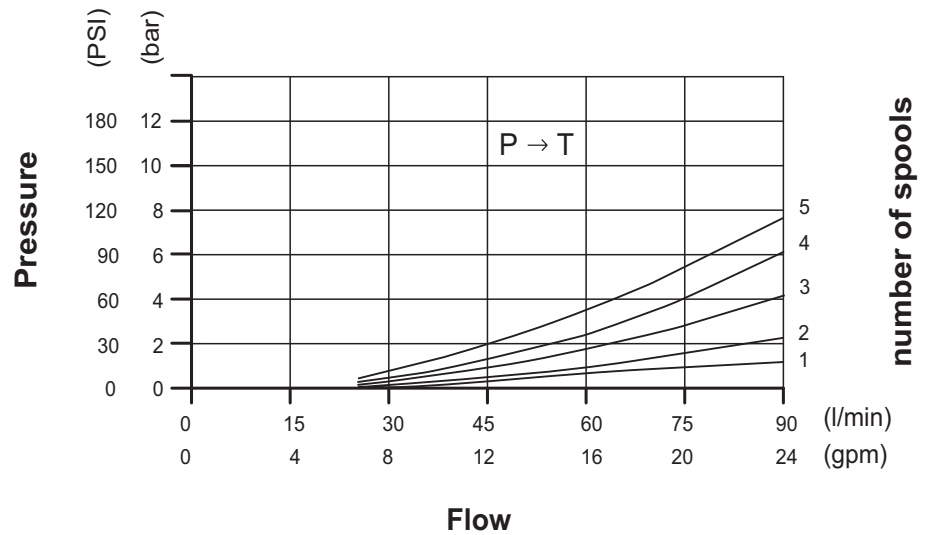
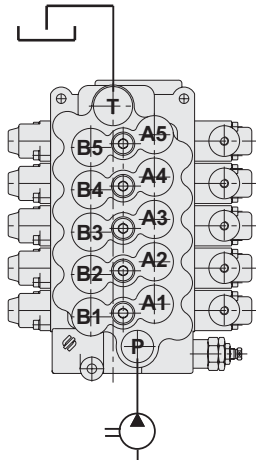

**Pressure drop "P" to "A/B1" and to "A/B5"
Pressure drop "A/B1" and "A/B5" to "T"**

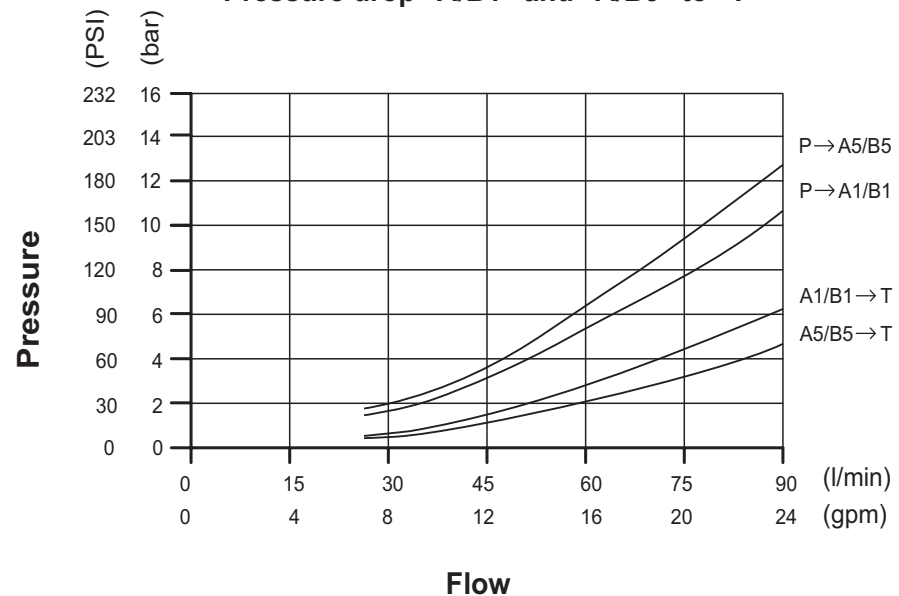
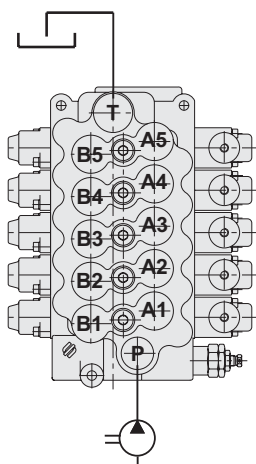

DIMENSIONS FROM 2 TO 5 SECTIONS MONOBLOCK

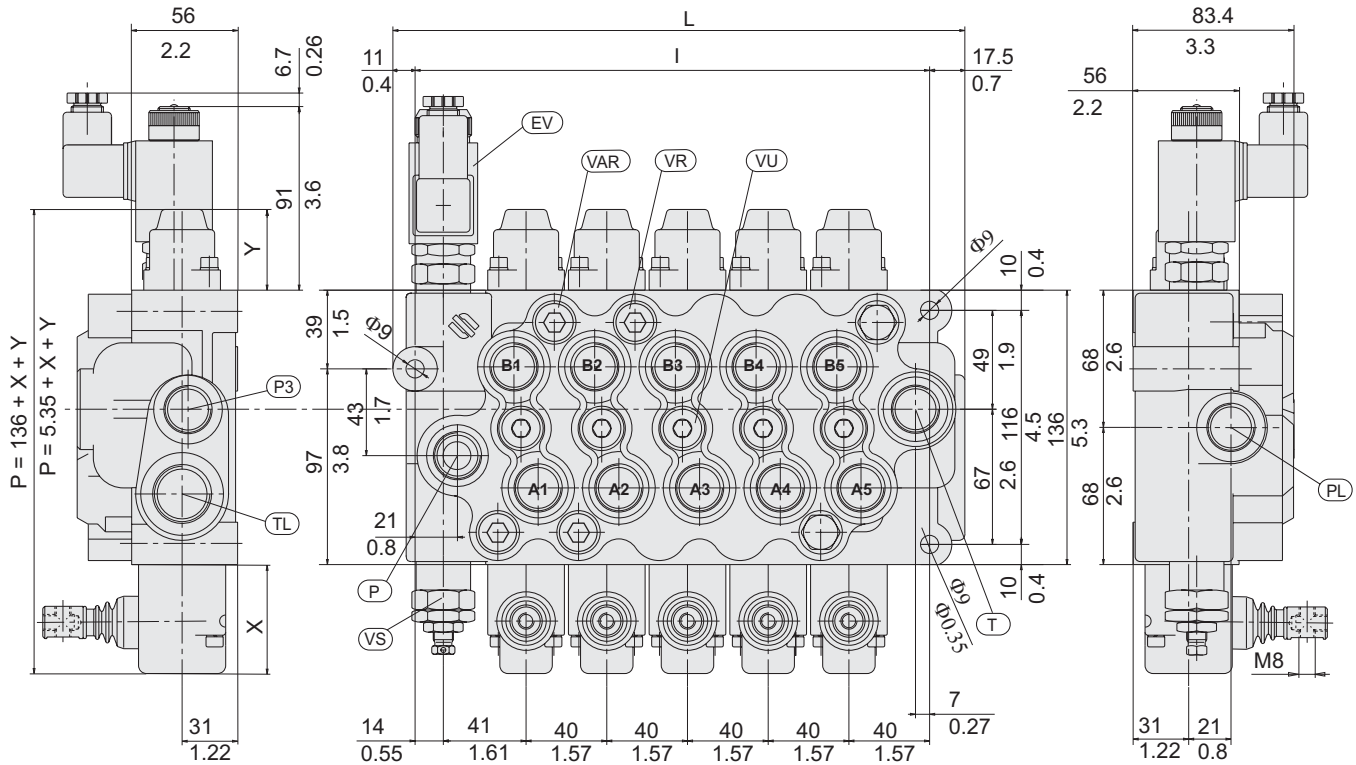

The drawing shown is just an example. The overall dimensions you read are valid for all the VDM8 except the parametric dimensions "L" and "I" depending of the number of working sections. The parametric dimension "P" depends on a fixed dimension of 136 mm (11 in.) to which you have to add the "X" and "Y" dimensions that you can find in the spool controls and spool positionings pages.

INDEX:

- P** = top inlet port
- PL** = side inlet port
- P3** = side outlet port for power beyond
- T** = top outlet port
- TL** = side outlet port
- A/B** = work ports
- VS** = main relief valve(adjustable)
- EV1** = venting valve 12 V normally open
- EV2** = venting valve 24 V normally open
- EV3** = venting valve 12 V normally closed
- EV4** = venting valve 24 V normally closed
- VAR** = overload and anti-cavitation valve
- VR** = anti-cavitation valve
- VU** = load check valve

6 spools valve not yet available

Spools		1	2	3	4	5	6
I	mm	/	135	175	215	255	/
	in	/	5,31	6,89	8,46	10,03	/
L	mm	/	163,5	203,5	243,5	283,5	/
	in	/	6,43	8,01	9,59	11,16	/

For different size and thread ports
contact our sales department

PORT SIZES	P - PL - P3	T - TL	A - B
BSP ISO 228	G 1/2	G 3/4	G 1/2
SAE ISO 176	SAE#10 7/8 - 14 UNF	SAE#12 1-1/16 - 12 UNF	SAE#10 7/8 - 14 UNF
ISO 262 - ISO 6149	M 22 x 1.5	M 27 x 2	M 22 x 1.5

DIMENSIONS FOR 1 SECTION MONOBLOCK

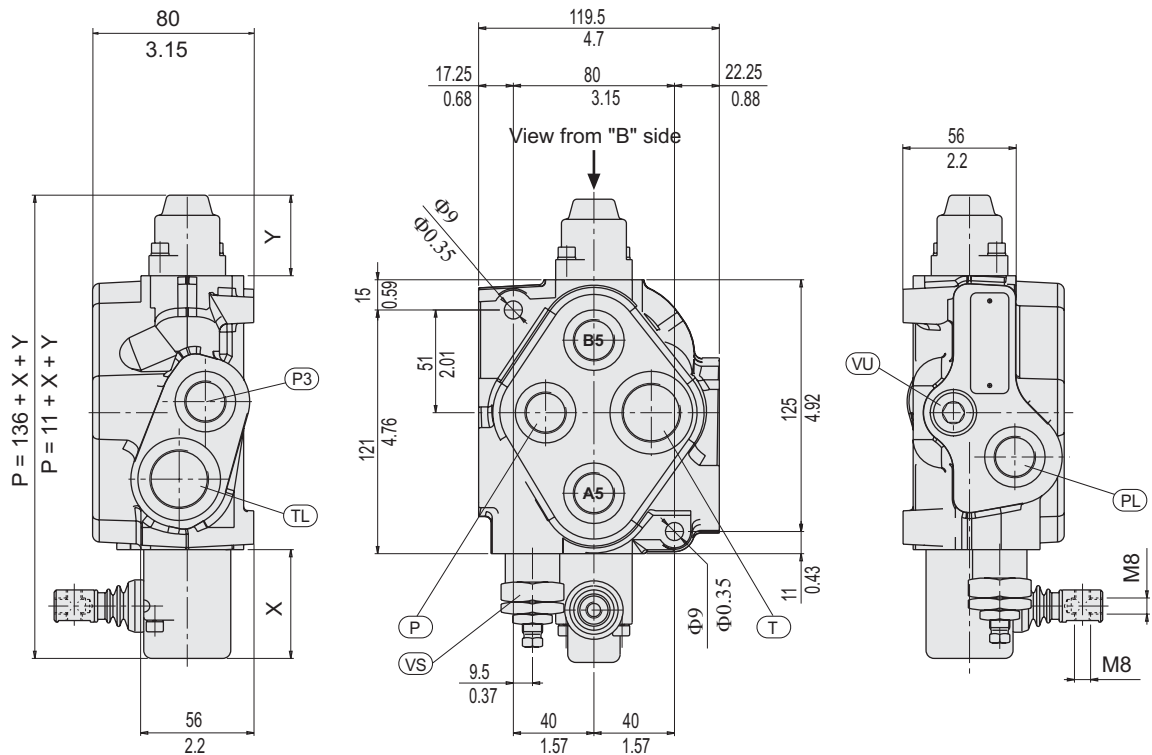

The parametric dimension "P" depends on a fixed dimension of 136 mm (11 in.) to which you have to add the "X" and "Y" dimensions that you can find in the spool controls and spool positionings pages. In this monoblock the main relief valve can be assembled only on "A" side, you can assemble venting valve option only instead of main relief and not in combination with it, moreover only on "B" side you can assemble the levers as shown in the drawings here below.

INDEX:

- P** = top inlet port
- PL** = side inlet port
- P3** = side outlet port for power beyond
- T** = top outlet port
- TL** = side outlet port
- A/B** = work ports
- VS** = main relief valve(adjustable)
- VU** = load check valve

PORT SIZES	P - PL - P3	T - TL	A - B
BSP ISO 228	G 1/2	G 3/4	G 1/2
SAE ISO 176	SAE#10 7/8 - 14 UNF	SAE#12 1-1/16 - 12 UNF	SAE#10 7/8 - 14 UNF
ISO 262 - ISO 6149	M 22 x 1.5	M 27 x 2	M 22 x 1.5

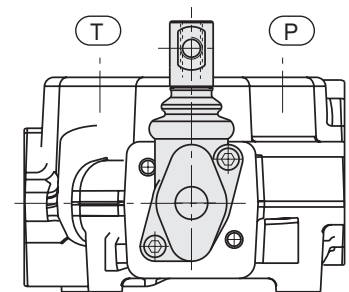

Views from "B" side

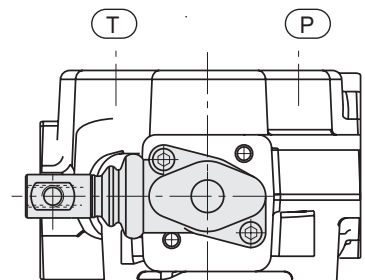

Monoblocks with all ports threaded G3/4 or SAE 12 are available, please specify in phase of order.

HYDRAULIC FLUIDS

Usually a mineral-base oil with a good viscosity index should be used, preferably with good lubricating properties and corrosion, oxidation and foaming resistant.

Sometimes the fluids supplied by the manufacturers do not satisfy purity requirements (see page 3 WORKING CONDITIONS). It is therefore necessary to filter the fluid carefully before filling. Your supplier can give you the information about NAS class of its fluids. To maintain the proper purity class, the use of filters of high dirt capacity with clogging indicator is recommended.

Under humidity conditions it is necessary to use hygroscopic salts.

For operation with fire resistant and ecological fluids, please contact our technical department.

PORTS

Following are standard ports. For different port types, please contact our sales department.

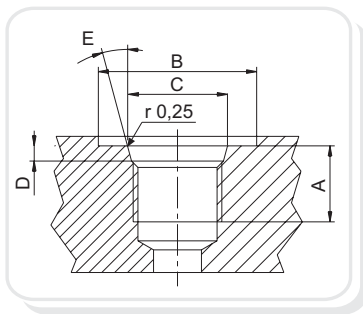

SAE UN-UNF (ISO 725)							
Dimensions		7/8 -14 UNF SAE10		1"1/16 -12 UN SAE12		1"5/16 -12 UN SAE16	
mm	In.						
A		17	0,67	20	0,79	20	0,79
B		34	1,34	41	1,61	49	1,92
C		23,9	0,94	29,2	1,15	35,5	1,40
D		2,5	0,10	3,3	0,13	3,3	0,13
E		15°		15°		15°	

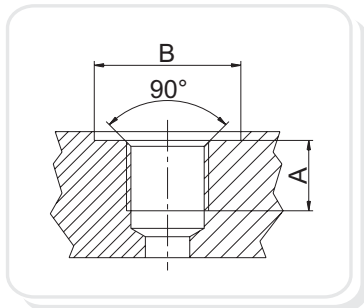

BSP (ISO 228)							
Dimensions		G1/2		G3/4		G1	
mm	In.						
A		16	0,63	18	0,71	20	0,79
B		27	1,06	33	1,30	40	1,57

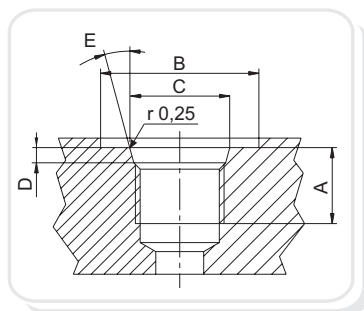

METRIC (ISO 262 - ISO 6149)*									
Dimensions		M22 x 1.5				M27 x 2			
mm	In.	ISO 262		ISO 6149		ISO 262		ISO 6149	
A		16	0,63	16	0,63	18	0,71	19	1,75
B		31,5	1,24	34	1,34	37,7	1,48	40	1,57
C				23,8	0,94			29,4	1,16
D				2,4	0,09			3,1	0,12

*Available for quantity, please contact our sales dept.

INLET AND OUTLET TYPES

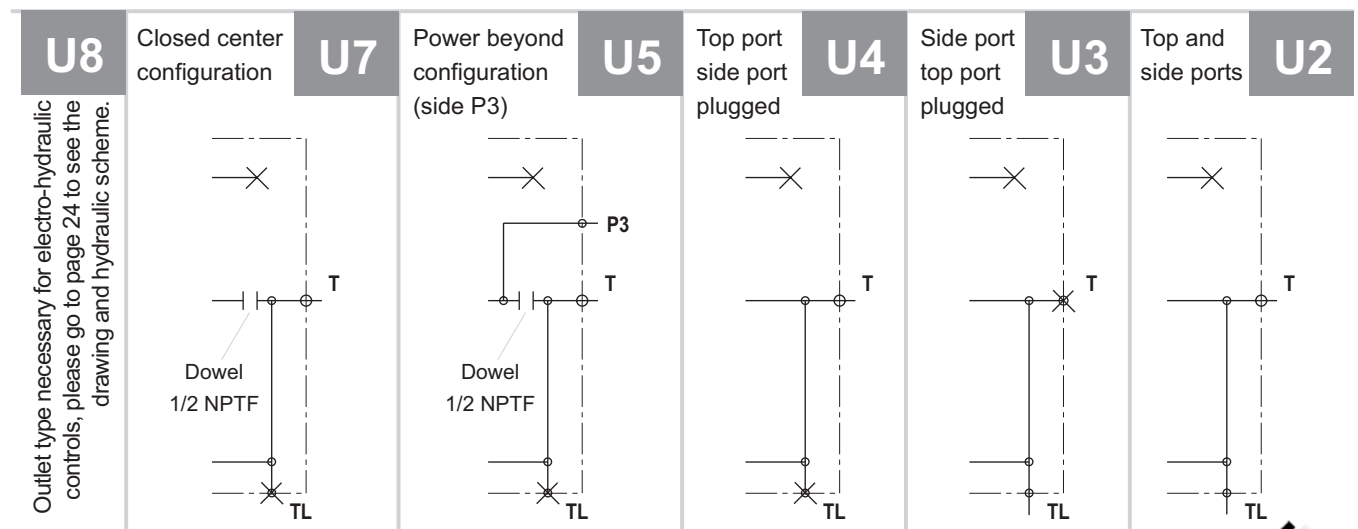
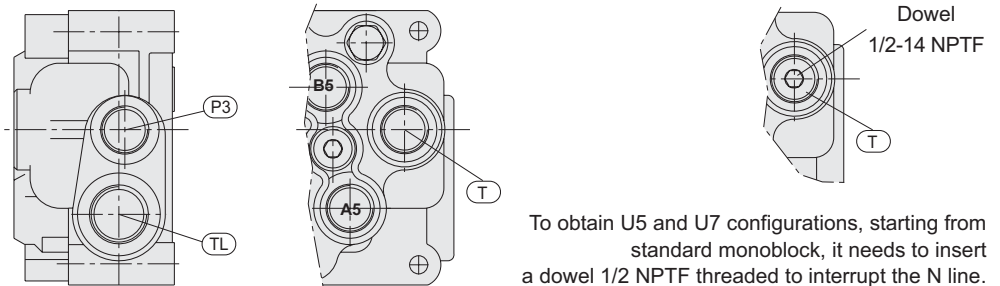
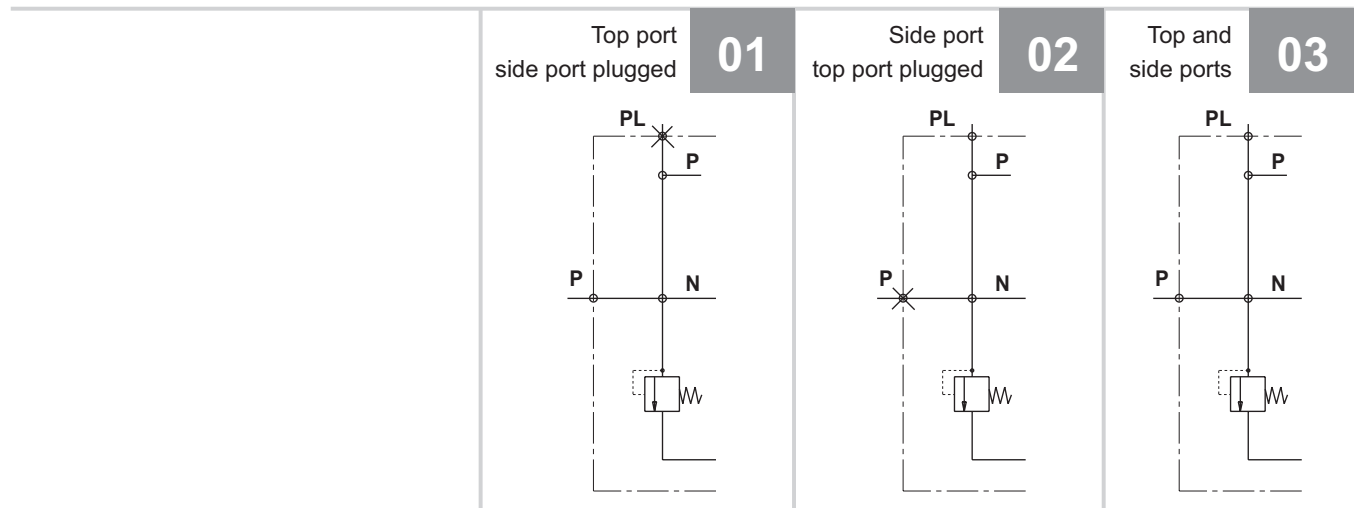
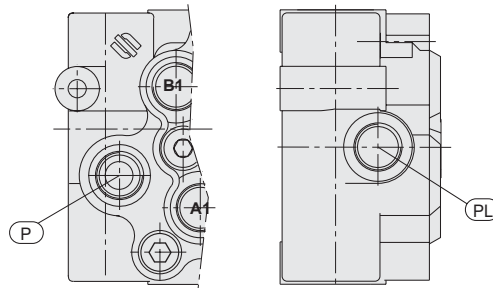

CIRCUIT AND SPOOL TYPES

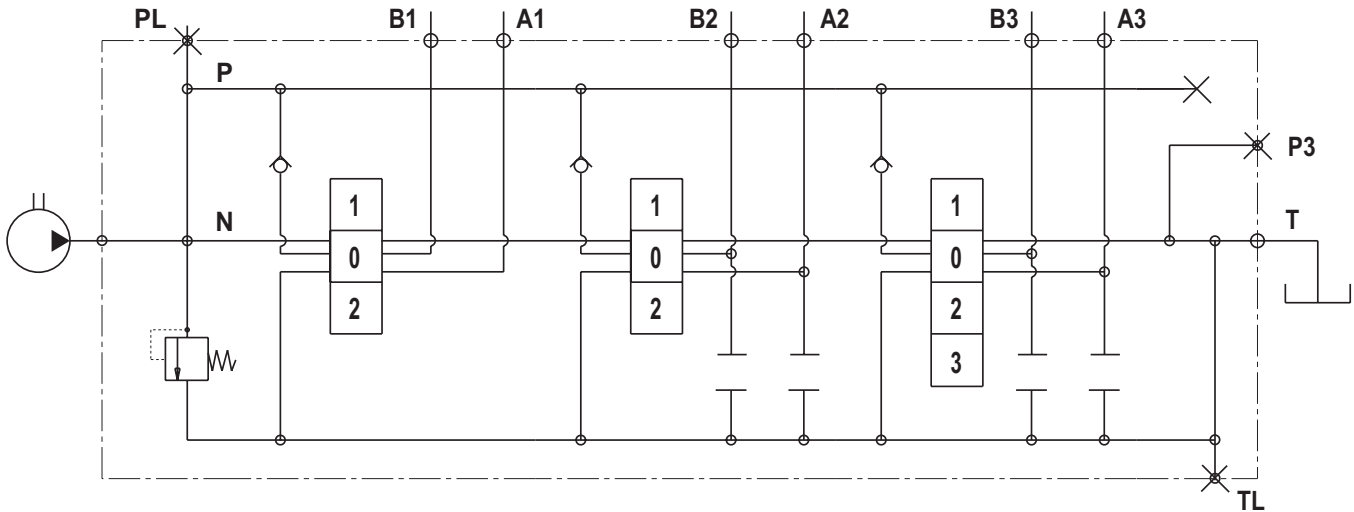

This is the standard circuit between working sections: the circuit is always parallel type, as shown in the picture above you can have main relief valve in the inlet(see page 14), the working sections can have pre-arrangement for auxiliary valves or not,

the spools can be 3 or 4 positions (as shown here below) moreover VDM8 is always pre-arranged for carry over just adding a dowel 3/8" NPTF.

As you can read at page 34, the spools can be types "A" nominal flow or "C" 2/3 of nominal flow.

01		Double acting spool	Double acting motor spool		02
03		Double acting motor spool ("B" port blocked)	Double acting motor spool ("A" port blocked)		04
05		Single acting spool "A" working port	Single acting spool "B" working port		06

<p>11</p>		<p>Double acting spool with float function in 3rd position (spool in)</p>	<p>Double acting spool with float function in 3rd position (spool out)</p>	<p>12</p>
<p>13</p>		<p>Double acting spool with regenerative function in 3rd position (spool in)</p> <p>With this type of spool a special machining of the body is required</p>		
<p>17</p>		<p>Double acting spool with regenerative function in position 2 (spool in)</p> <p>With this type of spool a special machining of the body is required</p>	<p>Double acting spool with regenerative function in position 1 (spool out)</p> <p>With this type of spool a special machining of the body is required</p>	<p>18</p>
<p>52</p>		<p>Over center double acting spool "A" working port</p>	<p>Over center double acting spool "B" working port</p>	<p>53</p>
<p>54</p>		<p>Over center double acting spool "A and B" working ports</p>		

Salami standard spools have the ends as shown in this drawing. These ends spool are necessary to join it the controls and the positionings. With direct electric and hydraulic controls the ends spool are different as you can see at pages 23 and 24.

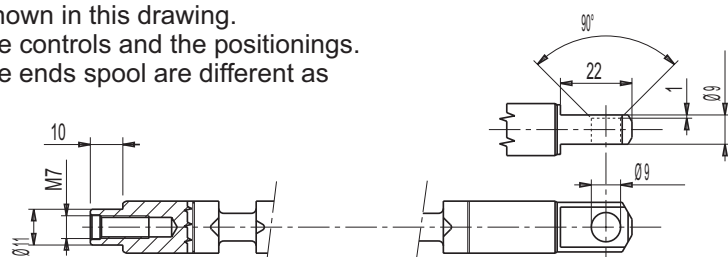

MAIN RELIEF VALVES

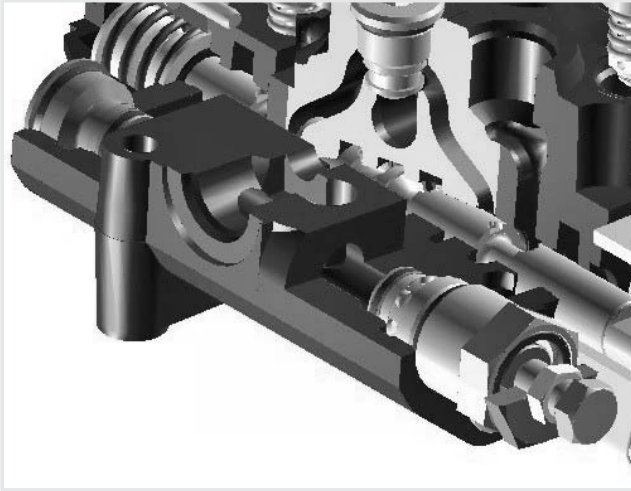

As you can see in the picture beside, the main relief valve can be mounted on "A" or "B" side because the VDM8 is always pre-arranged in this way (except the VDM8 - 1 section monoblock where the valve is always on "A" side). In the opposite side of the main relief valve you must mount a plug that you find in this page. All the testing values of this page have been obtained with nominal flow of 50 L/min - 13.21 gpm, viscosity 16cST and oil temperature 50°C - 122°F.

Max tightening torque:
 wrench 13 - 24 Nm
 wrench 17 - 27 Nm
 wrench 25 - 35 Nm
 wrench 27 - 40 Nm
 wrench 30 - 75 Nm
 Allen wrench 8 - 27 Nm



D

MAIN RELIEF VALVE DIRECT OPERATED
 (setting range from 25 to 250 bar - 362 to 3625 psi)

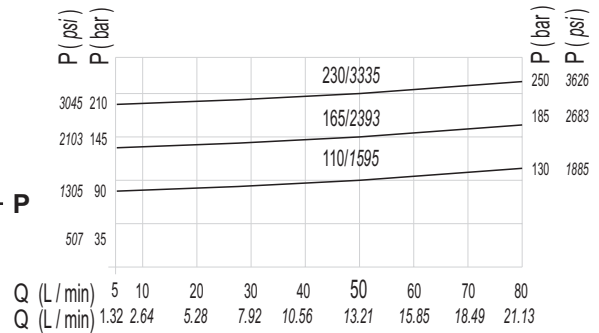
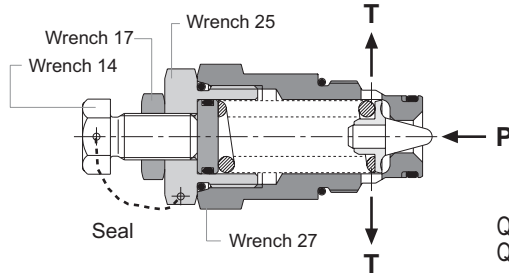
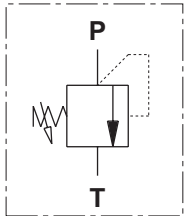

P

MAIN RELIEF VALVE PILOT OPERATED
 (setting range from 25 to 280 bar - 362 to 4061 psi) first spring
 (setting range from 100 to 400 bar - 1450 to 5800 psi) second spring

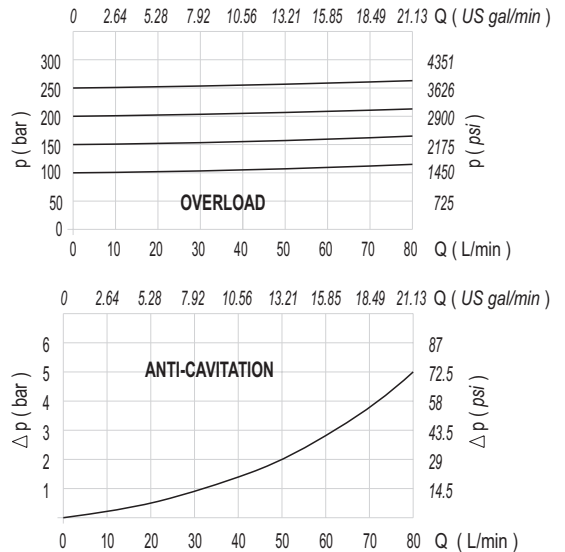
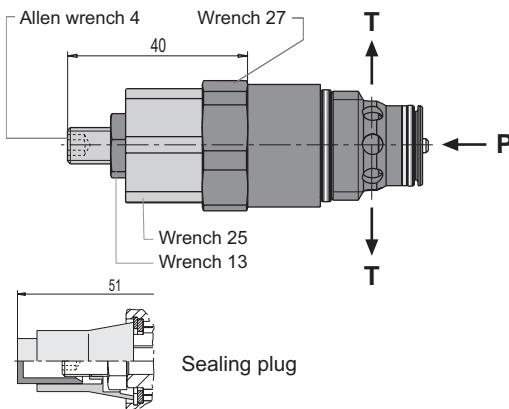
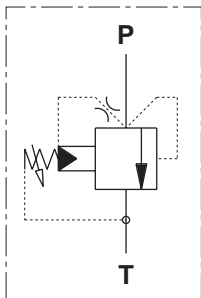

Both valves **D** and **P** are adjustable without oil leaking. Further more, both have a security device to avoid valve sticking

W

PLUG FOR MAIN RELIEF SEAT WITHOUT VALVE

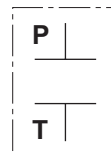
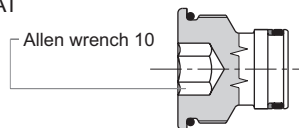

VENTING VALVES

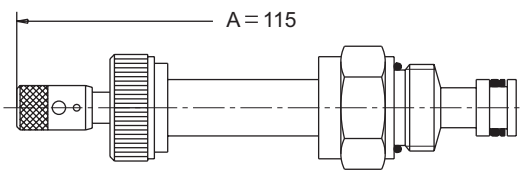
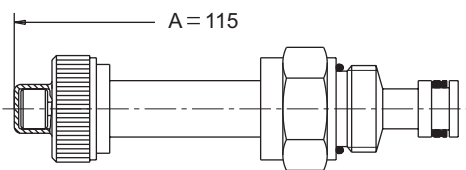
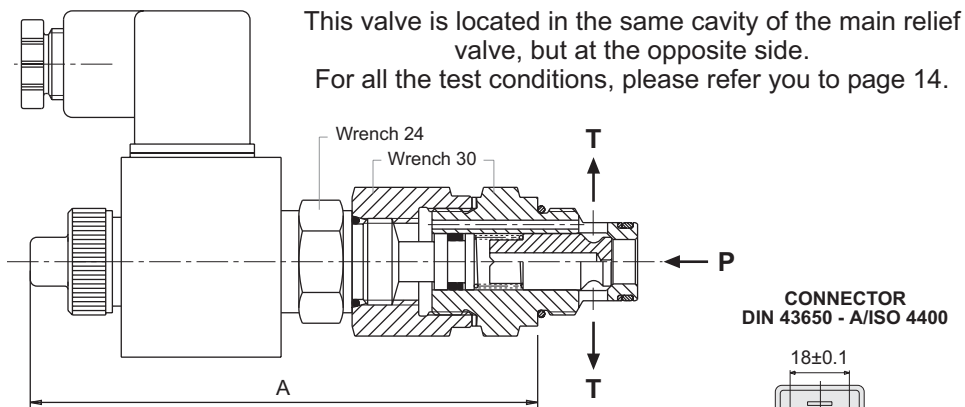

CONNECTOR
DIN 43650 - A/ISO 4400

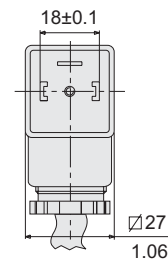

SPECIFICATIONS

- MAX PRESSURE IN "P"	350 bar
- MAX FLOW	75 l/min
- OIL LEAKAGE-max pressure-46cST	1 cm ³ /min
- AVAILABLE VOLTAGE	12 - 24 Vcc
- COIL RESISTANCE	12Vdc:8.7Ω - 24Vdc:33Ω
- COIL POWER	17 W
- PROTECTION INDEX WITH STANDARD CONNECTOR	IP 65

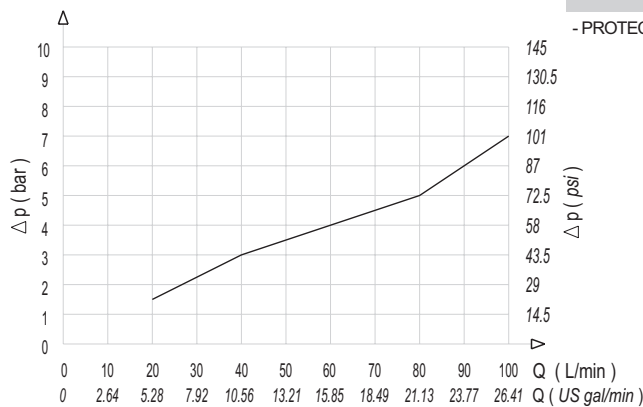

EV1

12 Vdc - Normally opened
Push override

EV2

24 Vdc - Normally opened
Push override

EV3

12 Vdc - Normally closed
Without override

EV4

24 Vdc - Normally closed
Without override

EV5

12 Vdc - Normally opened
Push and twist override

EV6

24 Vdc - Normally opened
Push and twist override

Normally opened

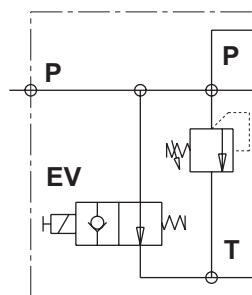

Normally closed

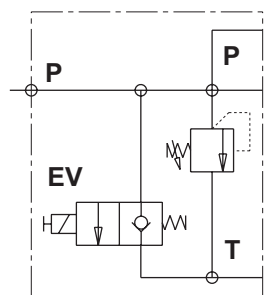

A available threads
M10 x 1 SAE 6

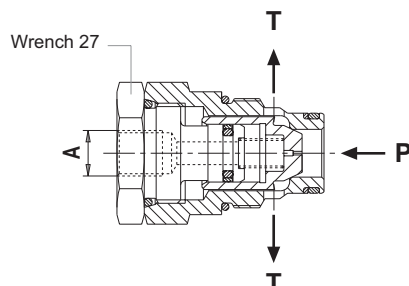

Normally opened

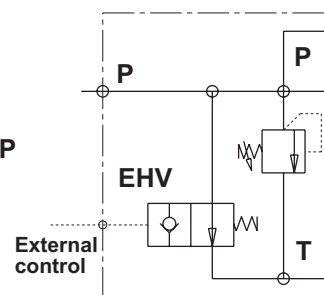

EHV

External piloted
venting valve

AUXILIARY VALVES



This picture shows the position of the auxiliary valves. For the tightening torque please see page 14.

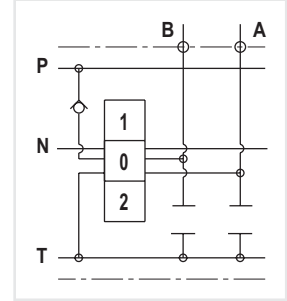

AR

AR - Not adjustable overload and anti-cavitation valve

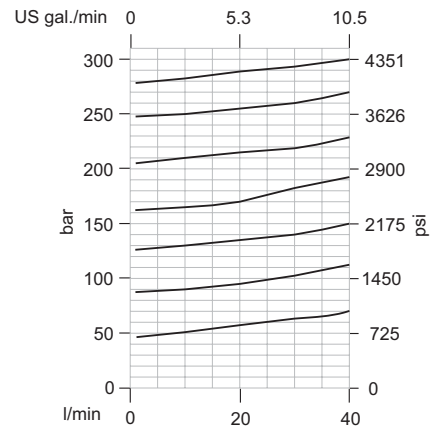
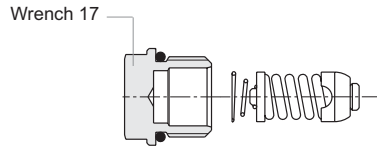

AVAILABLE SETTINGS

bar	25	32	40	50	63	80	100	125	140	160	175	190	210	230	250	280	315	350
psi	362	464	580	725	910	1160	1450	1810	2000	2300	2530	2715	3000	3300	3600	4000	4569	5076

VR

VR - Anti-cavitation valve

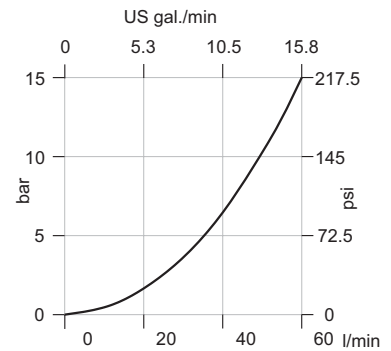
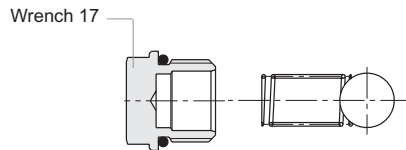
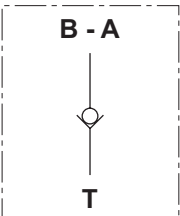

PR

PR - Plug for cavity

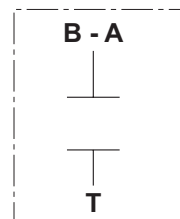
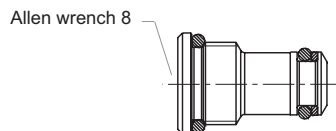

OTHER VALVES

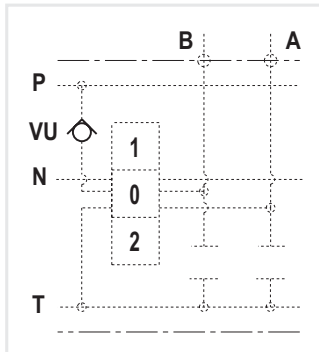

This is the load check valve VU which is built in every section between ports for the monoblock from 2 to 5 sections and you need not to specify in phase of ordering because it is part of the monoblock. This valve has in the VDM8 - 1 section, another position, as you can see in the drawing of page 9.

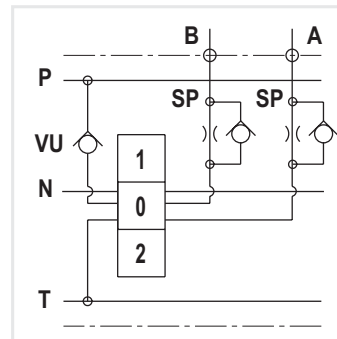
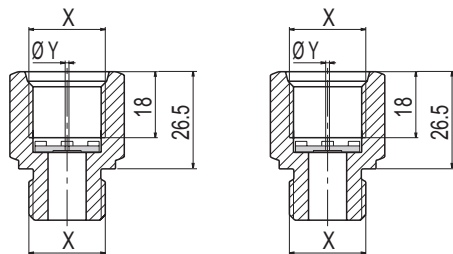

SP

Flow restrictor P → A/B

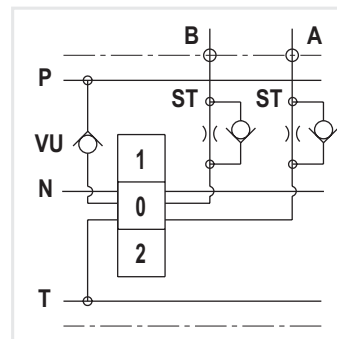
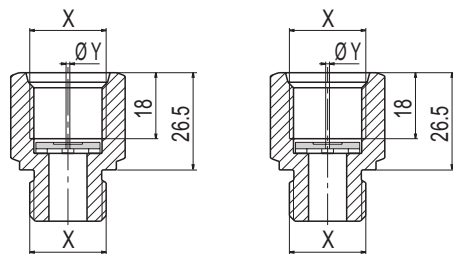

ST

Flow restrictor A/B → T

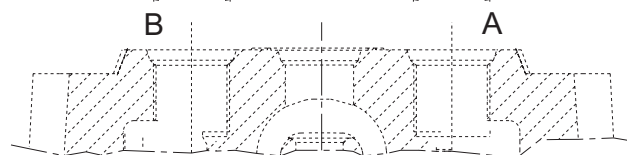

For tightening torque, please refer you to page 5.

X available threads			φ Y available measures					
*M22 x 1.5	SAE 10	G 1/2	φ 2	φ 2.5	φ 2.75	φ 3	φ 3.25	φ 4.5

*Available for quantity, please contact our sales dept.

SPOOL CONTROLS AND SPOOL POSITIONINGS

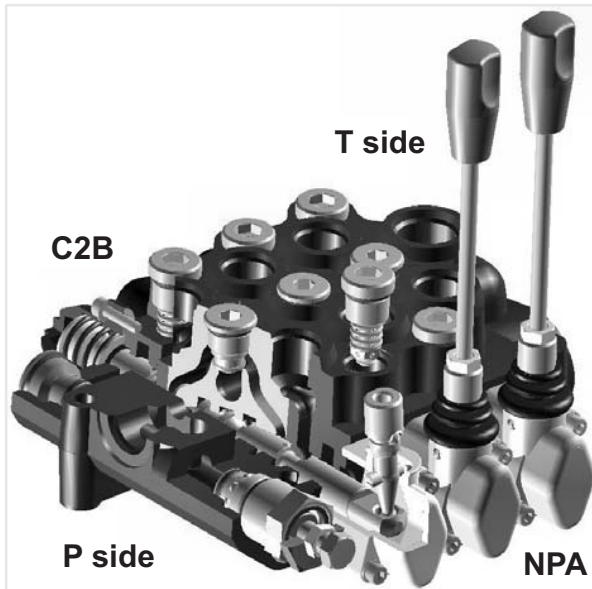

This picture shows the VDM8 assembled, in this case you have a manual control "NP" on A side and a spring return in neutral position "C2" on B side. In this case the manual control "NP" is used directly to have the spool movement, in other case, for example with electro-hydraulic control, there is only a safety lever. Considering that VDM8 is a simmetrical valve, all spool controls and positionings can be placed on both sides A or B. In case of hydraulic kick-out "G2 - G4 - G5" and with spools types 13 - 17 - 18, you can also decide from A or B side but after that this is the final position because with this type of control and spools the monoblock have a special machining.

In this and following pages you can find all spool controls and spool positionings, they are all assembled with socket hexagon head screw or in some case hexagon head screw: **M5 x 0.8 with tightening torque of 4.5 ± 0.5 Nm.**

The drw. here below show the reference to fix A and B side from the point of view of the operator.

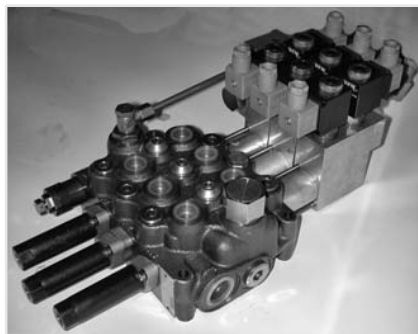

**VDM8 - 3 working sections
with electro-hydraulic controls
H1/H2 - H3/H4**

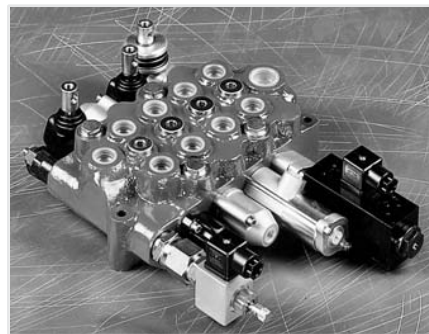

**VDM8 - assembling for exhibitions
with miscellaneous of controls
IP - NP - E7/E8 - LS - C2**

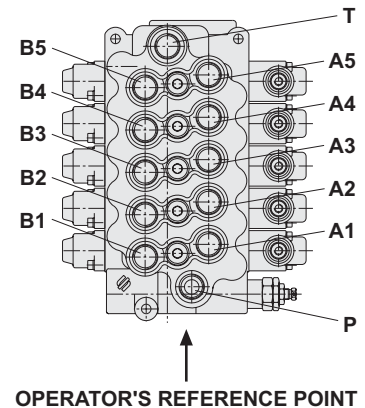

**VDM8 - 3 working sections
with pneumatic prop. control **PP** and
electro-pneumatic control **P1/P2****



**VDM8 - 5 working sections
with hydraulic prop. control **IP** and
hydraulic prop. control with float pos. **IF****

SPOOL CONTROLS

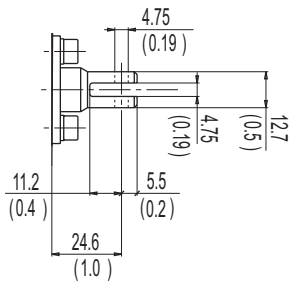

Female version
available for spools from 01 to 06
for the other spools please get in touch
with our sales dept.

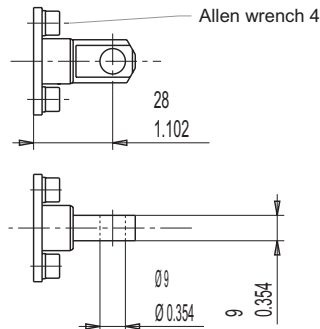

Male version

If you order SL we will supply the
male version, which is the
standard. For the female version
please specify it when ordering.

SL

Without lever box

- 1
- 0
- 2

This lever can be assembled turned of 180°

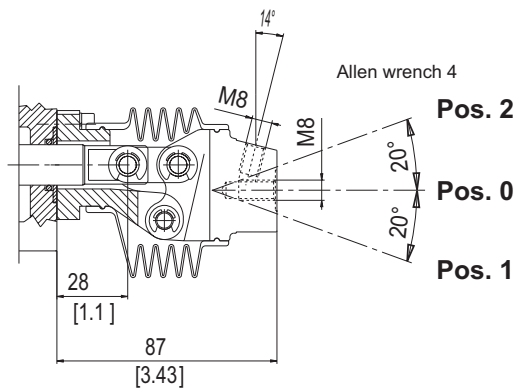

NL

Low effort
protected lever

- 1
- 0
- 2

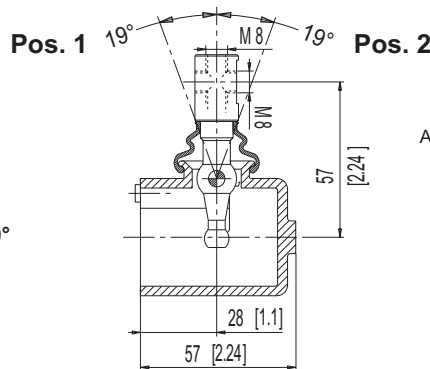

NP

Standard
protected lever

- 1
- 0
- 2

This lever can be assembled turned of 180°

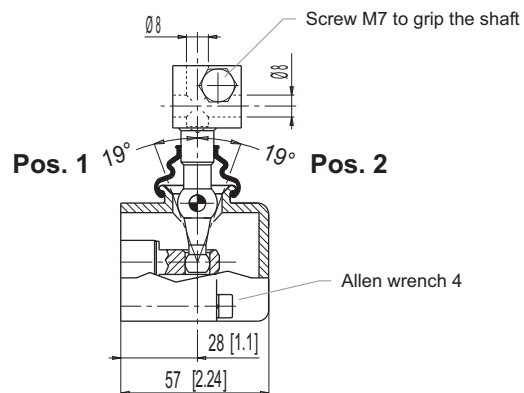

MP

Protected clamp lever

- 1
- 0
- 2

This lever can be assembled turned of 180°

SS

Lever with security locking in neutral pos.
Side shift to unlock



This lever with security locking in neutral pos.
has been created to avoid its accidental
movement caused by vibrations of the
application.

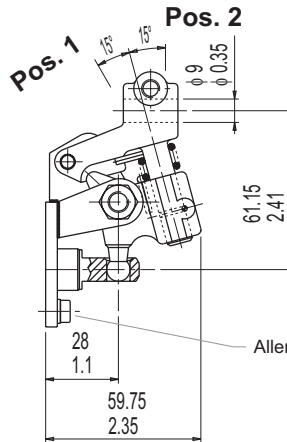

This lever can be assembled turned of 180°

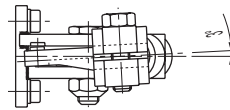

Necessary side shift to release the security locking

FL

Lever with security locking in neutral pos.
Pull the grip to unlock.



This lever with security locking in neutral has been
created to avoid its accidental movement
caused by vibrations of the application.
Before to put the lever in positions 1 and 2
you must release it by pulling it as per the arrows

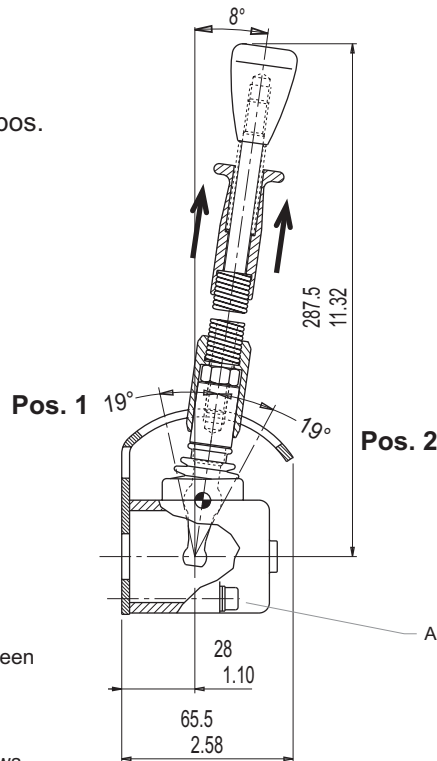

This lever can be assembled turned of 180°

L2

Cross lever for 2 spools
fulcrum on down-stream spool

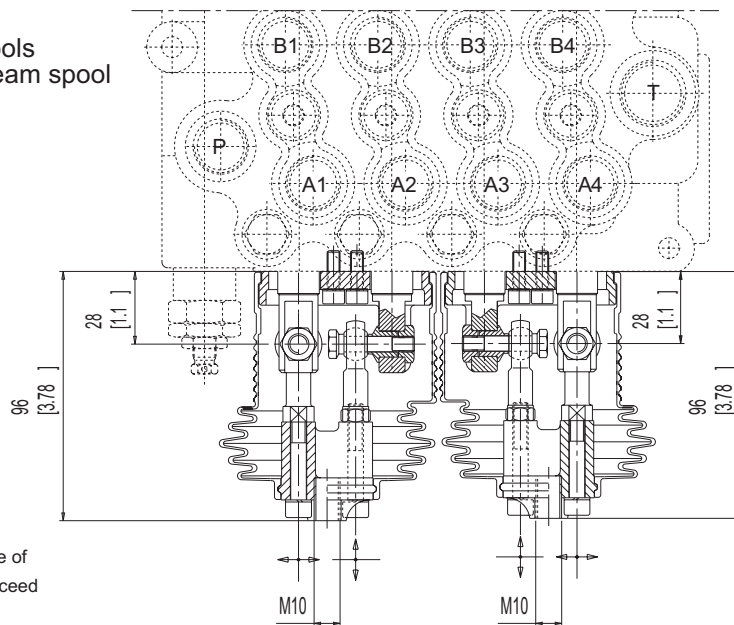
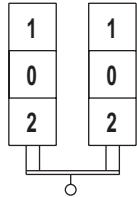

L1

Cross lever for 2 spools
fulcrum on up-stream spool

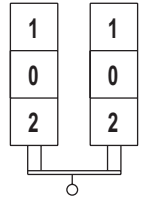

For VDM8 we suggest the use of L1* and L2* in order not to exceed the fixing plane dimension.

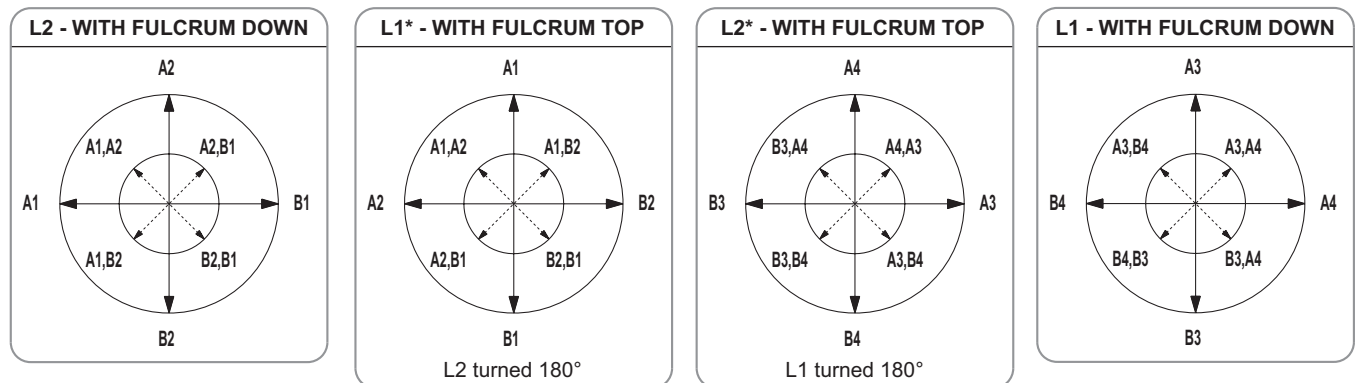

STANDARD SHAFTS

For different diameter and/or length, please get in touch with our sales dept.

Shaft with ergonomic knob
for cross lever L1/L2
R202 8996 0

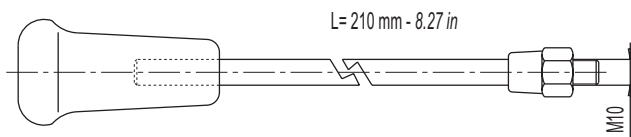

Shaft with threaded end
R202 9018 0

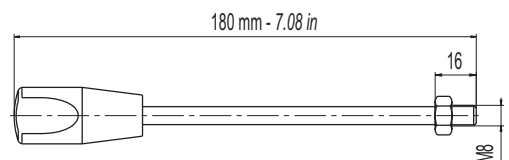

Shaft for clamp lever
R202 8839 0

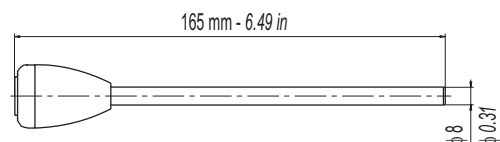

CR

Rotary control, available for 1 working section or two working section but one at the opposite side of the other.
This device is realized for marine applications, so all the material components are corrosion proofing.

This control uses special type spools, available types are: 01 - 02. Mountable on both side (A or B).

Device with cam
and adjustable friction
detent + rotary lever

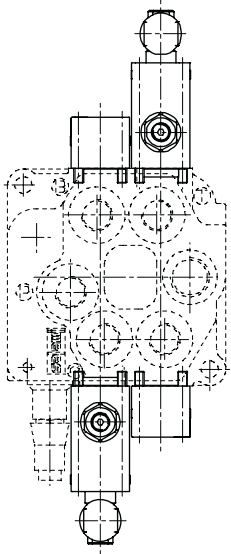
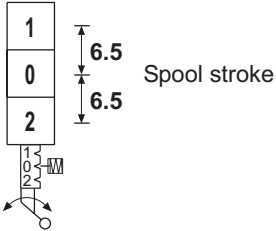

The two sections drawing shows a VDM6 valve, but it is only an example to explain the assembling feature.

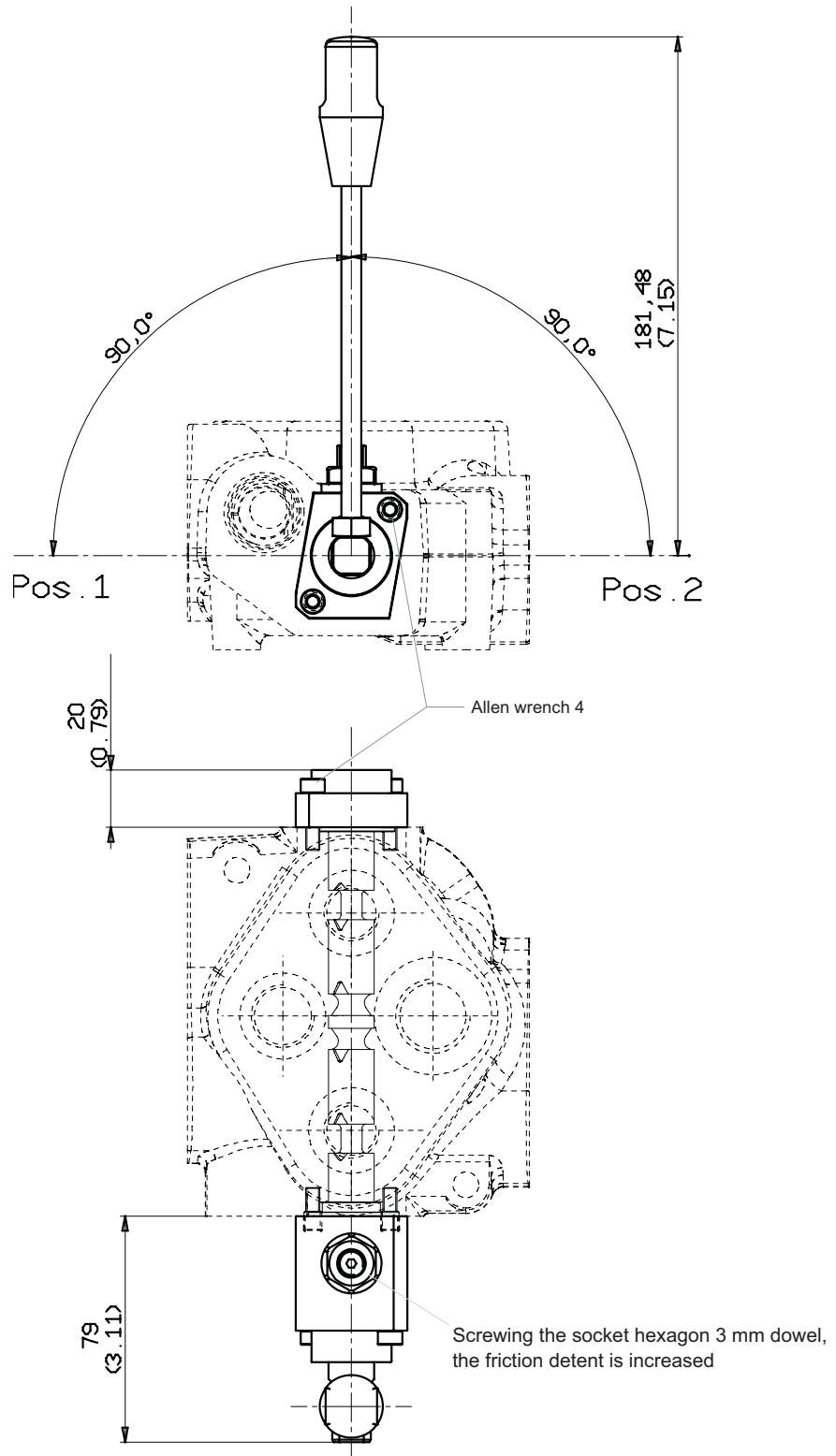

D1

Devices for cable remote control for both the ends of spool.
For more details about cables, please consult our catalogue
cable remote controls.

TC

End spool with threaded hole M7
Positionings side

End spool with hole ϕ 9 mm.
Controls side

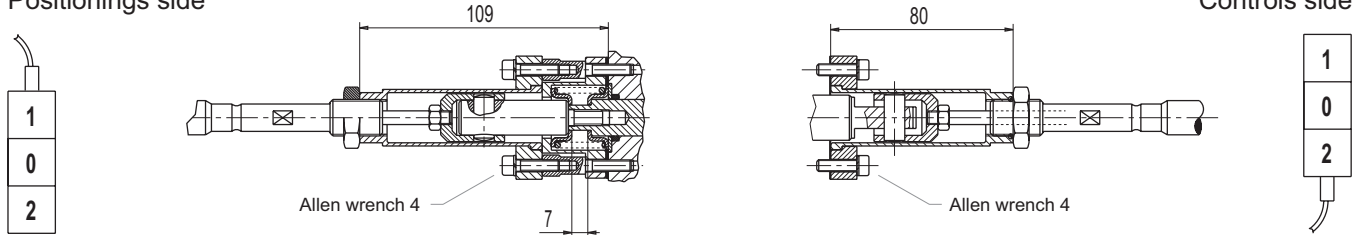

E1

Working conditions for this control:

Flows up to 70 l/min - 18.5 US gpm
Pressure up to 240 bar - 3500 psi

SL

Electric push-pull control 3 positions
12 Vdc

Without lever for electric control
with override device

The stroke for this control is of 5 mm,
for this reason the spools are different of standard.

The available spools are from 01 to 06.

E2

Electric push-pull control 3 positions
24 Vdc

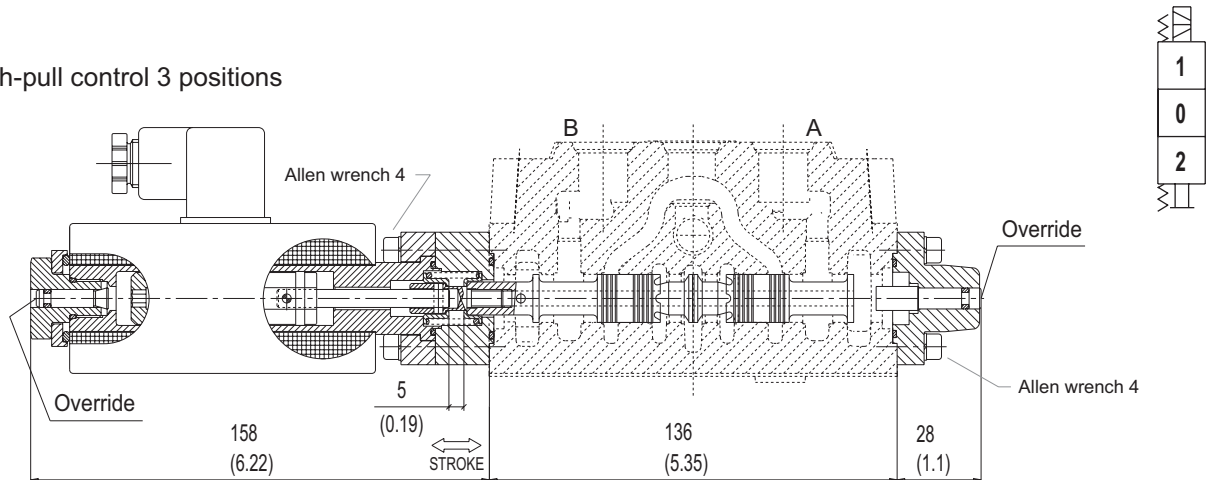

ELECTRICAL DATA

PUSH - PULL SOLENOID

- VOLTAGE: 12Vdc OR 24Vdc
- COIL POWER: 60 Watt at 20°C
- PROTECTION INDEX WITH CONNECTOR: IP 65
- HEAVY DUTY 70%

ES

Emergency lever for electric push-pull control

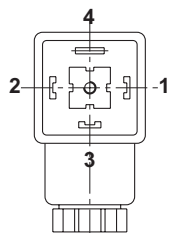

CONNECTOR
DIN 43650 - A/ISO 4400

ELECTRIC CONNECTIONS SCHEME

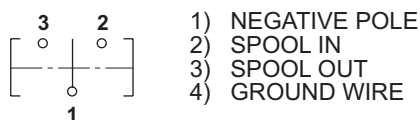

To avoid an excessive wear of the contacts, depending on the sparking of these parts, we suggest a suitable protection (for example diodes)

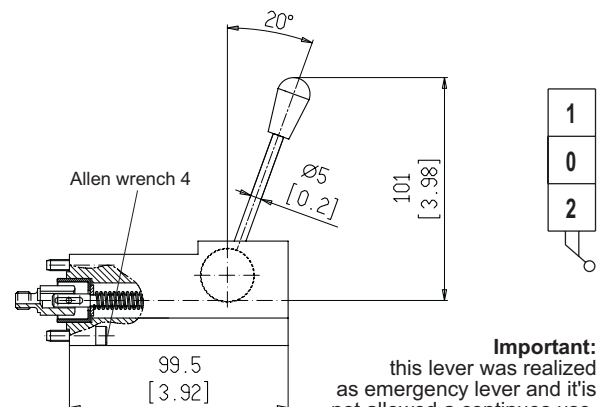

Important:
this lever was realized
as emergency lever and it's
not allowed a continuous use.

IP

Hydraulic proportional control

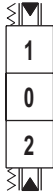

Important:
when you order please specify top or side ports

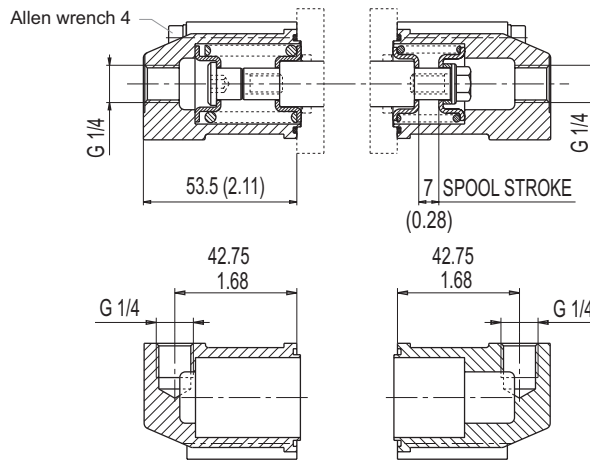

**Salami hydraulic
2 axis joystick**

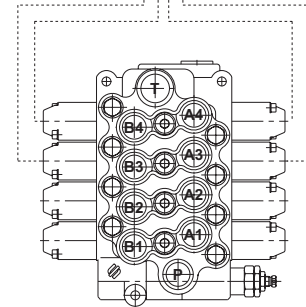
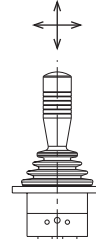

For more information please consult our catalogue
SHRC hydraulic remote controls.

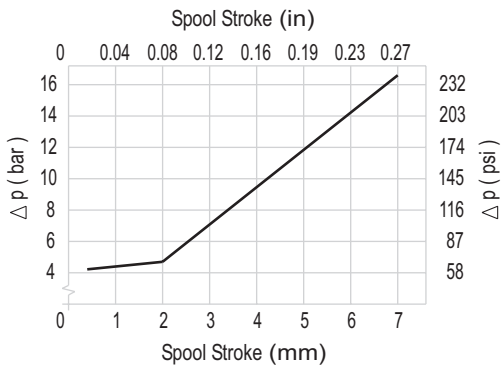

IF

Hydraulic proportional control
with third float position (spool in)

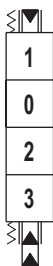

XA, XB, XF PORTS : G 1/4

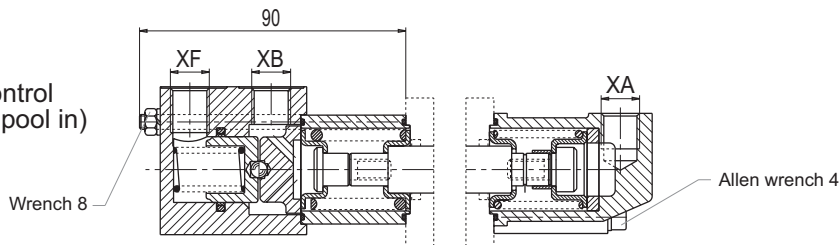

OPERATING SCHEME

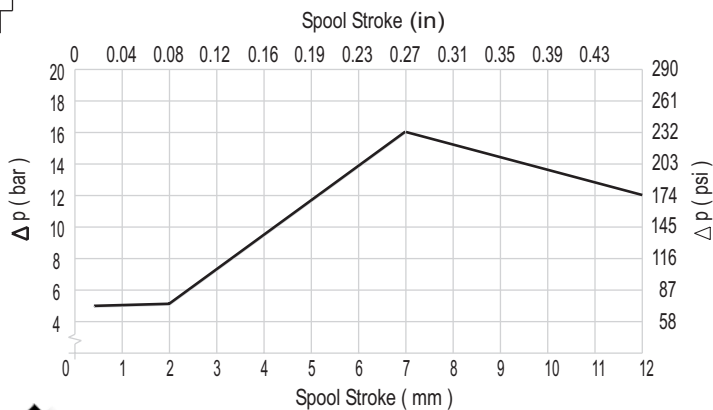
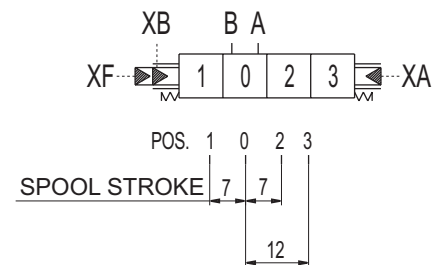

- XA, XB, XF → T ⇨ POS. 0
- Pressure → XB ⇨ POS. 1
- Pressure → XA, XF ⇨ POS. 2
- Pressure → XA ⇨ POS. 3

DIRECTIONAL CONTROL VALVE MONOBLOCK TYPE

VDM8

Thought for all truck hydraulic applications

PP/P0

Pneumatic proportional/on-off control

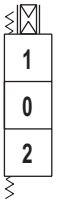
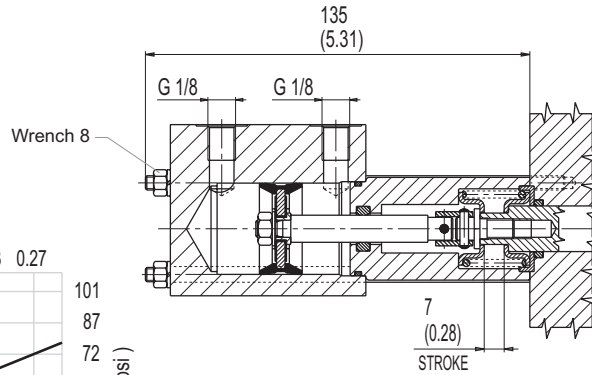
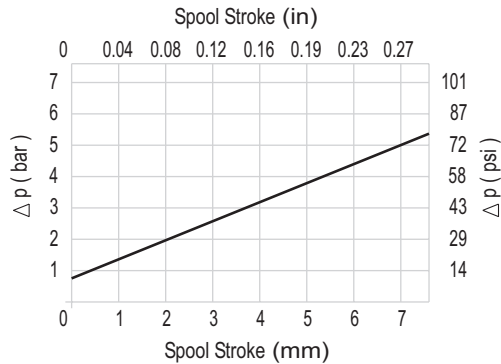

Pneumatic proportional/on-off control
This control is at the same time proportional and on-off type, it depends if you use a pneumatic remote control proportional type (with the characteristic curve of diagram), or on-off type.



ELECTRICAL DATA

- VOLTAGE: 12Vdc OR 24Vdc
- COIL POWER: 6 Watt at 20°C
- PROTECTION INDEX WITH CONNECTOR: IP 65

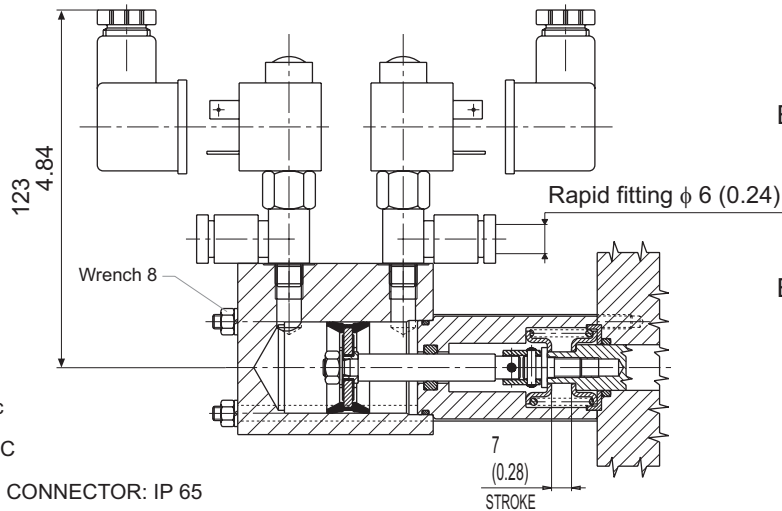

P1

Electro-pneumatic on-off control - 12 Vdc

P2

Electro-pneumatic on-off control - 24 Vdc



Starting from PP/PO adding the electro-valves you get P1 or P2

OPERATING SCHEME

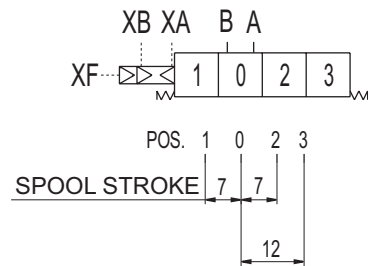

- XA, XB, XF → T → POS. 0
- Pressure → XB → POS. 1
- Pressure → XA, XF → POS. 2
- Pressure → XA → POS. 3

XA, XB, XF PORTS : G 1/4

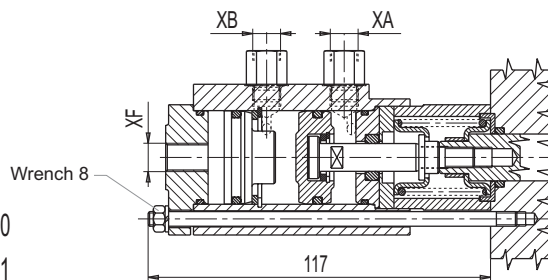

Pneumatic on-off control with third float position (spool in)



For electro-pneumatic control with third float position, please get in touch with our sales dept.

Preliminary specifications about electro-hydraulic controls

Before to introduce electro-hydraulic single modules it is necessary to specify the adding hydraulic components necessary for the right functioning of it. As you can see in the drawing and hydraulic scheme it needs a pressure reducing valve "PRV" at the inlet of piloting circuit that reduce the pressure of "P" line at the max value of 25 bar (363 psi), a back pressure "CPV" on neutral line that assure a min. pressure of 8 bar (116 psi) and some accessories as fittings, pipe and filter. The pressure reduction at the piloting circuit inlet and the minimum value of

neutral line can be obtained also with external standard valves made by valve manufacturer, for this reason Salami electro-hydraulic controls can be supplied without "PRV" and "CPV".

In this case is necessary to specify it in phase of order.

Our standard supply has the "Tp" port opened, we recommend to connect it directly to tank because a counter-pressure could be cause of malfunction.

With reference to page 9, "INLET AND OUTLET TYPES", the outlet U8 is shown in the hydraulic scheme here below, remember that with a special plug instead of "CPV" valve you can change U8 in a power beyond outlet type "U5".

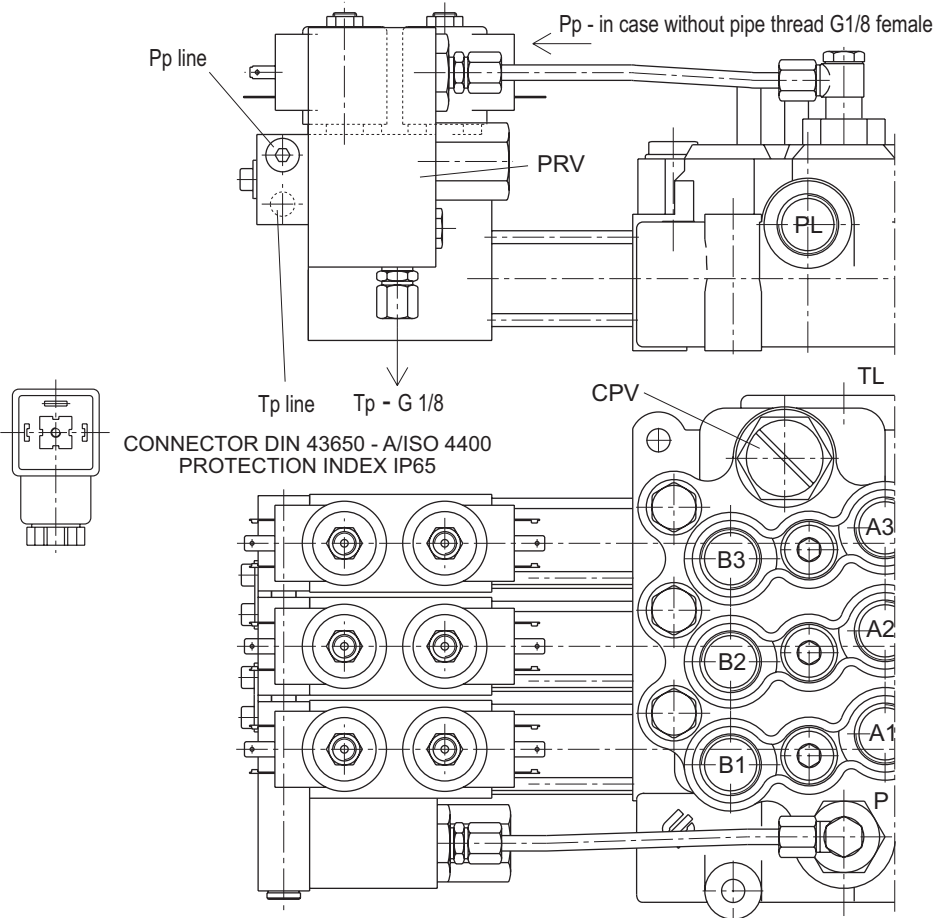

INDEX

PRV - pressure reducing valve

CPV - counter pressure valve

Pp - pressure piloting line

Tp - tank piloting line

PL - P port

TL - T port

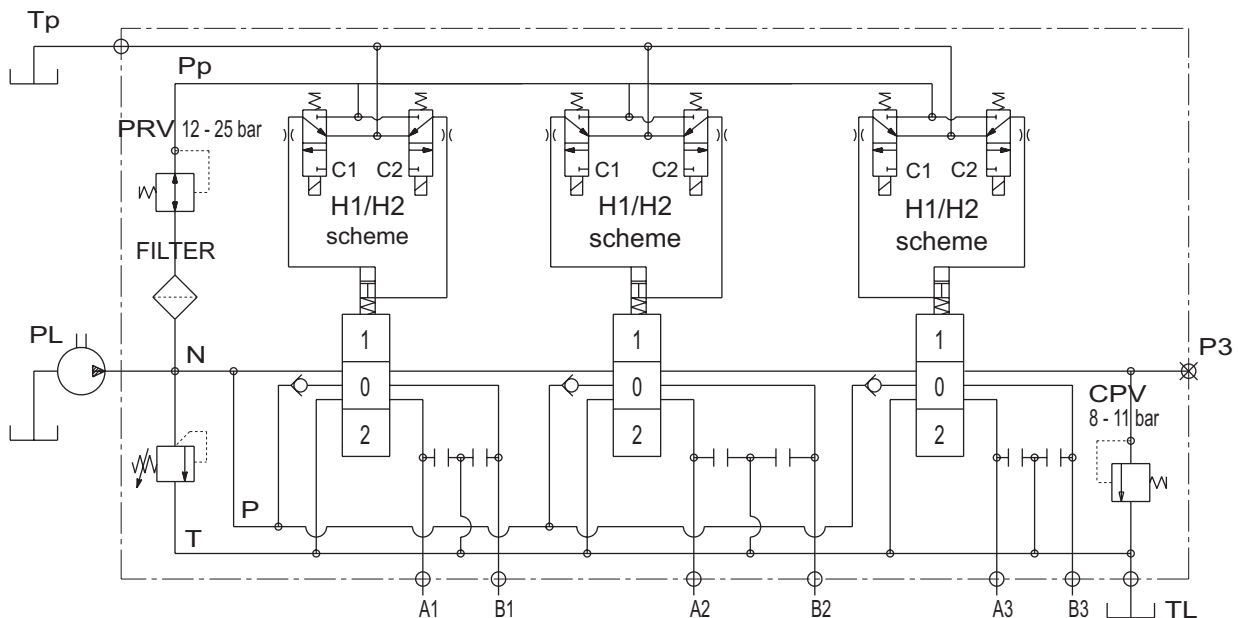

DIRECTIONAL CONTROL VALVE MONOBLOCK TYPE

VDM8

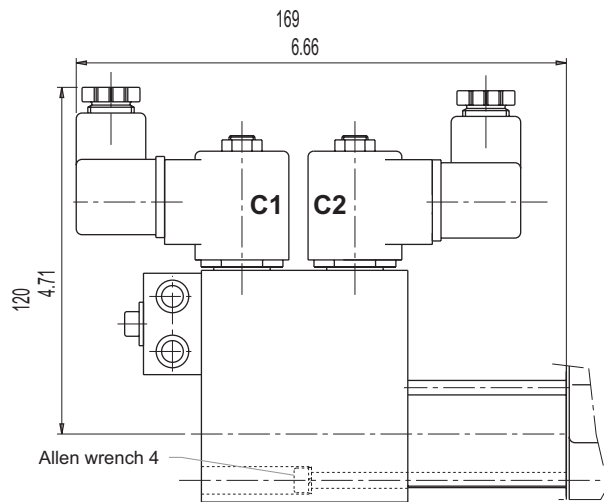

OPERATING INSTRUCTIONS
please see the hydraulic circuit
of page before

- C1 - C2** coils de-energized \Rightarrow POS. 0
- C1** coil energized \Rightarrow POS. 1
- C2** coil energized \Rightarrow POS. 2

TECHNICAL DATA

- MAX PRESSURE IN "P" 30 bar
- MAX FLOW 2 l/min
- AVAILABLE VOLTAGE 12 - 24 Vcc
- COIL RESISTANCE 12Vdc:7.2 Ω - 24Vdc:41.5 Ω
- POWER 14 W (20°C)

H1

ON-OFF
electro-hydraulic control
12 Vdc

H2

ON-OFF
electro-hydraulic control
24 Vdc

SPOOL POSITIONINGS

C2

Spring centered to neutral position

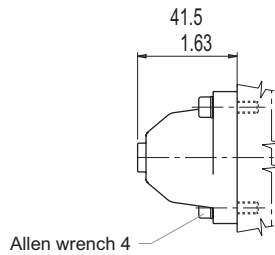
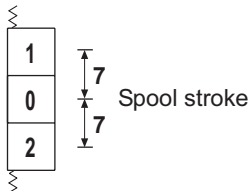

C6

Two positions (neutral/pos. 1)
with spring return in neutral

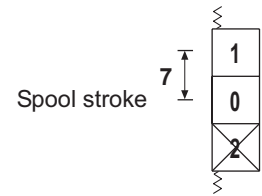

C5

Two positions (neutral/pos. 2)
with spring return in neutral

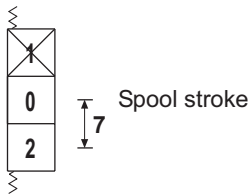

C3

Spring centered to neutral
(pivot threaded male
for remote control)

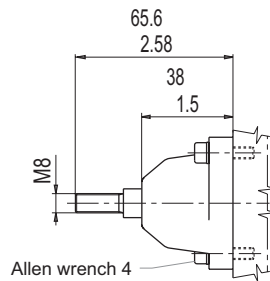
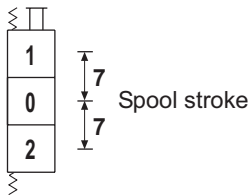

C4

Spring centered to neutral
(pivot threaded female
for remote control)

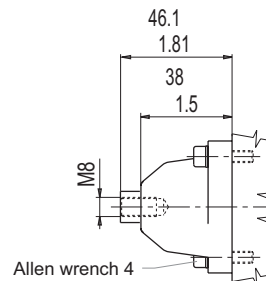
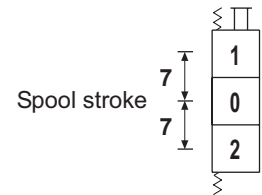

C7

Two positions (pos. 1/pos. 2)
with spring return in pos. 1

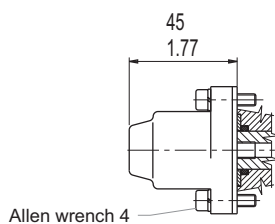
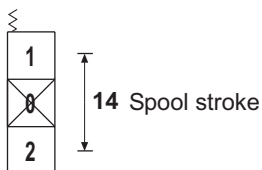

C8

Two positions (pos1/pos. 2)
with spring return in pos. 2

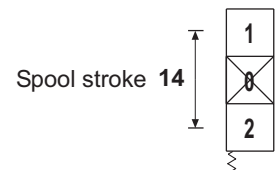

R2

Detent on pos. 1/pos. 2
with spring return in neutral

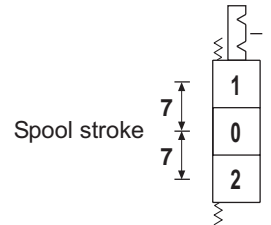

R5

Detent on pos. 2
with spring return in neutral

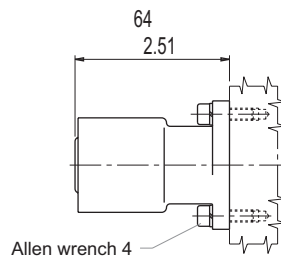
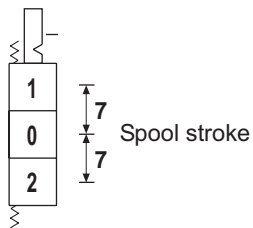

R4

Detent on pos. 1
with spring return in neutral

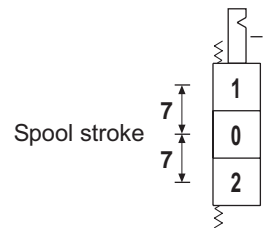

R6

Two positions with detent on pos. 2
with spring return in neutral

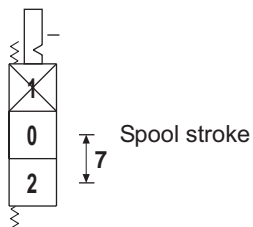

R7

Two positions with detent on pos. 1
with spring return in neutral

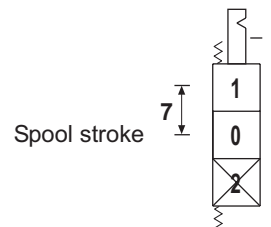

CO

Detent on each intermediate positions

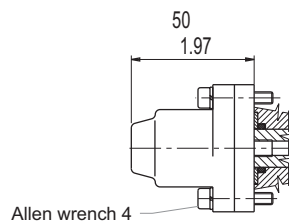
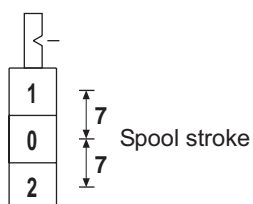

R9

Detent on pos. 1/pos. 2
and neutral position

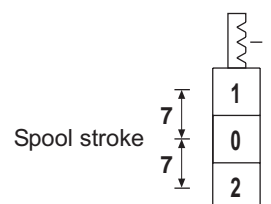

F1

Detent on pos. 3
with spring return in neutral

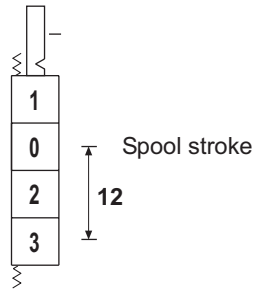

F2

Detent on pos. 1/pos. 2/pos. 3
with spring return in neutral

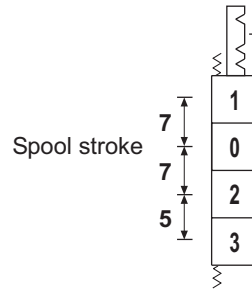

F3

Detent on pos. 1/pos. 3
with spring return in neutral

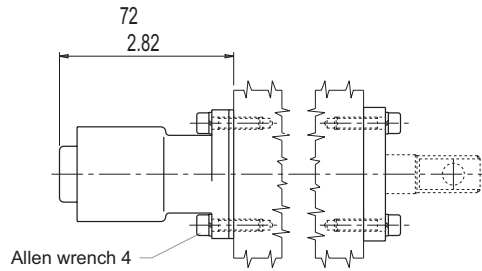
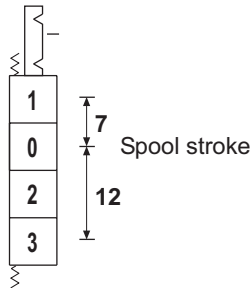

F4

Detent on pos. 2/pos. 3
with spring return in neutral

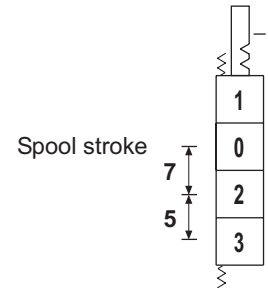

F5

Detent on pos. 3
with spring return in neutral

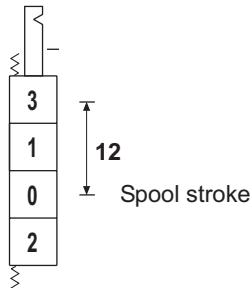

F6

Detent on pos. 1/pos. 3
with spring return in neutral

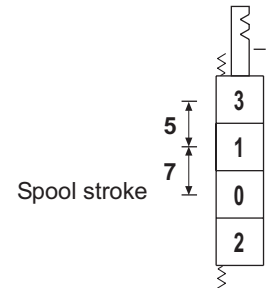

F7

Detent on pos. 2/pos. 3
with spring return in neutral

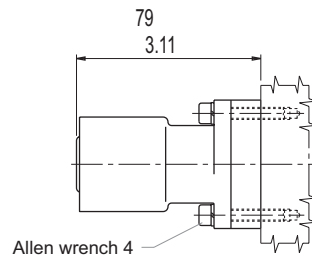
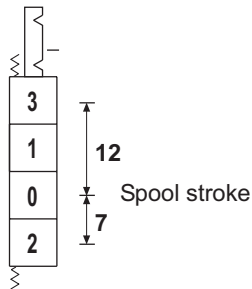

F8

Detent on pos. 1/pos. 2/pos. 3
with spring return in neutral

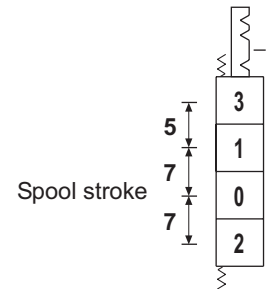

DIRECTIONAL CONTROL VALVE MONOBLOCK TYPE

VDM8

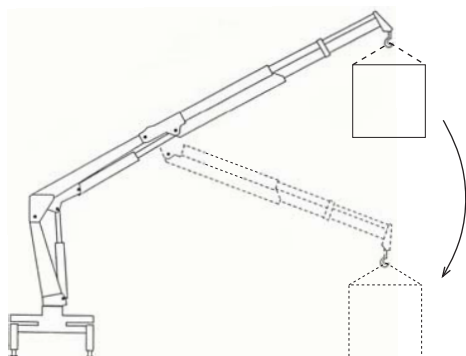

For manufacturers using load and overturning torque limiting device for hydraulically operated cranes, Salami VDM8 valve is available with some devices that allow the manufacturer to supply a pressure signal inside itself. This pressure signal, acting on the area of a piston of 18 mm (0.71 inc.) diameter, reacts to the force of the manual control bringing back the spool at the position 0.

These devices are only available in combination with manual control.

D9

Device for spool positioning in 0 from the positions 1 and 2 by an external pressure signal. For tie-rod connection.

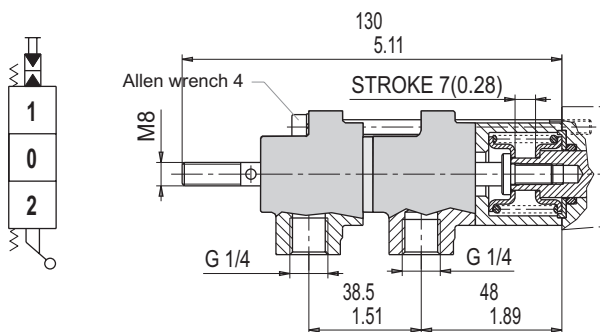

Device for spool positioning in 0 from the positions 1 and 2 by an external pressure signal.

M3

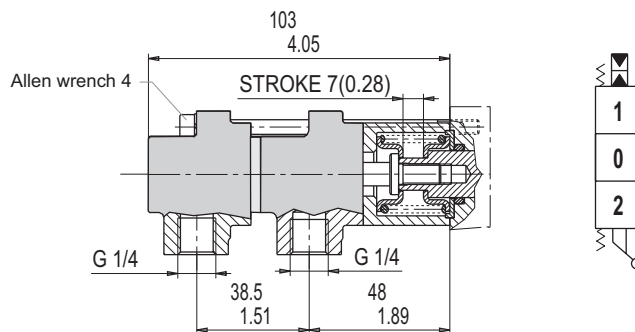

D8

Device for spool positioning in 0 from the position 1 by an external pressure signal. For tie-rod connection.

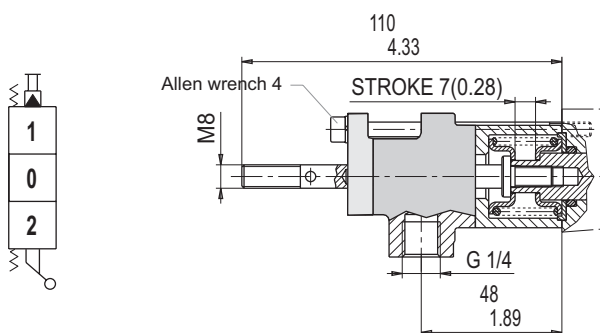

Device for spool positioning in 0 from the position 1 by an external pressure signal.

M1

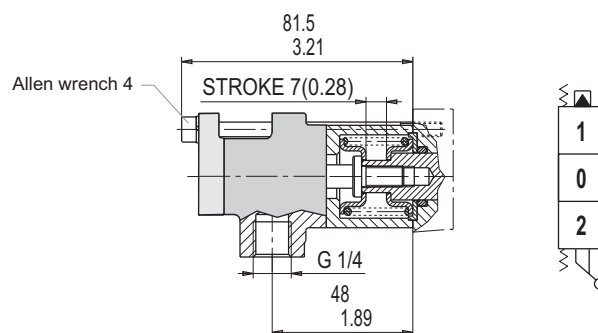

D7

Device for spool positioning in 0 from the position 2 by an external pressure signal. For tie-rod connection.

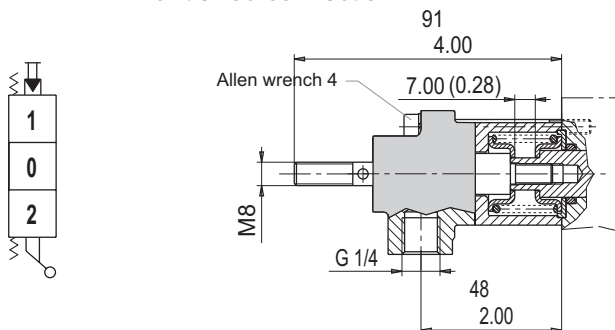

Device for spool positioning in 0 from the position 2 by an external pressure signal.

M2

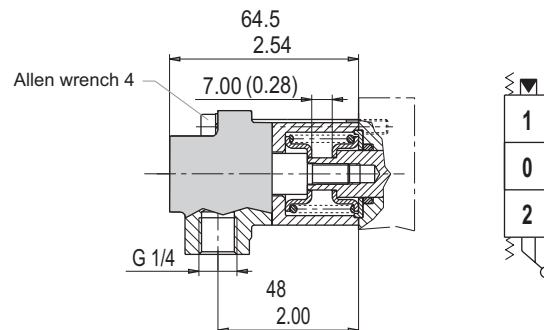

CE

Pre-arrangement for electrical device

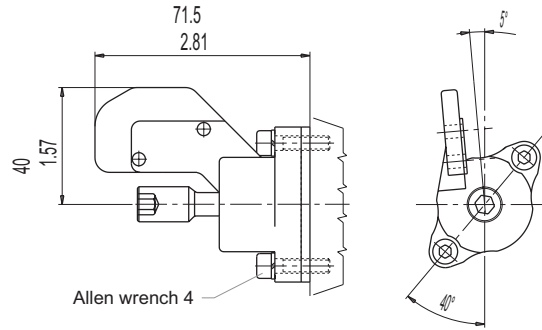
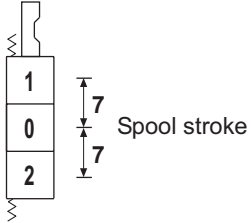

CM

MICROSWITCH TYPE: SAIA - BURGESS XGK - 88

For more information please get in touch with our sales dept.

Spool positioning with microswitch to start an electric motor (available also for single acting spools)

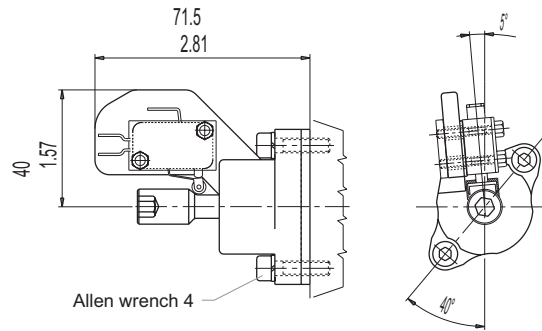
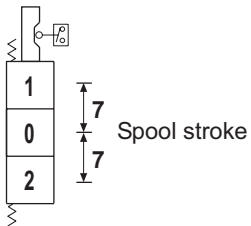

PROTECTION INDEX
IP65

CW

Spool positioning with waterproof microswitch to start an electric motor (available also for single acting spools)

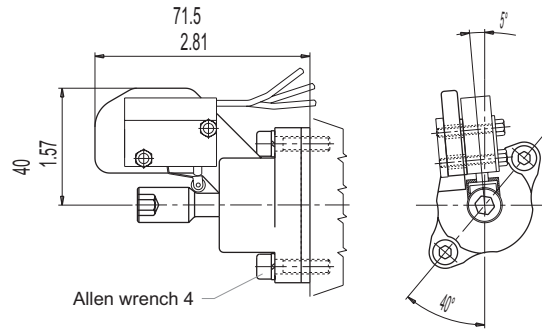
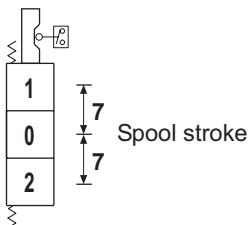

PROTECTION INDEX
IP67

CD

Spool positioning with double microswitch (available also for single acting spools)

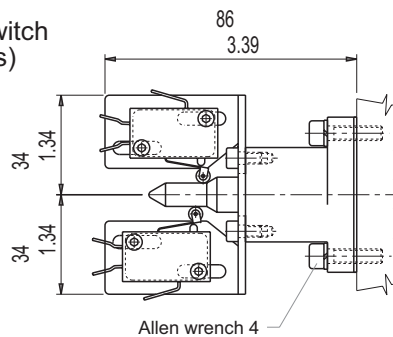
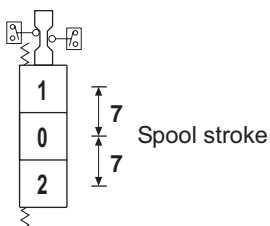

PROTECTION INDEX
IP65

DIRECTIONAL CONTROL VALVE MONOBLOCK TYPE

VDM8

PM

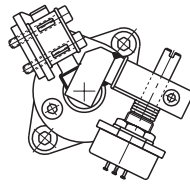
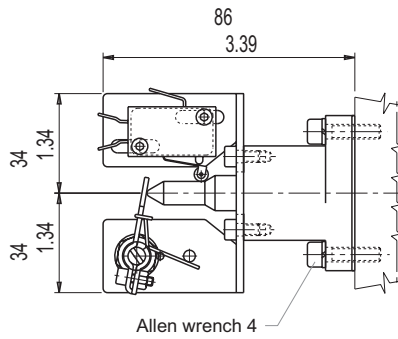

Spool positioning with microswitch to start an electric motor and potentiometer to run up speed motor (available also for single acting spools)

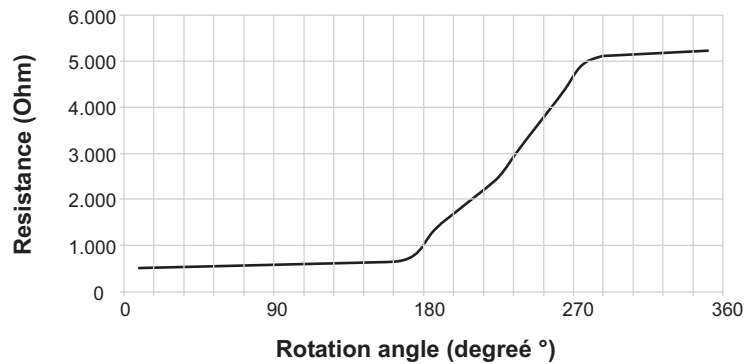
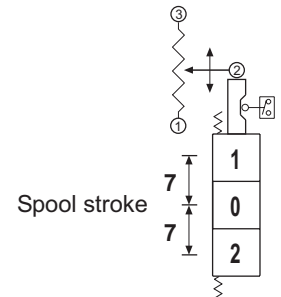

IMPORTANT:

When you order, please specify the setting pressure of the device.
With this type of spool positioning a special machining of the body is required.

G2

Detent on pos. 1/pos. 2 with hydraulic kick-out

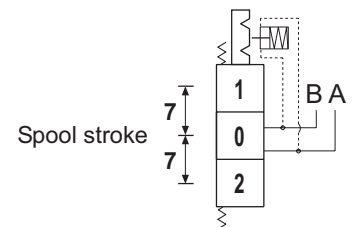

G5

Detent on pos. 2 with hydraulic kick-out

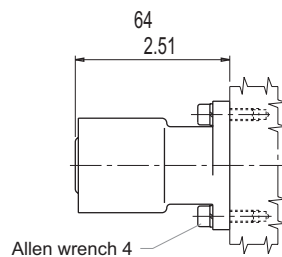
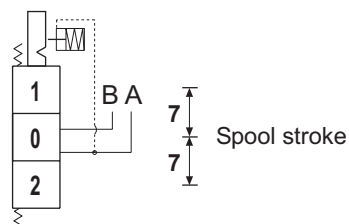

G4

Detent on pos. 1 with hydraulic kick-out

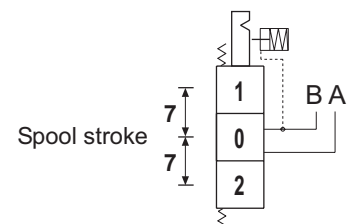

How to order/VDM8

DIRECTIONAL CONTROL VALVE MONOBLOCK TYPE

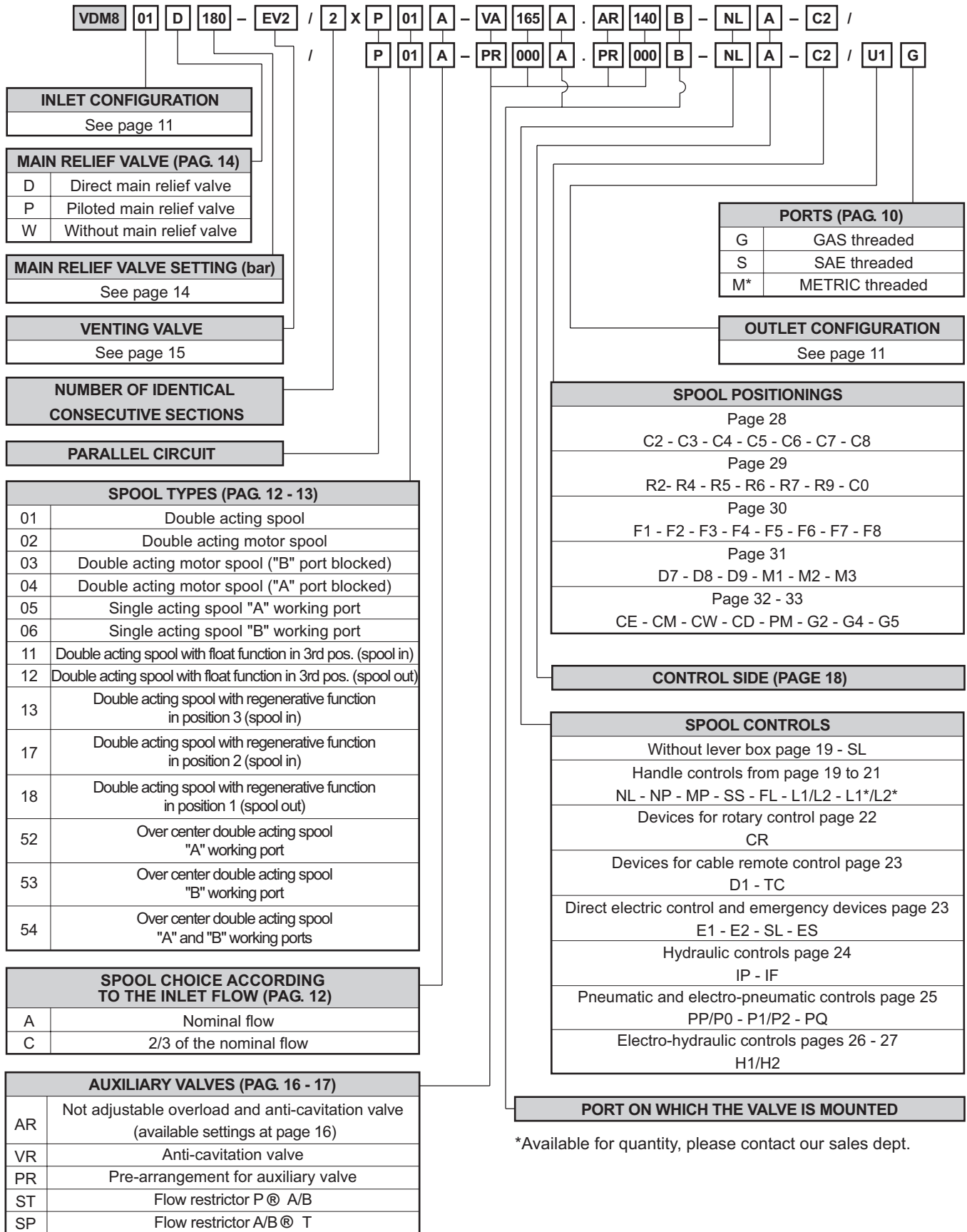

*Available for quantity, please contact our sales dept.

DESCRIPTION OF THE NEW PRODUCT IDENTIFICATION LABEL

Based on the firm certification ISO 9001 - UNI EN 29001, section 4.8 (identification and traceability of the product), we have adopted a new identification label starting from the 1st march 1995. Pls, see following example:

A			
B			
C		D	
E	salami	F	G

- A = Product short description (eg. VD8A/FDD/U4G).**
- B = Customer part number.**
- C = Salami part number (eg. 6235 0025 0).**
- D = Production code (for Salami management)**
- E = Rotation sense (only for pumps).**
- F = Production date (see data sheet here below)**
- G = Progressive number of assembling.**

Only for pumps 2PB and 2PZ (except triple 2PB) the identification product is marked on the top of the pump body as shown here below:

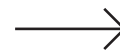

SALAMI 09/02
MADE IN ITALY 4010998
612271211 nr. 13
2PB 19S B25 B5

- Product short description. _____
- Salami part number and progressive number of assembling. _____
- Production code (for Salami management). _____
- Month and year of made: maybe in the future you can find this type of production date in the label beside too. _____
- Rotation sense. _____

ASSEMBLED	1997	1998	1999	2000	2001	2002	2003	2004	2005	2006	2007	2008	2009	2010	2011	2012
JANUARY	7A	8M	9M	0M	1M	2M	3M	4M	5M	6M	7M	08M	09M	10M	11M	12M
FEBRUARY	7B	8N	9N	0N	1N	2N	3N	4N	5N	6N	7N	08N	09N	10N	11N	12N
MARCH	7C	8P	9P	0P	1P	2P	3P	4P	5P	6P	7P	08P	09P	10P	11P	12P
APRIL	7D	8Q	9Q	0Q	1Q	2Q	3Q	4Q	5Q	6Q	7Q	08Q	09Q	10Q	11Q	12Q
MAY	7E	8R	9R	0R	1R	2R	3R	4R	5R	6R	7R	08R	09R	10R	11R	12R
JUNE	7F	8S	9S	0S	1S	2S	3S	4S	5S	6S	7S	08S	09S	10S	11S	12S
JULY	7G	8T	9T	0T	1T	2T	3T	4T	5T	6T	7T	08T	09T	10T	11T	12T
AUGUST	7H	8U	9U	0U	1U	2U	3U	4U	5U	6U	7U	08U	09U	10U	11U	12U
SEPTEMBER	7I	8V	9V	0V	1V	2V	3V	4V	5V	6V	7V	08V	09V	10V	11V	12V
OCTOBER	7J	8Z	9Z	0Z	1Z	2Z	3Z	4Z	5Z	6Z	7Z	08Z	09Z	10Z	11Z	12Z
NOVEMBER	7K	8X	9X	0X	1X	2X	3X	4X	5X	6X	7X	08X	09X	10X	11X	12X
DECEMBER	7L	8Y	9Y	0Y	1Y	2Y	3Y	4Y	5Y	6Y	7Y	08Y	09Y	10Y	11Y	12Y

WARRANTY

- We warrant products sold by us to be free from defects in material and workmanship.
- Our sole obligation to buyer under this warranty is the repair or replacement, at our option, of any products or parts thereof which, under normal use and proper maintenance, have proven defective in material or workmanship, this warranty does not cover ordinary wear and tear, abuse, misuse, averloading, alteration.
- No claims under this warranty will be valid unless buyer notifies SALAMI in writing within a reasonable time of the buyer's discovery of such defects, but in no event later than twelve (12) months from date of shipment to buyer.
- Our obligation under this warranty shall not include any transportation charges or cost of installation, replacement, field repair, or other charges related to returning products to us; or any liability for direct, indirect or consequential damage or delay. If requested by us, products or parts for which a warranty claim is made are to be returned transportation prepaid to our factory. The risk of loss of any products or parts thereof returned to SALAMI will be on buyer.
- No employee or representative is authorized to change any warranty in any way or grant any other warranty unless such change is made in writing and signed by an officer of SALAMI.



SALAMI spa
via Emilia Ovest 1006
41100 Modena Italy
telefono +39-059-387411
telefax +39-059-387500
export@salami.it - www.salami.it



SALAMI ITALIA srl
strada Pelosa 183
S. Pietro in Trigogna VI Italy
telefono +39-0444-240080
telefax +39-0444-240204
salami.italia@salami.it



SALAMI ESPAÑA
Poligono Industrial Armenteres
C/Primer de Maig, 18, Nave 4
08980 San Feliu de Llobregat
Barcelona
telefono +34-93-6327288
telefax +34-93-6667826
info@salamispain.com



SALAMI FRANCE
22, rue Louis Saillant
69120 Vaulx en Velin
Lyon
telefono +33-04-78809941
telefax +33-04-78803669
e.pasian@wanadoo.fr



149 S0. Chenango St. Ext.,
GREEN, NY 13778
Tel.: +1-607-6565702
Fax.: +1-607-6565704
info@salamihydraulics.com