

# MONOBLOCK VALVE

## VDM6

Technical catalogue

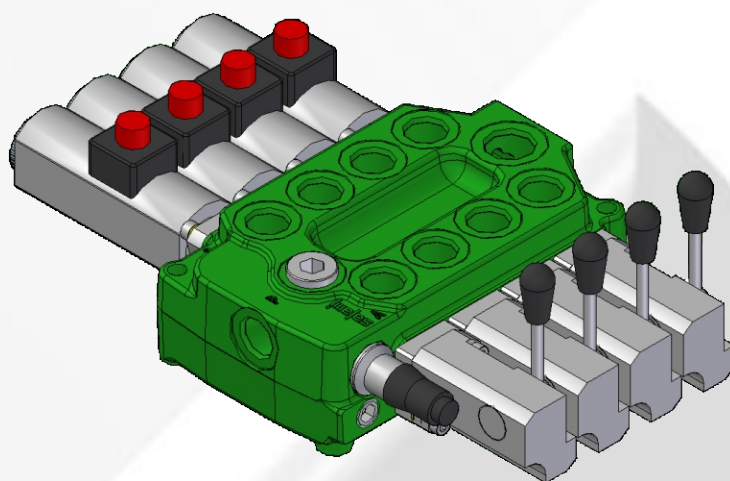

E0.02.0911.02.02

COMPANY  
WITH QUALITY SYSTEM  
CERTIFIED BY DNV  
=ISO 9001/2000=

**sajami** ™



## Page 1 - GENERAL INDEX

Page 2 - General features

Page 3 - Technical data - Working conditions

Page 4 - Operating principle

Page 5 - Hydraulic fluids - Installation - Filtration - Pipes

Page 6 - Performance data - Metering curves - Valve working limit

Page 7 - Performance data - Pressure drop "P" to "T" - Pressure drop "P" to "A/B" and "A/B" to "T"

Page 8 - Dimensions from 2 to 5 sections monoblock

Page 9 - Dimension for 1 section monoblock

Page 10 - Ports

Page 11 - Inlet and outlet types

Page 12 - Working sections (hydraulic circuits)

Page 13 - Notes

Page 14 - 15 - Circuit and spool types

Page 16 - Main relief valves

Page 17 - Venting valves

Pages 18 - 19 - Auxiliary valves

Page 20 - Spool controls and spool positionings

Page 21 - Spool controls - SL- NL - MP

Page 22 - Spool controls - PF - L1/L2

Page 23 - Spool controls - L3/L4 - Standard shafts

Page 24 - Rotary control devices - CR

Page 25 - Cable remote controls - TC

Page 25 - Direct electric push-pull control and emergency devices - E7/E8 - ES

Page 26 - Hydraulic controls - IP - IF

Page 27 - Pneumatic and electro-pneumatic controls - PP/P0 - P1/P2 - PQ

Page 28 - 29 - Electro-hydraulic controls only for one section monoblock - H1/H2 - KM12/KM24

Page 30 - Spool positionings - C2 -C3 - C4 - C5 - C6 - C7 - C8

Page 31 - Spool positionings - R2 - R4 - R5 - R6 - R7 - R9 - C0

Page 32 - Spool positionings - F1 - F2 - F3 - F4 - F5 - F6 - F7 - F8

Page 33 - Spool positionings - PM

Page 34 - Spool positionings - CE - CM - CW - CD

Page 35 - Spool positionings - G2 - G4 - G5 - G6 - G7 - G8

Page 36 - How to order - VDM6

Page 37 - Identification label

## Page 38 - WARRANTY



**When in our catalogues you will find this symbol, please read carefully**

### E0.02.0911.02.02

The data in this catalogue refers to the standard product.

The policy of Salami S.p.A. consists of a continuous improvement of its products. It reserves the right to change the specifications of the different products whenever necessary and without giving prior information.

If any doubts, please get in touch with our sales department.

### GENERAL FEATURES

Among all hydraulic directional control valves used in the field of mobile equipment applications, the spool valve is the most popular.

The monoblock valve type offers an excellent performance price ratio.

#### FEATURES

VDM6 directional control valve has the following:

- cast-iron monoblock construction up to 6 spools
- parallel circuit, load check valve protection on down-stream of the pressure "P" line
- tandem circuit, only the first working section, l.c.v. protection + l.c.v. protection on down-stream of the "P" line
- possibility of venting valve
- possibility of power beyond
- spool construction in steel, hardened and nichel-plated to obtain a higher surface hardness and a better corrosion resistance
- several types of spool: double, single acting, spool motor, float position etc.
- minimum tolerance between the spools and the body to obtain a minimum internal leakage
- interchangeability of all the spools
- several spool control devices and spool positioning devices

#### VALVE AND DEVICE TYPES

In order to meet the most stringent demands and to offer a wider range of applications, the following types of valves and devices are available:

##### Valves





- direct main relief valve: controls the maximum pressure in the circuit when one or more spools are on end stroke located on "A" port side, can be:  
direct type version up to 375 bar - 5440 psi
- electric venting valve is available as:  
12 or 24 Vdc and normally open or normally closed versions
- flow restrictor: directly fitted on the "A/B" ports orifice
- hydraulic piloted load check valve on the "A/B" ports: built-in a manifold assembled on the top of the VDM6

##### Devices

- handle controls
- cross lever: allows to acting two spools with one manual joystick
- cable remote control
- control device for microswitches: for the operation with electric d.c. motor driven pumps at one or more rotation speeds
- hydraulic kick-out: returns the spool automatically to the neutral position when the pre-set pressure of port "A" or "B" is exceeded
- anti-tilt device: the spool returns automatically in neutral position when the pressure reaches a pre-set value to avoid cranes from becoming unstable
- pneumatic proportional control available also with float position
- electropneumatic control
- hydraulic proportional control available also with float position
- direct electric on-off control with emergency manual device
- electrohydraulic on-off and proportional control, available also for 1 working section monoblock
- several spool positionings device to return the spool to neutral position or to lock the spool on working position
- rotary control



**TECHNICAL DATA**

Spools	from 1 to 7		
Nominal flow	Q	45 l/min	( 12 gpm US )
 Max flow		60 l/min	( 16 gpm US )
Max pressure	port P	350 bar	( 5100 psi )
	ports A/B	350 bar	( 5100 psi )
	 port T	25 bar	( 363 psi )
Internal leakage at 160 bar ( 2285 psi )	ports A/B → T	18 ÷ 25 cm <sup>3</sup> /min	( 1.1 ÷ 1.52 cu.in./min )
For lower leakage please contact our sales dept.			
Solenoid control 45W the leakage is		70 ÷ 90 cm <sup>3</sup> /min	( 4.3 ÷ 5.49 cu.in./min )
Solenoid control 31W the leakage is		100 ÷ 120 cm <sup>3</sup> /min	( 6.1 ÷ 7.32 cu.in./min )
Spool stroke (positions 1 and 2)		± 6 mm	( 0,236 in. )
Spool stroke (position 4, float or regenerative)		± 6 + 4 mm	( 0.236 + 0.157 in. )
For direct solenoid control - spool stroke		± 2.5 mm	( 0,098 in. )
Stroke of the overcenter spools		± 4.5 mm	( 0.177 in. )
 In case you need flows from 45 l/min to 60 l/min please contact our sales dept.			
 For higher back pressure please contact our sales dept.			
All technical data carried out using mineral oil with viscosity of 16 cSt and contamination level 19/16 as ISO 4406.			

Nominal flow meaning: flow causing 1 bar (14.5 psi) pressure drop each section, with spools in neutral position

**WORKING CONDITIONS**

Hydraulic fluid	mineral oil according to DIN 51524		
Viscosity	viscosity range	10...400 mm <sup>2</sup> /sec	( 0.15...7.13 sq.in./sec )
	optimal viscosity	12...75 mm <sup>2</sup> /sec	( 0.19...1.16 sq.in./sec )
Temperature	fluid range temperature	-20...85 °C	( -4...185 °F ) NBR seals
	suggested range	30...60 °C	( 86...140 °F ) NBR seals
Maximum contamination level	NAS 1683: class 9	ISO 4406: 19/16	
Room temperature	-30...60 °C ( -22...140 °F )		
Working limits	see diagrams at page 6		
Pressure drop	see diagrams at page 7		
For operation with fire resistant fluid, please contact our sales department			

## OPERATING PRINCIPLE

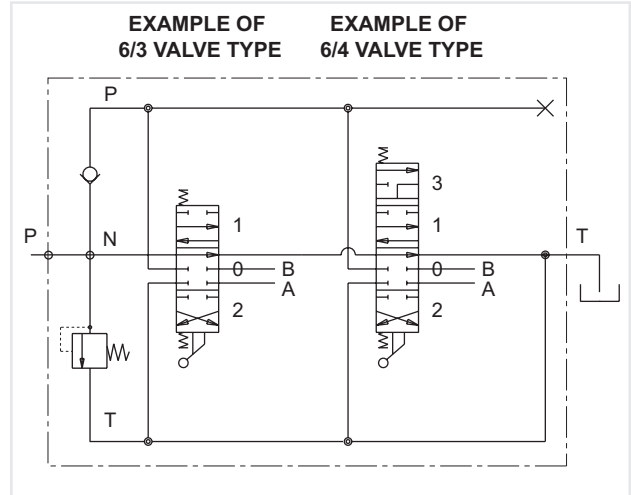
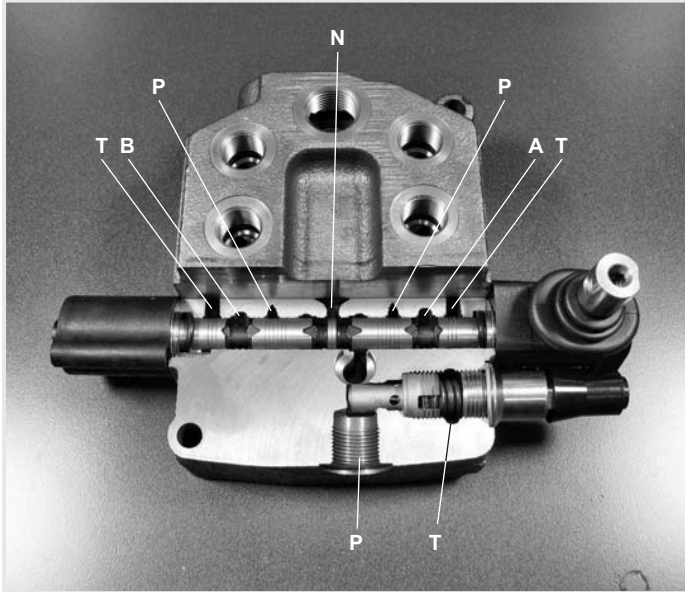

The picture show the paths N - P - A - T, the other paths are simmetrical

Salami directional control valves belong to the 6/3 (or 6/4) type; they can control 6 gallery in 3 (or 4) spool positions simultaneously.

They are open circuit types: when the spool is in neutral position, the fluid flows directly to the tank with minimum internal pressure drops (approximately 1 bar / 14.5 psi for each spool at nominal flow).

When the spool is moved from this position, the neutral gallery is gradually throttled and the connection between pump and actuator, through the corresponding port, is made.

When pressure exceeds the value of the pressure existing in port A or B, the fluid flows through the load check valve to the actuator.

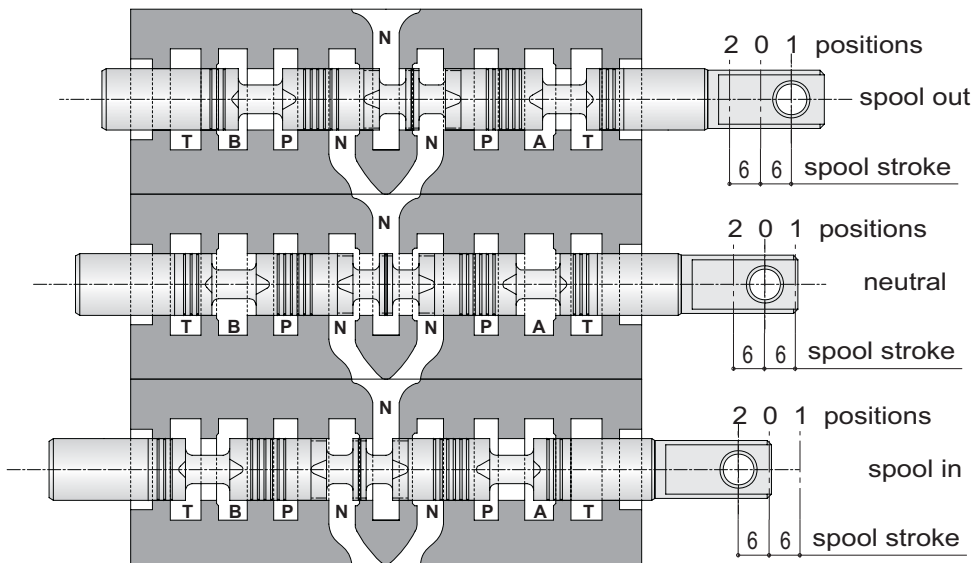

### IMPORTANT

Looking at this side of the spool, we usually say: spool in when the spool is pushed into the valve and spool out when it is pulled out of the valve.

Depending on assembling of the spool on "A" or "B" side

There are two characteristic phases in the spool stroke (6 mm - 0,236 in.):

a) the overlap phase (about 18% of the stroke) guarantees minimum internal leakages in neutral position;

b) the progressive flow regulation phase (82% of the stroke).

Both pictures show a 6/3 valve type with double acting spool only as principle of functioning.

Salami VDM6 is available in different solutions.



**HYDRAULIC FLUIDS**

Usually a mineral-base oil with a good viscosity index should be used, preferably with good lubricating properties and corrosion, oxidation and foaming resistant.

Sometimes the fluids supplied by the manufacturers do not satisfy purity requirements (see page 3 WORKING CONDITIONS). It is therefore necessary to filter the fluid carefully before filling. Your supplier can give you the information about NAS class of its fluids. To maintain the proper purity class, the use of filters of high dirt capacity with clogging indicator is recommended.

Under humidity conditions it is necessary to use hygroscopic salts.

For operation with fire resistant and ecological fluids, please contact our technical department.

**INSTALLATION**

When proceeding to mount the unit on the structure and to connect fittings to work ports, it is necessary to comply with the values of tightening torques.

The attachment of linkages to spools should not affect their operation. The mounting position can be vertical with inlet module on the top or horizontal.

**Standard tightening torques - Nm / lbft**

FITTING TYPE	P and PL ports	A and B ports	T and TL ports
BSP (ISO 228/1)	G 3/8	G 3/8	G 1/2
with o-ring seal	30 / 22.1	30 / 22.1	50 / 36.9
with copper washer	40 / 29.5	40 / 29.5	60 / 44.2
with steel washer	40 / 29.5	40 / 29.5	60 / 44.2
SAE	SAE 8 (3/4-16 UNF)	SAE 8 (3/4-16 UNF)	SAE 10 (7/8-14 UNF)
with o-ring seal	30 / 22.1	30 / 22.1	60 / 44.2

**FILTRATION**

The contamination of the fluid in the system greatly affects the life of the unit. Above all, contamination may result in irregular operation, wear of seals in valve housings and failures. Once the initial contamination level of the system has been reached, it is necessary to limit any increase of contamination installing an efficient filtration system (see working conditions page 3).

**PIPES**

Pipes should be as short as possible, without restrictions or sharp bends (especially the return lines). Before connecting pipes to the fittings of the corresponding components, make sure that they are free from burrs and other contamination.

As a first approximation, for a mobile machine with standard length pipes, their width should guarantee the following values of fluid speed\* :

6 ÷ 10 m/sec  
3 ÷ 5 m/sec

inlet pipe  
outlet pipe

19,7 ÷ 32,8 ft/sec  
9,9 ÷ 16,4 ft/sec

inlet pipe  
outlet pipe

the lowest values of fluid speed are required in case of wide temperature range and/or for continuous duty.

$$* [v = \frac{21,2 \times Q}{d^2}] \quad v = \text{fluid speed [m/sec]}, \quad Q = \text{flow [l/min]}, \quad d = \text{pipe internal diameter [mm]}$$

## PERFORMANCE DATA

The characteristics in this catalogue are typical measured results.  
During measuring a mineral based hydraulic oil with a viscosity of 16 cSt at a temperature of 50°C was used.

**FOR FURTHER DETAILS PLEASE CONTACT OUR SALES DEPARTEMENT**

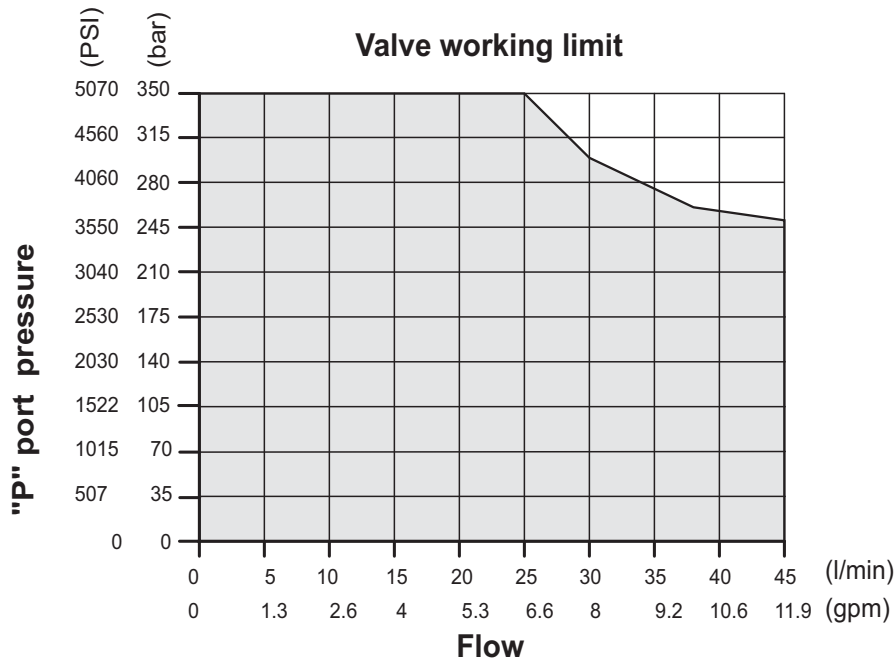
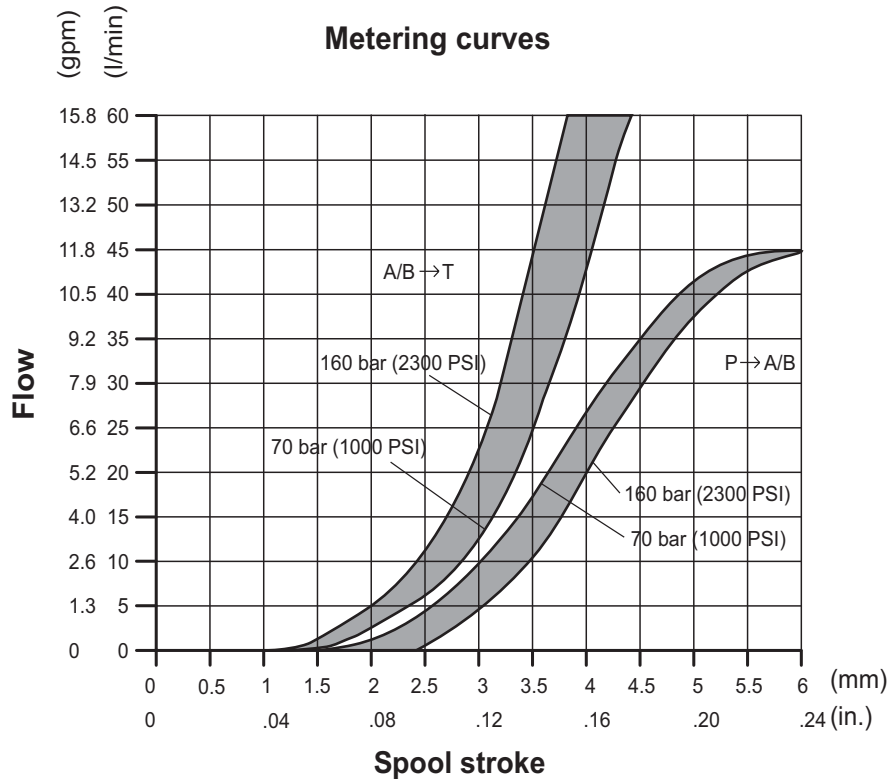

The data of this diagram have been obtained with a force of:  
stroke beginning 80 N - stroke end 105 N and standard leakage data.





**PERFORMANCE DATA**

The characteristics in this catalogue are typical measured results.  
During measuring a mineral based hydraulic oil with a viscosity of 16 cSt at a temperature of 50°C was used.

**FOR FURTHER DETAILS PLEASE CONTACT OUR SALES DEPARTEMENT**

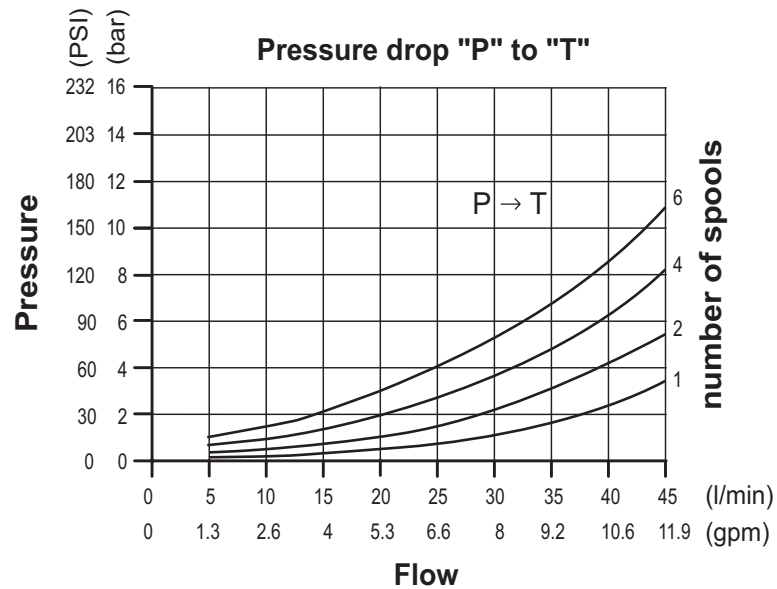
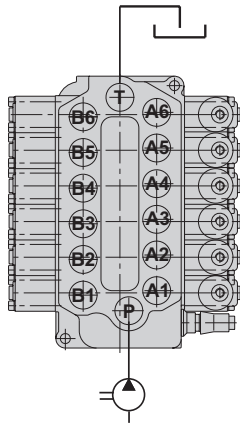

**Pressure drop "P" to "A1/B1" and to "A6/B6"**  
**Pressure drop "A1/B1" and "A6/B6" to "T"**

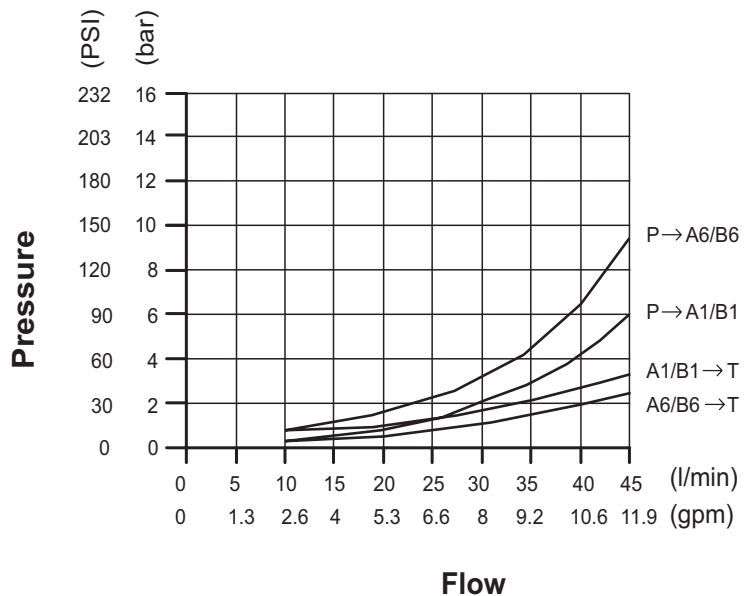
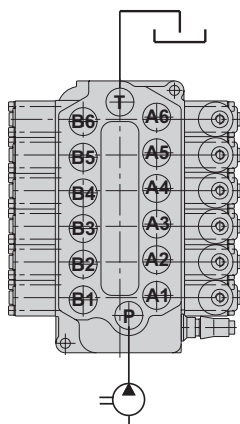

### DIMENSIONS FROM 2 TO 7 SECTIONS MONOBLOCK

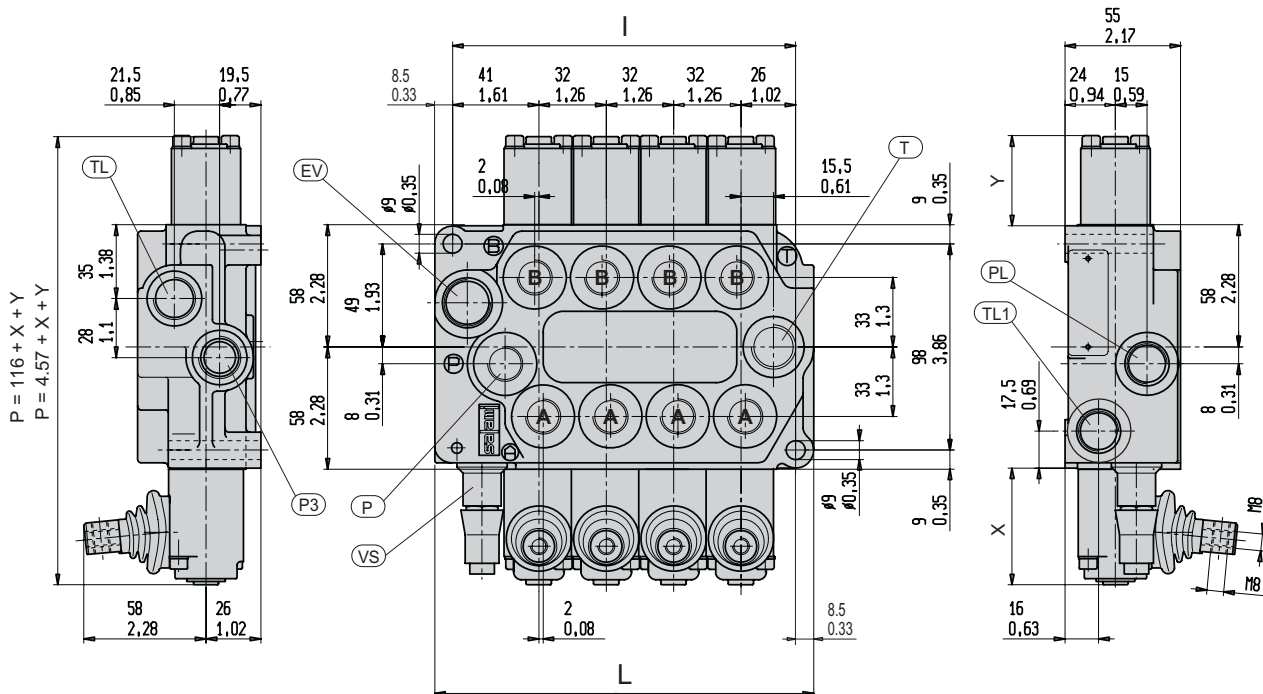

The drawing shown is just an example. The overall dimensions you read are valid for all the VDM6 except the parametric dimensions "L" and "I" depending of the number of working sections. The parametric dimension "P" depends on a fixed dimension of 116 mm (4.57 in.) to which you have to add the "X" and "Y" dimensions that you can find in the spool controls and spool positionings pages.

#### INDEX:

- P** = top inlet port
- PL** = side inlet port
- T** = top outlet port
- TL** = side outlet port
- TL1** = side outlet port
- A/B** = work ports
- P3** = power beyond port
- VS** = main relief valve
- EV** = seat for venting valve

Spools		1	2	3	4	5	6	7	8
<b>I</b>	mm	/	99	131	163	195	227	259	/
	in	/	3.90	5.16	6.42	7.68	8.94	10.2	/
<b>L</b>	mm	/	116	148	180	212	244	276	/
	in	/	4.57	5.83	7.09	8.35	9.61	10.87	/
<b>Weight</b>	Kg.	/	4.5	5.7	7.5	9.3	9.9	10.9	/
	lb.	/	9.9	12.6	16.5	20.5	21.8	24	/

PORT SIZES	P - PL - TL1 - P3	T - TL	A - B
BSP ISO 228	G 3/8	G 1/2	G 3/8
SAE ISO 176	SAE#8 3/4 - 16 UNF	SAE#10 7/8 - 14 UNF	SAE#8 3/4 - 16 UNF
ISO 262 - ISO 6149	M 18 x 1.5	M 22 x 1.5	M 18 x 1.5
BSPF JIS B 2351	G 3/8	G 1/2	G 3/8

For smaller or bigger thread ports, please contact our sales department.

**DIMENSIONS FOR 1 SECTION MONOBLOCK**

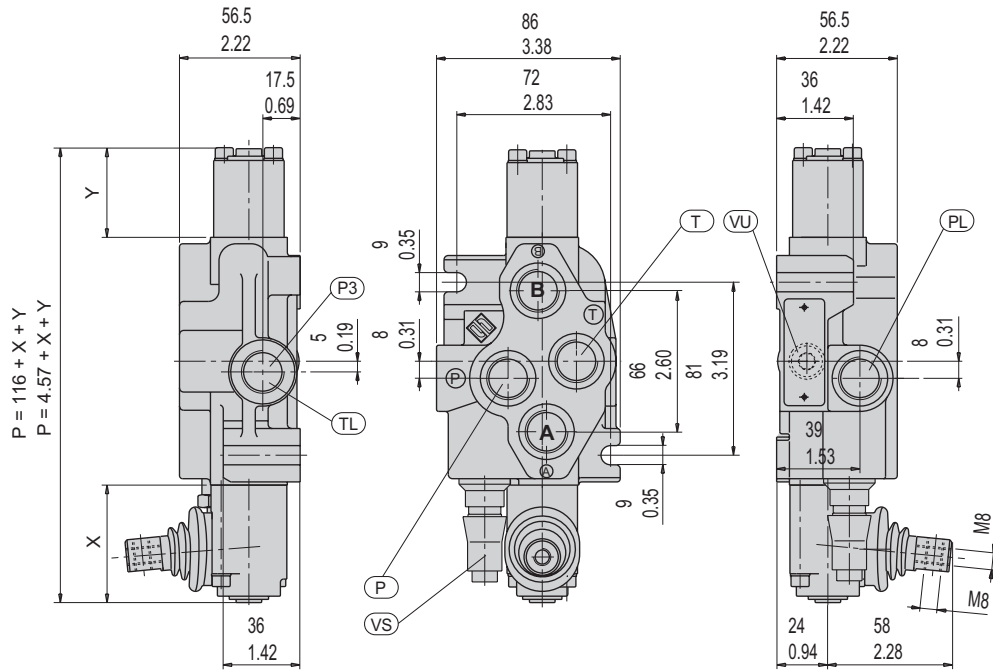

The parametric dimension "P" depends on a fixed dimension of 116 mm (4.57 in.) to which you have to add the "X" and "Y" dimensions that you can find in the spool controls and spool positionings pages. In this monoblock the main relief valve can be assembled only on "A" side.

**INDEX:**

- P** = top inlet port
- PL** = side inlet port
- P3** = side outlet port for power beyond
- T** = top outlet port
- TL** = side outlet port
- A/B** = work ports
- VS** = main relief valve(adjustable)
- VU** = load check valve

The one working section monoblock is always pre-arranged for power beyond just adding a dowel 3/8" - 18 NPTF

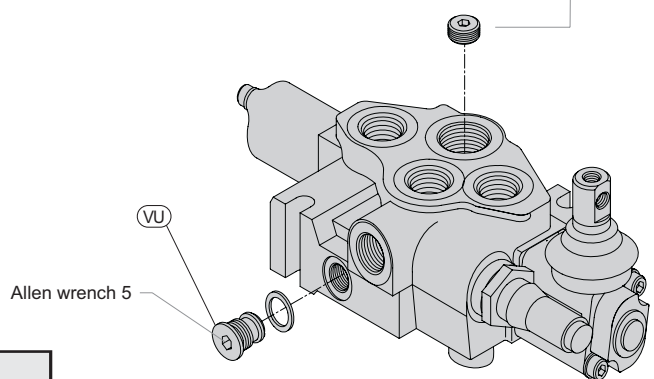

**Weight = 2.8 Kg - 6.17 lb.**

PORT SIZES	P - PL - TL1 - P3	T - TL	A - B
BSP ISO 228	G 3/8	G 1/2	G 3/8
SAE ISO 176	SAE#8 3/4 - 16 UNF	SAE#10 7/8 - 14 UNF	SAE#8 3/4 - 16 UNF
ISO 262 - ISO 6149	M 18 x 1.5	M 22 x 1.5	M 18 x 1.5
BSPF JIS B 2351	G 3/8	G 1/2	G 3/8

For smaller or bigger thread ports, please contact our sales department.

## PORTS

Following are standard ports. For different port types, please contact our sales department.

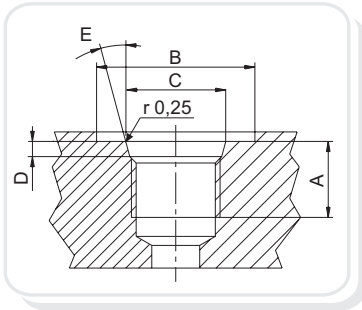

SAE UN-UNF (ISO 725)							
Dimensions		9/16 - 18 UNF SAE6		3/4 - 16 UNF SAE8		7/8 - 14 UNF SAE10	
mm	In.						
A		13	0,51	15	0,59	17	0,67
B		25	0,83	30	1,18	34	1,34
C		15,6	0,61	20,6	0,81	23,9	0,94
D		2,5	0,10	2,5	0,10	2,5	0,10
E		15°		15°		15°	

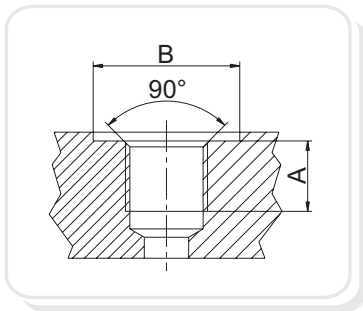

BSP (ISO 228)							
Dimensions		G1/4		G3/8		G1/2	
mm	In.						
A		14	0,55	14	0,55	16	0,63
B		19	1,75	23	1,91	27	1,06

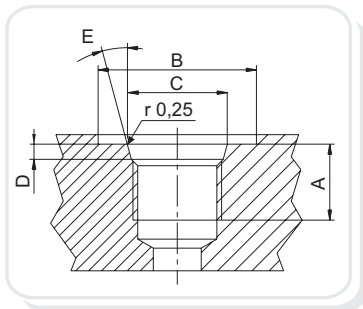

METRIC (ISO 262 - ISO 6149)*									
Dimensions		M18 x 1.5				M22 x 1.5			
mm	In.	ISO 262		ISO 6149		ISO 262		ISO 6149	
A		14	0,55	14,5	0,57	16	0,63	16	0,63
B		27,5	1,08	29	1,14	31,5	1,24	34	1,34
C				19,8	0,78			23,8	0,94
D				2,4	0,09			2,4	0,09

\*Available for quantity, please contact our sales dept.

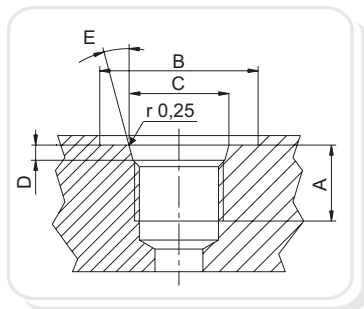

BSPF O-RING BOSS (JIS B 2351)							
Dimensions		G 1/4		G 3/8		G 1/2	
mm	In.						
A		12	0,47	12	0,47	16	0,63
B		24	0,94	28	1,10	34	1,34
C		15,6	0,61	18,6	0,73	22,6	0,89
D		2,5	0,10	2,5	0,10	2,5	0,10
E		15°		15°		15°	

**INLET AND OUTLET TYPES (HYDRAULIC CIRCUITS)**

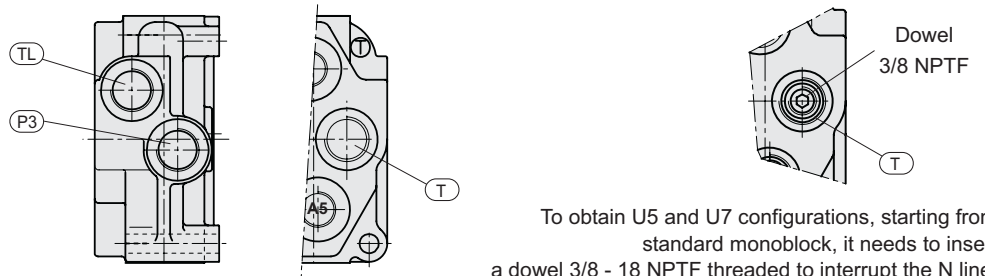
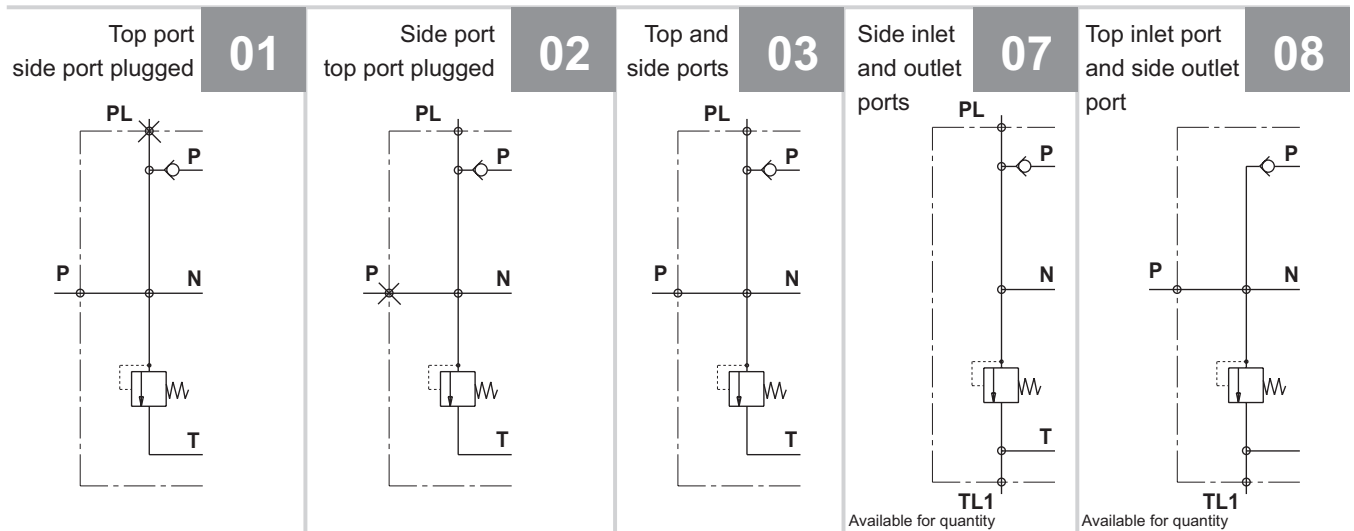
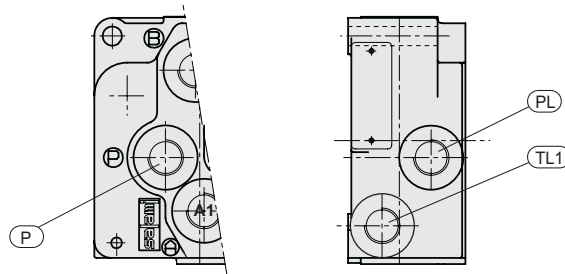

To obtain U5 and U7 configurations, starting from standard monoblock, it needs to insert a dowel 3/8 - 18 NPTF threaded to interrupt the N line.

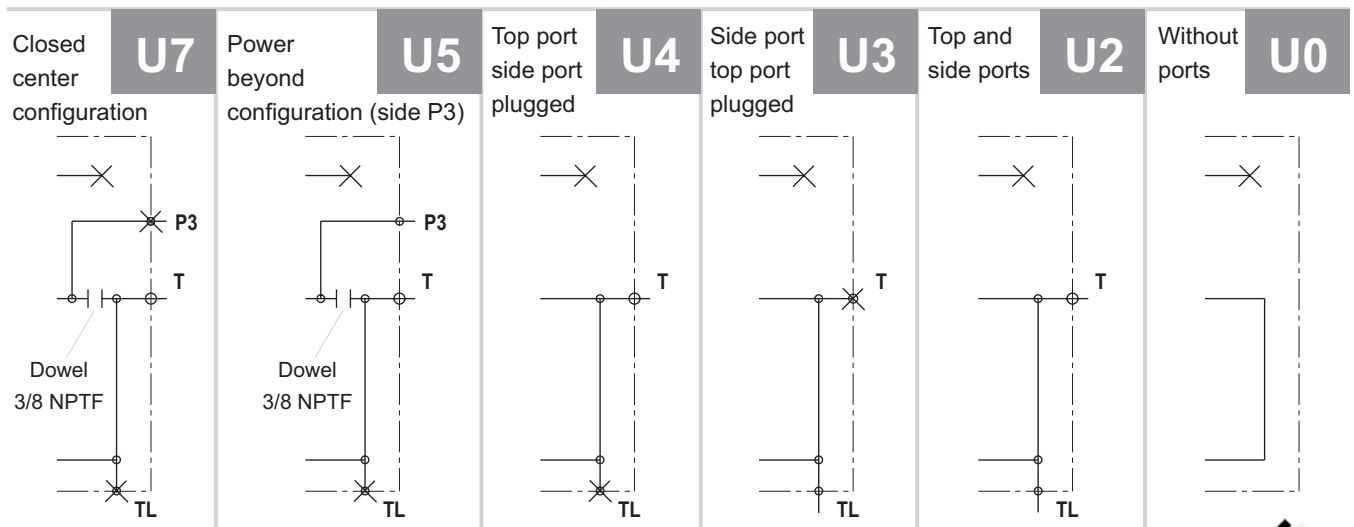

## WORKING SECTIONS (HYDRAULIC CIRCUITS)

**P**

Parallel circuit, load check valve protection on down-stream of the pressure "P" line can be from 1 to 7 working sections

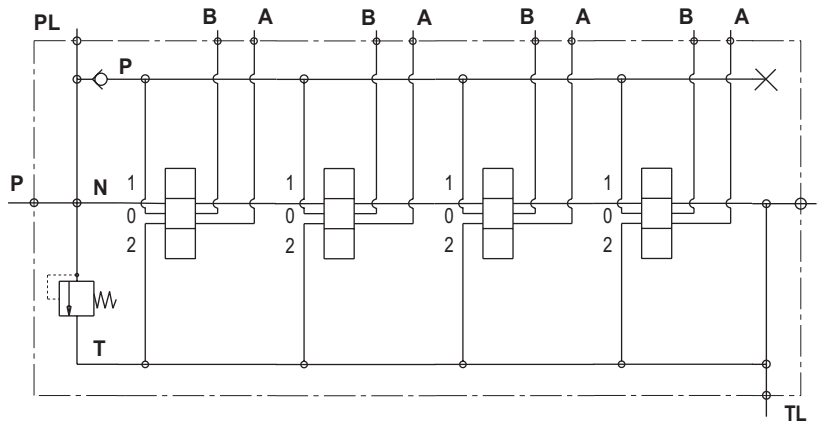

**T**

Tandem circuit only in the first working section, load check valve protection of the first section, load check valve protection on down-stream of the pressure "P" line (parallel circuit) can be from 2 to 4 working sections

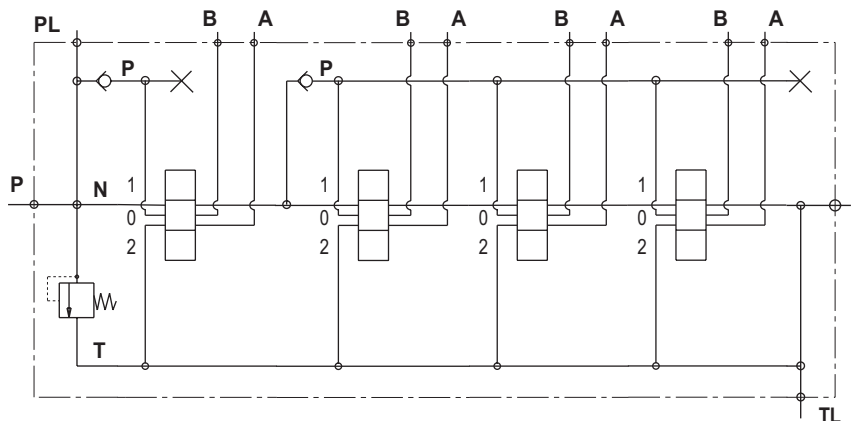

This type of circuit is available only for quantity, please contact our sales department.



### CIRCUIT AND SPOOL TYPES

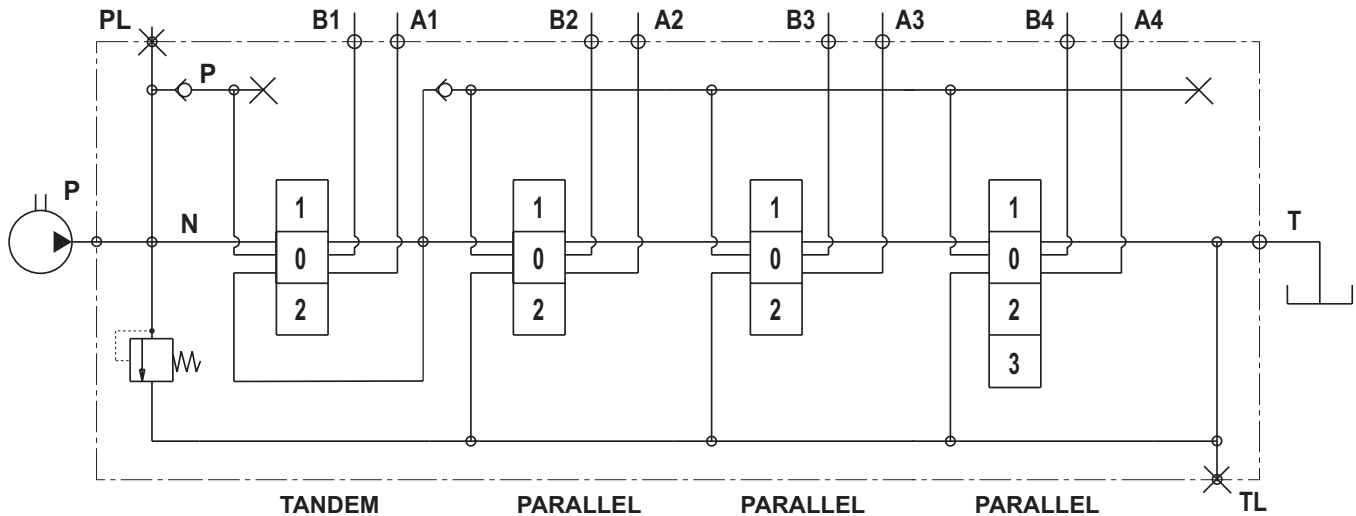

The circuits available are:

parallel type, tandem type only in the first working section as shown in the picture above (see page 12). You can have main relief valve and venting valve in the inlet (see pages 16 and 17).

The spools can be 3 or 4 positions (as shown here below) moreover VDM6 is available for power beyond just insert a plug 1/4" - 18 NPTF (see page 11).

As you can read at page 37, the spools can be types "A" nominal flow or "C" 2/3 of nominal flow.

01		Double acting spool	Double acting motor spool		02
03		Double acting motor spool ("B" port blocked)	Double acting motor spool ("A" port blocked)		04
05		Single acting spool "A" working port	Single acting spool "B" working port		06



<p><b>11</b></p>	<p>Double acting spool with float function in 3rd position (spool in)</p>	<p>Double acting spool with float function in 3rd position (spool out)</p>	<p><b>12</b></p>
<p><b>13</b></p>	<p>Double acting spool with regenerative function in 3rd position (spool in)</p> <p>With this type of spool a special machining of the body is required</p>		
<p><b>17</b></p>	<p>Double acting spool with regenerative function in position 2 (spool in)</p> <p>With this type of spool a special machining of the body is required</p>	<p>Double acting spool with regenerative function in position 1 (spool out)</p> <p>With this type of spool a special machining of the body is required</p>	<p><b>18</b></p>
<p><b>52</b></p>	<p>Over center double acting spool "A" working port</p> <p>The stroke of this type of spool is <math>\pm 4.5</math> mm</p>	<p>Over center double acting spool "B" working port</p> <p>The stroke of this type of spool is <math>\pm 4.5</math> mm</p>	<p><b>53</b></p>
<p><b>54</b></p>	<p>Over center double acting spool "A and B" working ports</p> <p>The stroke of this type of spool is <math>\pm 4.5</math> mm</p>		

Salami standard spools have the ends as shown in this drawing. These ends spool are necessary to join it the controls and the positionings. With direct electric and hydraulic controls the ends spool are different as you can see at pages 25 and 26.

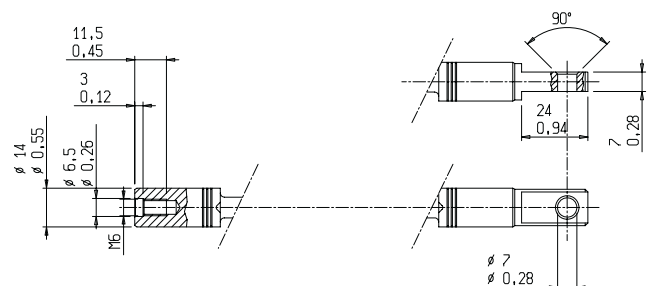

## MAIN RELIEF VALVES

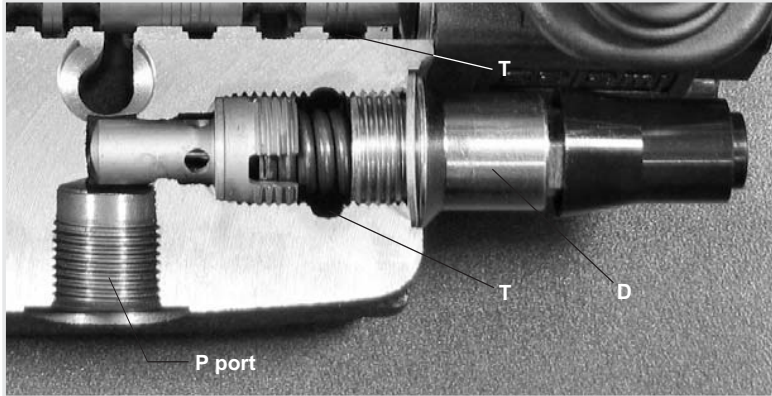

Max tightening torque:  
 wrench 10 - 18 Nm  
 wrench 13 - 24 Nm  
 wrench 22 - 35 Nm  
 wrench 24 - 30 Nm  
 wrench 26 - 30 Nm  
 wrench 27 - 30 Nm  
 Allen wrench 6 - 30 Nm  
 Allen wrench 8 - 30 Nm

The main relief valve can be mounted only on "A", in case of venting valve there is an appropriate cavity on the top of VDM6. All the testing values of this page have been obtained with nominal flow of 35 L/min - 9.25 gpm, viscosity 16cST and oil temperature 50°C - 122°F.

### D

**MAIN RELIEF VALVE DIRECT OPERATED**  
 (setting range from 51 to 350 bar - 740 to 5100 psi)  
 available in two type, see drawing here below

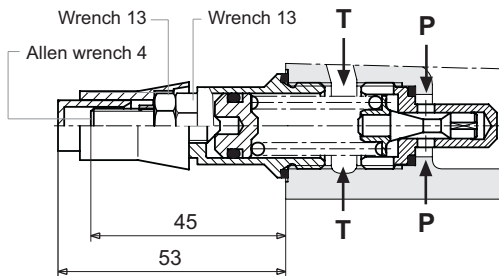
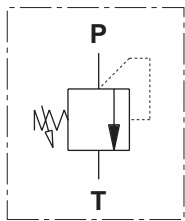

TYPE 1

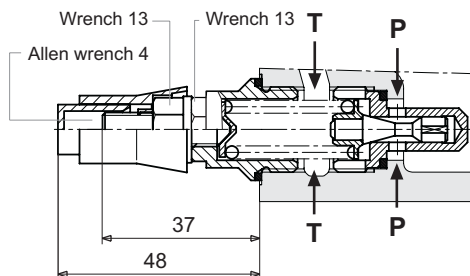

TYPE 2

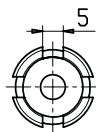

First part of the valve

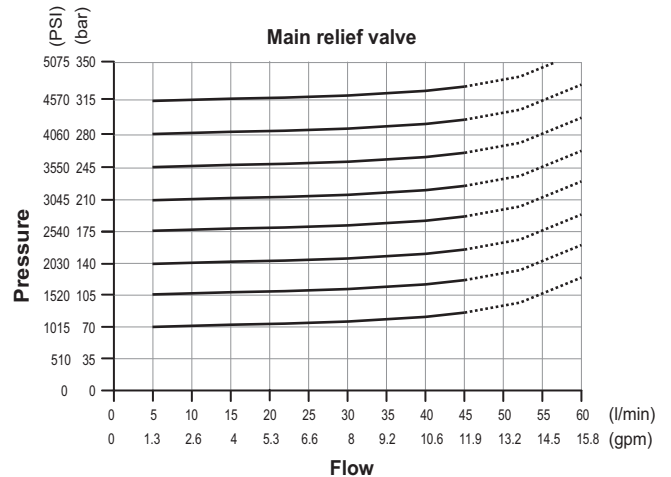

This valve is built as shown in the drawing here below:

- washer - 1
- first part - 2
- shutter - 3
- spring - 4
- second part - 5
- sealing plug - 6

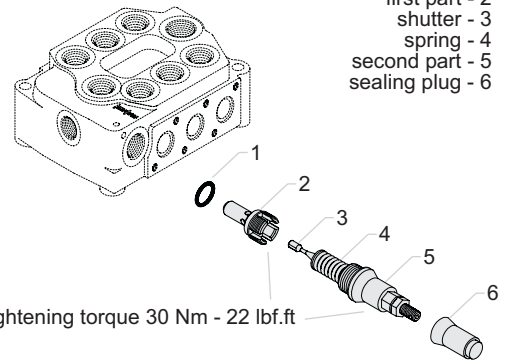

Tightening torque 30 Nm - 22 lbf.ft

The only difference between the two types is the type 1 is adjustable without oil leaking.

### W

**PLUG FOR MAIN RELIEF SEAT WITHOUT VALVE**

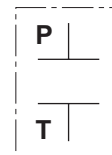
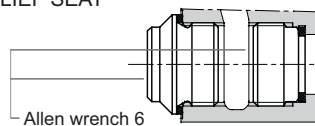

## VENTING VALVES

This valve is located in an appropriate cavity on the top of VDM6 from 2 to 6 sections, see page 8. It can be assembled with or without main relief valve. For all the test conditions, please refer you to page 16.

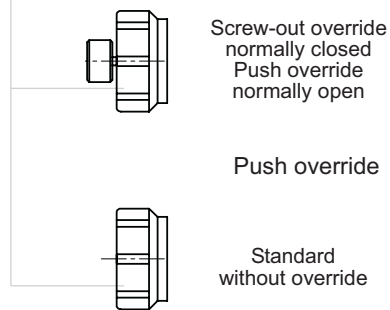
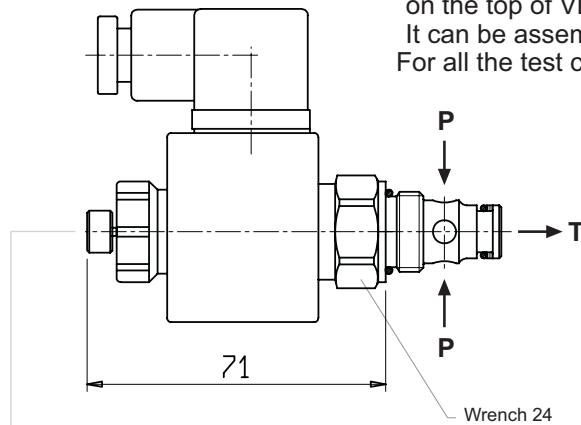

CONNECTOR  
DIN 43650 - A/ISO 4400

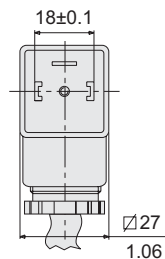

### SPECIFICATIONS

- MAX PRESSURE IN "P"	350 bar
- MAX FLOW	40 l/min
- OIL LEAKAGE-max pressure - 46 cST	0.30 cm <sup>3</sup> /min
- AVAILABLE VOLTAGE	12 - 24 Vcc
- COIL RESISTANCE	12Vdc:8.7Ω - 24Vdc:33Ω
- COIL POWER	17 W
- PROTECTION INDEX WITH STANDARD CONNECTOR	IP 65

### EV1

12 Vdc - Normally opened  
Push override, on request

### EV2

24 Vdc - Normally opened  
Push override, on request

### EV3

12 Vdc - Normally closed  
Screw-out override, on request

### EV4

24 Vdc - Normally closed  
Screw-out override, on request

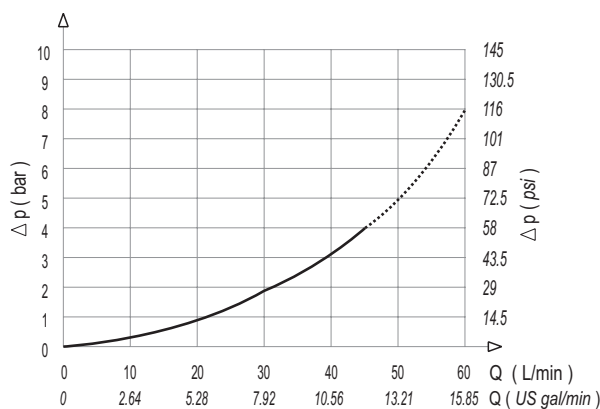

### Normally opened

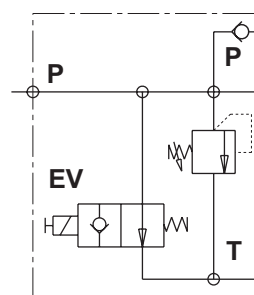

### Normally closed

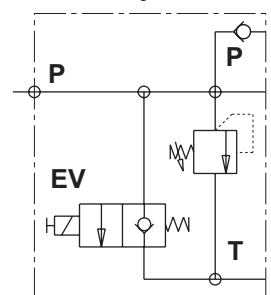

## HYDRAULIC PILOTED LOAD CHECK VALVE

### VUP

AVAILABLE ONLY FOR QUANTITY, PLEASE CONTACT OUR SALES DEPARTMENT

Built-in a manifold assembled on the top.  
Zero leakage, lock the load in position when the spool is in neutral ( 0 position).  
As you can see in the circuit here below, the opening of VUP is caused by the pressure of the ports.

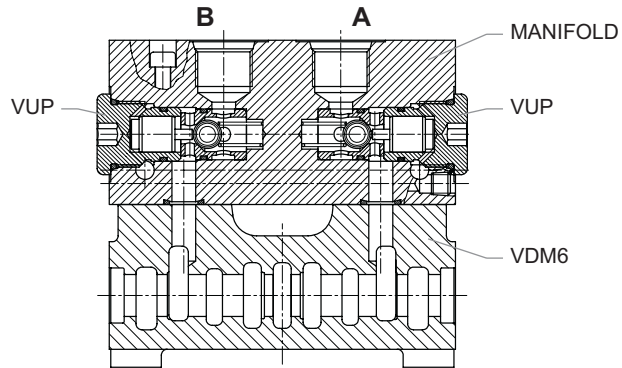
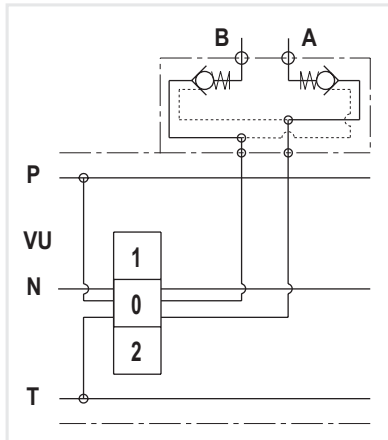

SECTIONAL VIEW

### Assembling recommendations

The monoblock you need to install the manifold is a special machined monoblock.  
The manifold with double VUP valve can be assembled on all the working sections, but not consecutive working sections.  
Remember that in case you need to install it in the first working section you must have also the inlet port PL.  
At the same way if you need to install it in the last section you must have also the outlet ports TL and TL1.

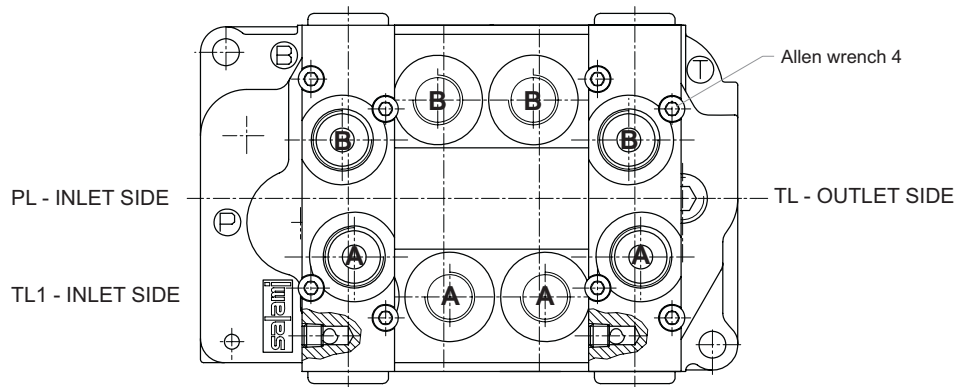

**OTHER VALVES**

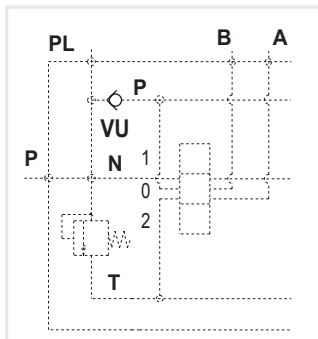

This is the load check valve VU which is built in the monoblock at the down-stream of the pressure line P and you need not to specify in phase of ordering because it is part of it. In the tandem circuit working section (available only in the first section) you have another load check valve as you can see in the hydraulic circuit of page 12.

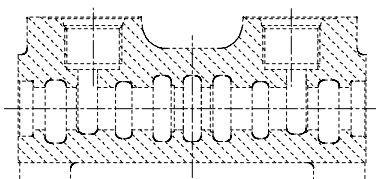
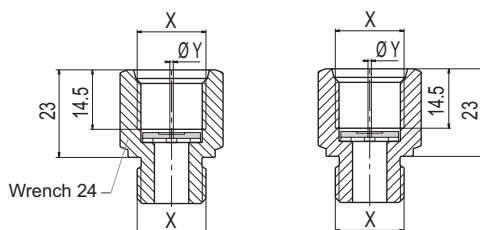
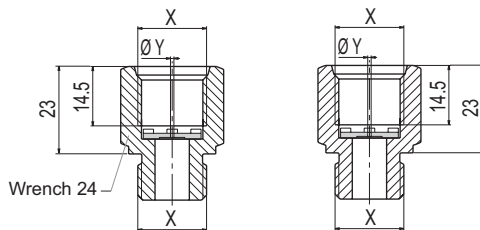
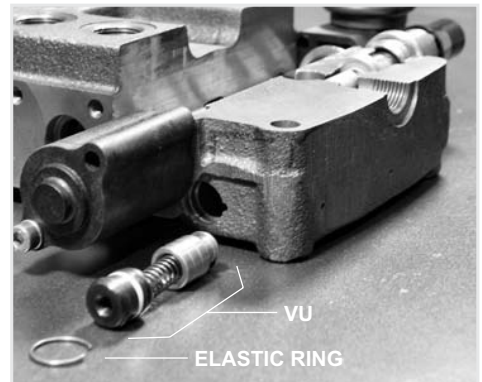

For tightening torque, please refer you to page 5.

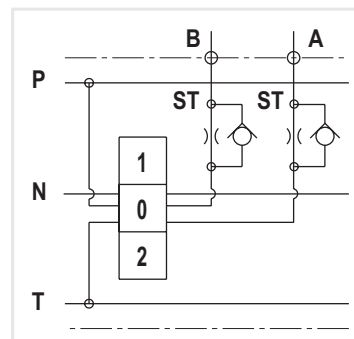

**SP**

Flow restrictor P → A/B

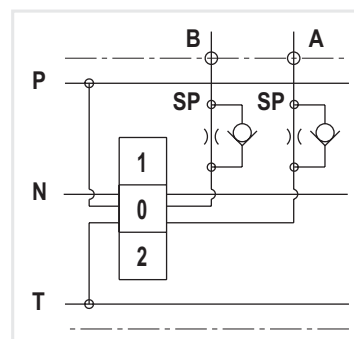

**ST**

Flow restrictor A/B → T

X		φ Y		
available threads		available measures		
*M18 x 1.5	SAE 8	G 3/8	φ 1.10	φ 1.25 φ 1.50

\*Available for quantity, please contact our sales dept.

### SPOOL CONTROLS AND SPOOL POSITIONINGS

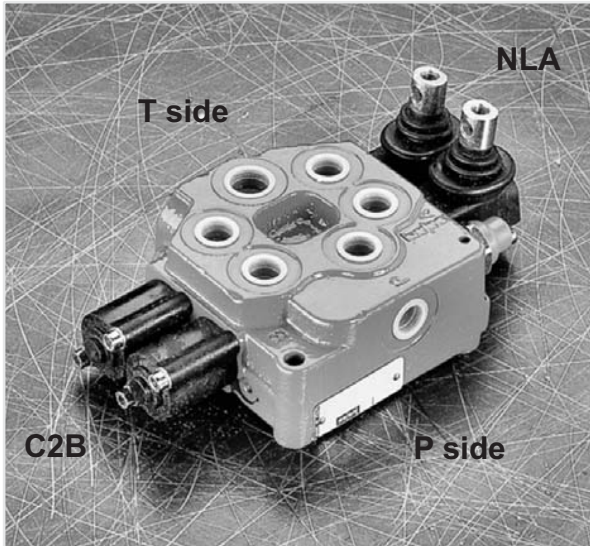

This picture shows the VDM6 assembled, in this case you have a manual control "NL" on A side and a spring return in neutral position "C2" on B side. Considering that VDM6 is a simmetrical valve, all spool controls and positionings can be placed on both sides A or B. In case of hydraulic kick-out "G2 - G4 - G5" and with spools types 13 - 17 - 18, you can also decide from A or B side but after that this is the final position because with this type of control and spools the monoblock have a special machining.

In this and following pages you can find all spool controls and spool positionings, they are all assembled with socket hexagon head screw or in some case hexagon head screw: **M5 x 0.8 with tightening torque of  $4.5 \pm 0.5$  Nm.**

The drw. here below show the reference to fix A and B side from the point of view of the operator.



**VDM6 - 6 working sections**  
with cross levers for 2 spools  
**L1/L2** and **NL** controls

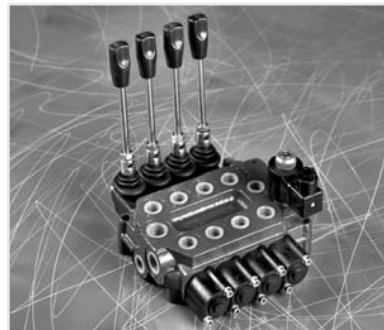

**VDM6 - 4 working sections** with  
venting valve **EV...**, **NL** controls  
and **C2** positionings

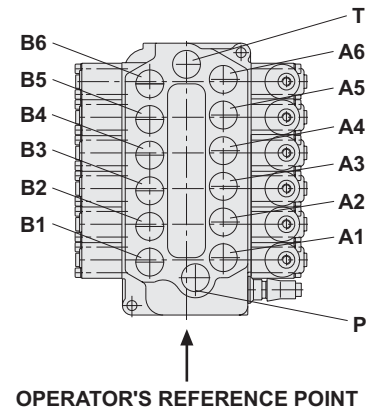

**VDM6 - 1 working section**  
with **NL** control and **CM**  
positioning spool

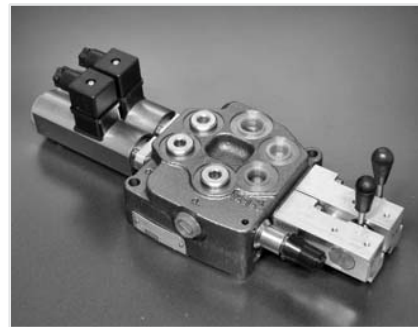

**VDM6 - 2 working sections**  
with solenoid push-pull control **E7/E8**  
and safety lever **ES**

**SPOOL CONTROLS**

For spool with float position  
commercial code **12**

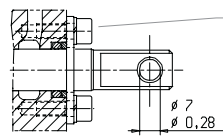

For spool with float position  
commercial code **11**

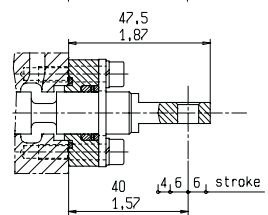
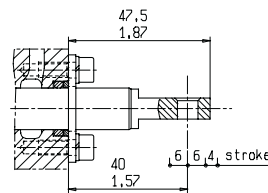
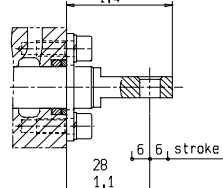

**SL**

Without lever box

- 1
- 0
- 2

On request available with dust proof plate

This lever can be assembled turned of 180°

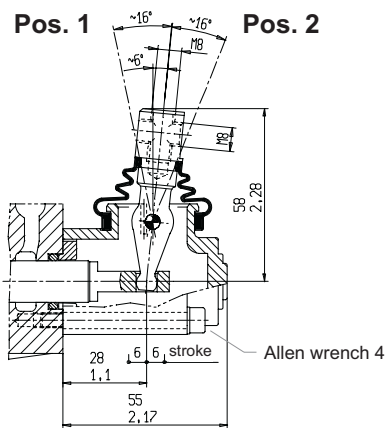

**NL**

Standard  
protected lever

- 1
- 0
- 2

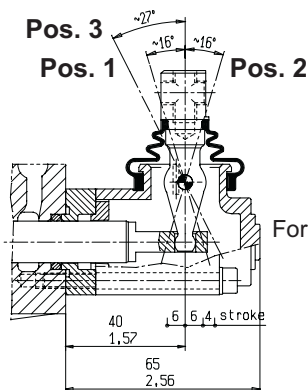

For spool with float position  
commercial code **12**

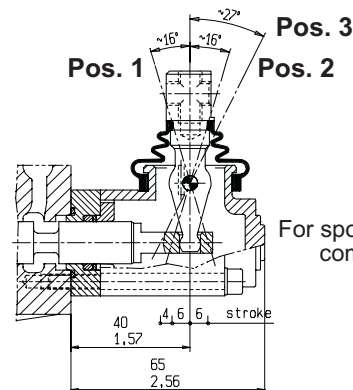

For spool with float position  
commercial code **11**

On request available for spools with float  
position: commercial codes 11 and 12 as  
shown in the drawing above

This lever can be assembled turned of 180°

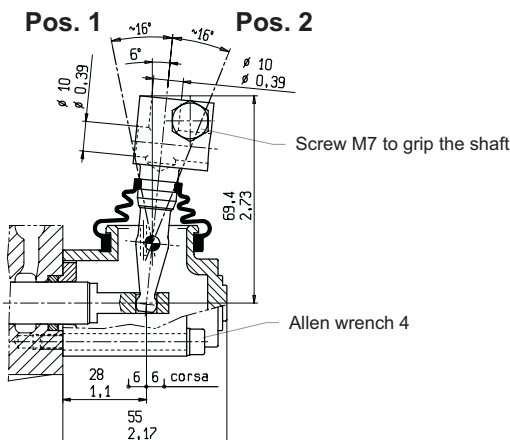

**MP**

Protected clamp lever

- 1
- 0
- 2

## PF

Not protected lever

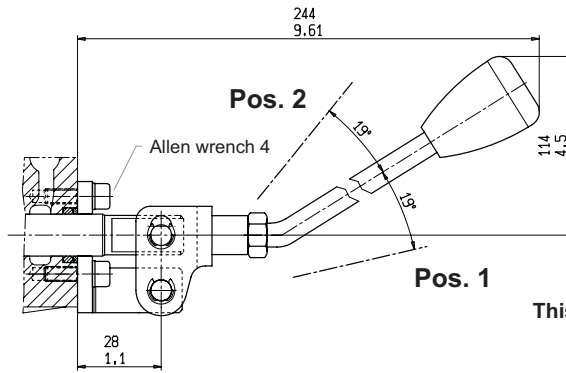

This lever can be assembled turned of 180°

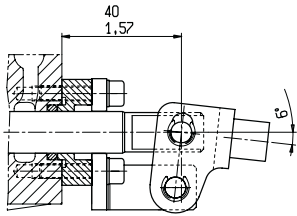

For spool with float position  
commercial code 12

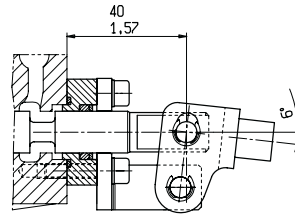

For spool with float position  
commercial code 11

## L2

Cross lever for 2 spools  
fulcrum on down-stream spool

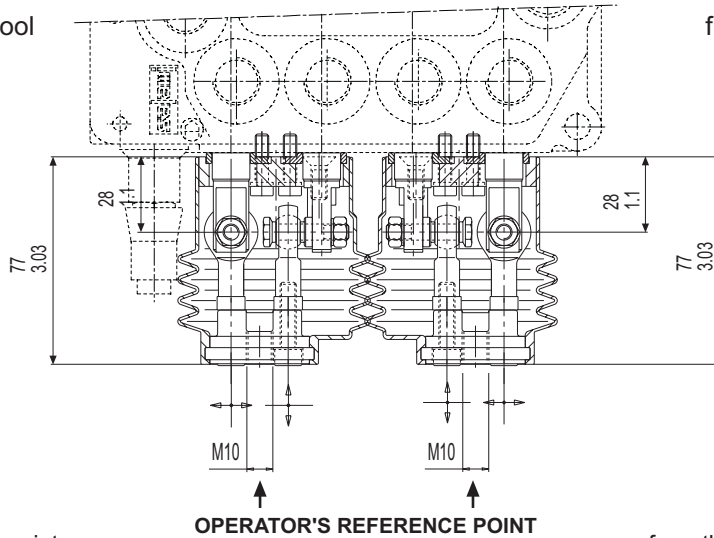
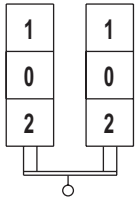

OPERATOR'S REFERENCE POINT

Standard movements  
from the operator's reference point

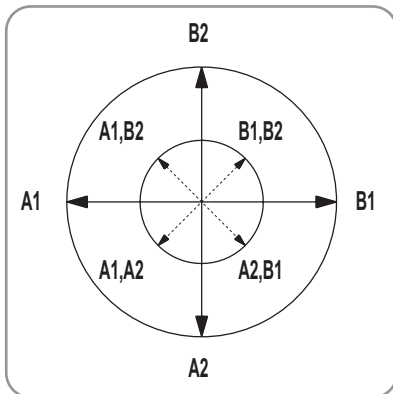

## L1

Cross lever for 2 spools  
fulcrum on up-stream spool

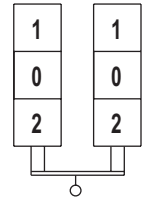

Standard movements  
from the operator's reference point

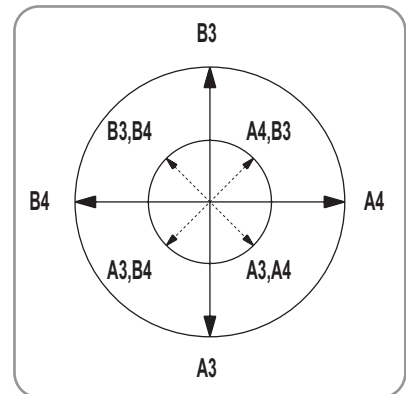



## L4

Cross lever for 2 spools  
fulcrum and spool with  
(float-in) position  
on down-stream  
working module

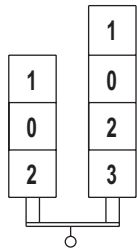

Standard movements  
from the operator's reference point

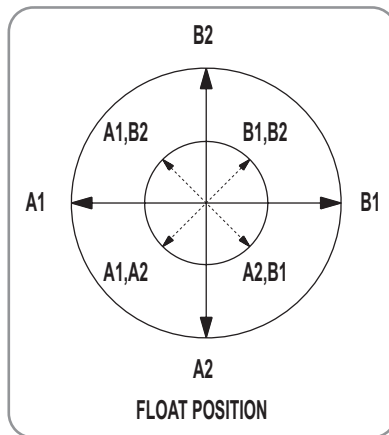

## L3

Cross lever for 2 spools  
fulcrum and spool with  
(float-in) position  
on up-stream  
working module

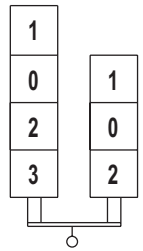

Standard movements  
from the operator's reference point

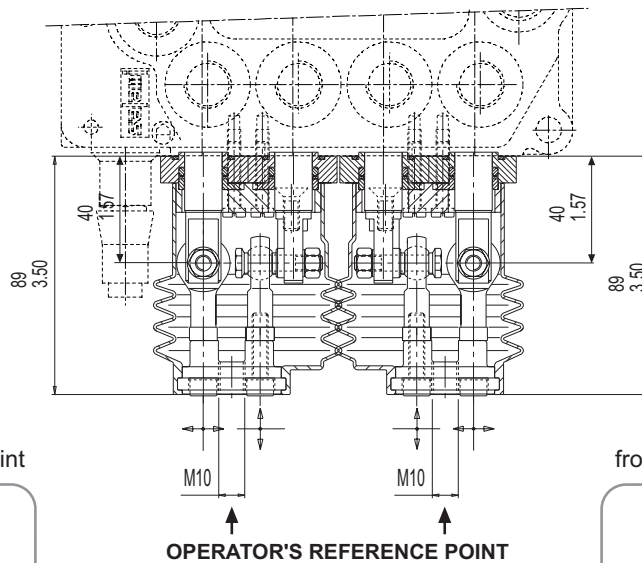
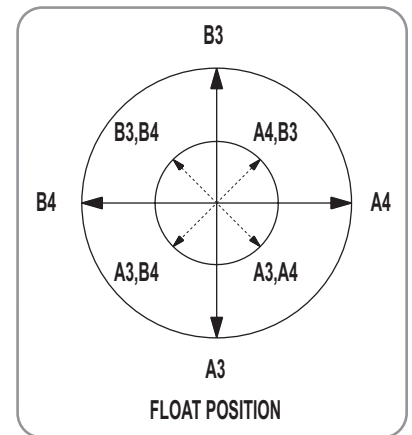

↑ OPERATOR'S REFERENCE POINT

### IMPORTANT

the double acting spool assembled with double acting + (float in) position is longer than a standard spool. In case you need joystick with double acting spool + (float out) position, please get in touch with our technical department.

## STANDARD SHAFTS

For different diameter and/or length, please get in touch with our sales dept.

Shaft with ergonomic knob  
for cross lever L1/L2  
**R202 8996 0**

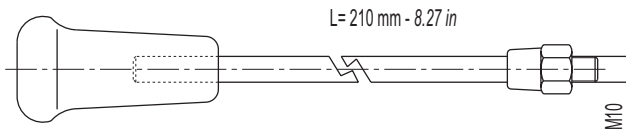

Shaft with threaded end  
**R202 9018 0**

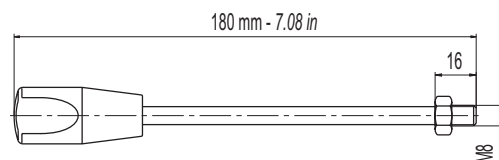

Shaft for clamp lever  
**R202 8839 0**

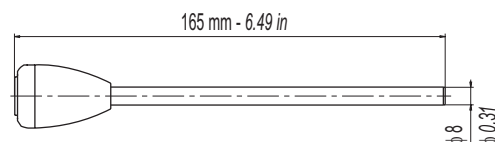

**CR**

Rotary control, available for 1 working section or two working section but one at the opposite side of the other.  
This device is realized for marine applications, so all the material components are corrosion proofing.  
This control uses special type spools, available types are: 01 - 02. Mountable on both side (A or B).

Device with cam  
and adjustable friction  
detent + rotary lever

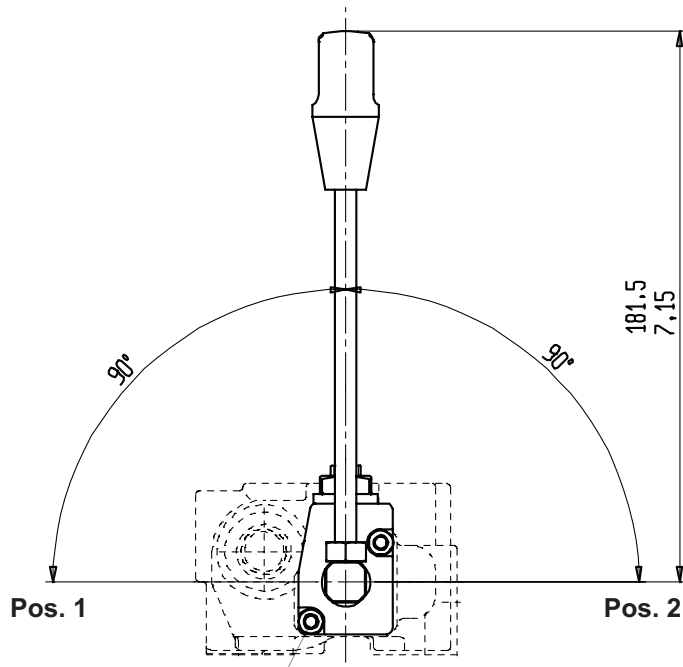
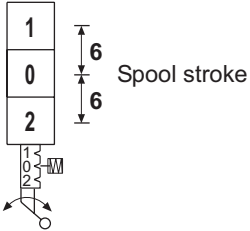

Allen wrench 4

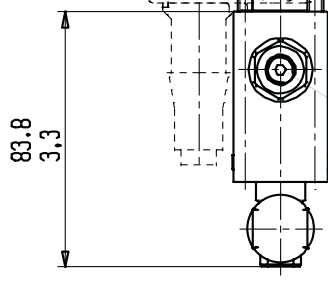
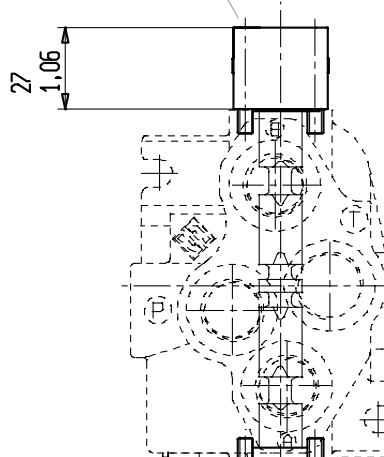

Screwing the socket hexagon 3 mm dowel,  
the friction detent is increased

# DIRECTIONAL CONTROL VALVE MONOBLOCK TYPE

# VDM6

Devices for cable remote control .  
For more details about cables, please consult our catalogue  
cable remote controls.

**TC**

For spool with (float-in) and (float-out) positions  
commercial codes **11 - 12**

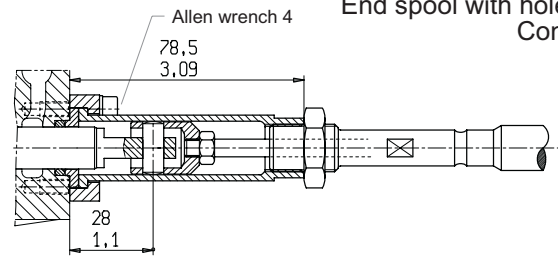
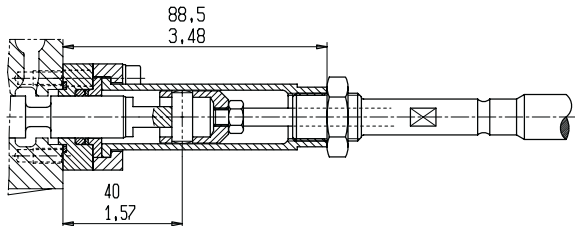

End spool with hole  $\phi$  7 mm.  
Controls side



**E9**

**Working conditions for this control:**

Flows up to 40 l/min (10.6 gpm)  
Pressure up to 210 bar (3050 psi)

Electric push-pull control 3 positions  
12 Vdc (coil power 45 Watt at 20°C)

**E10**

**Working conditions for this control:**

Flows up to 40 l/min (10.6 gpm)  
Pressure up to 210 bar (3050 psi)

Electric push-pull control 3 positions  
24 Vdc (coil power 45 Watt at 20°C)

**ELECTRIC DATA**

- STANDARD COIL POWER: 45 Watt at 20°C
- HEAVY DUTY 80%
- OPTIONAL COIL POWER: 31 Watt at 20°C
- HEAVY DUTY 100%
- PROTECTION INDEX WITH CONNECTOR: IP 65

**SL**

Without lever for electric  
push-pull control  
with override device

The available spools are from 01 to 06.

The working data a side are referred  
to the working conditions of page 3.

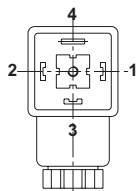

**CONNECTOR  
DIN 43650 - A/ISO 4400**

To avoid an excessive wearing of the  
contacts, depending on the sparking  
of these parts, we suggest a suitable  
protection( for example diodes)

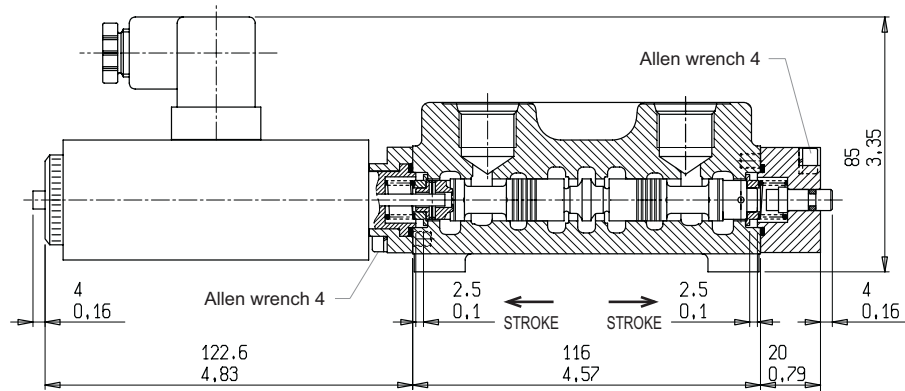

**ES**

**E7**

**Working conditions for this control:**

Flows up to 30 l/min (7.9 gpm)  
Pressure up to 210 bar (3050 psi)

Electric push-pull control 3 positions  
12 Vdc (coil power 31 Watt at 20°C)

**E8**

**Working conditions for this control:**

Flows up to 30 l/min (7.9 gpm)  
Pressure up to 210 bar (3050 psi)

Electric push-pull control 3 positions  
24 Vdc (coil power 31 Watt at 20°C)

**ELECTRIC  
CONNECTIONS SCHEME**

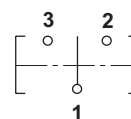

- 1) NEGATIVE POLE
- 2) SPOOL IN
- 3) SPOOL OUT
- 4) GROUND WIRE

Emergency lever for electric  
push-pull control

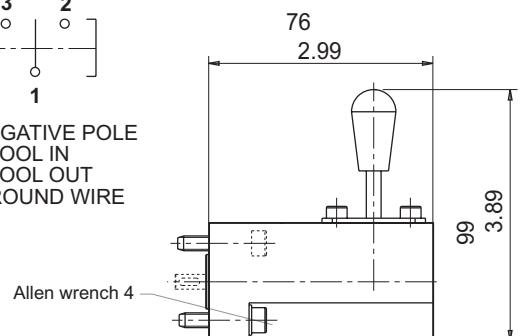

**Important:** this lever was realized as emergency  
lever and it'snot allowed a continuous use.

**IP**

**Important:**  
when you order please specify top or side ports

Hydraulic proportional control

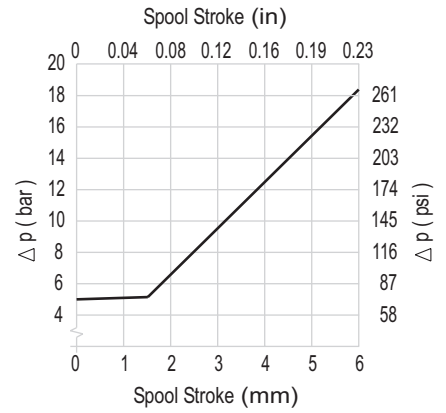
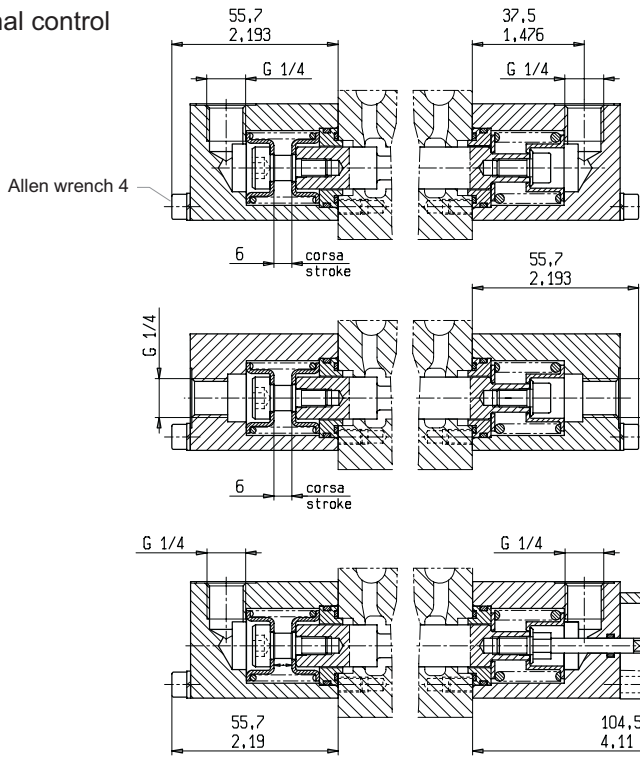
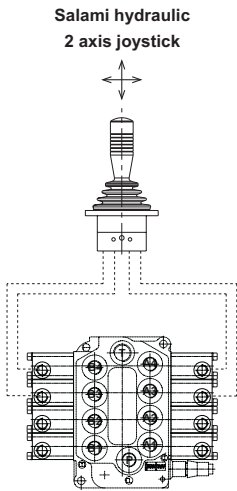
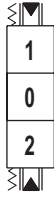

Hydraulic proportional control with emergency lever. Available for q.ty please get in touch with our sales dept.

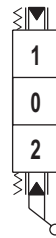

Also available release with emergency lever and microswitch.

**IF**

**XA, XB, XF PORTS : G 1/4**

Hydraulic proportional control with third float position (spool in)

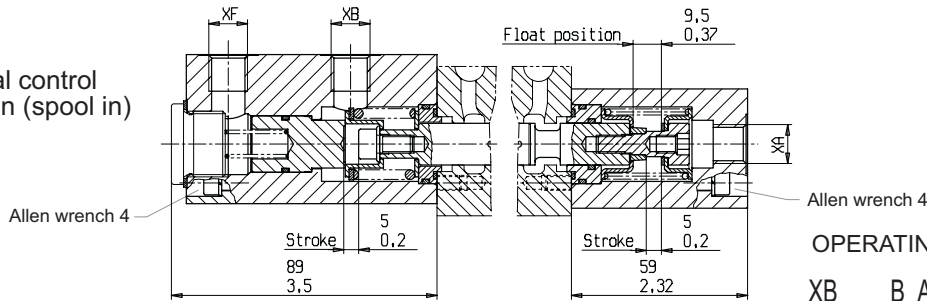

**OPERATING SCHEME**

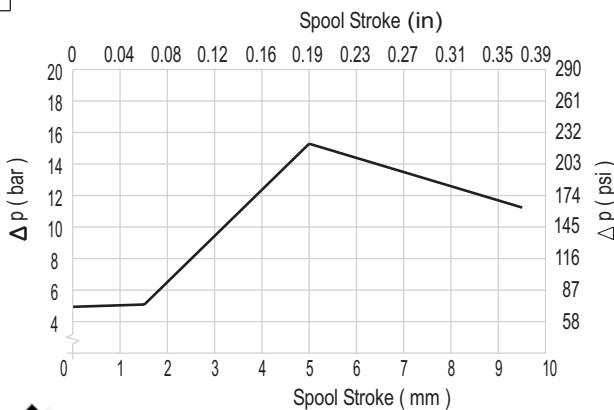
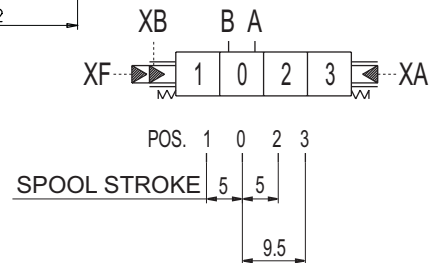

- XA, XB, XF → T ⇨ POS. 0
- Pressure → XB ⇨ POS. 1
- Pressure → XA, XF ⇨ POS. 2
- Pressure → XA ⇨ POS. 3

# DIRECTIONAL CONTROL VALVE MONOBLOCK TYPE

# VDM6

Thought for all truck hydraulic applications

## PP/P0

Pneumatic proportional/on-off control

Available also with ports threaded 1/8 NPT

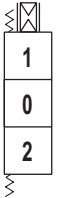
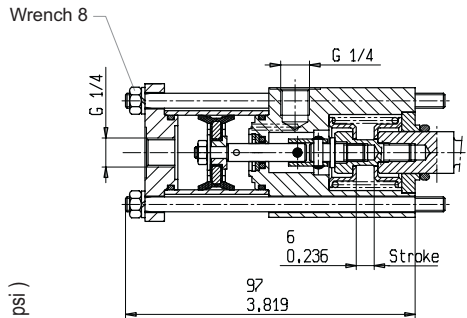
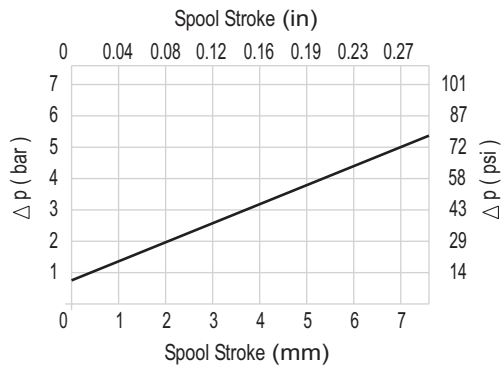

Pneumatic proportional/on-off control  
This control is at the same time proportional and on-off type, it depends if you use a pneumatic remote control proportional type (with the characteristic curve of diagram), or on-off type.



### ELECTRICAL DATA

- VOLTAGE: 12Vdc OR 24Vdc
- COIL POWER: 6 Watt at 20°C
- PROTECTION INDEX WITH CONNECTOR: IP 65

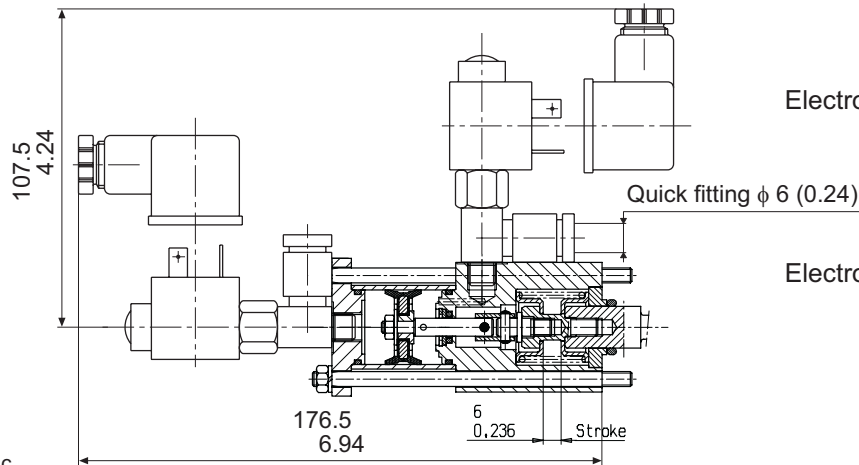

## P1

Electro-pneumatic on-off control - 12 Vdc

## P2

Electro-pneumatic on-off control - 24 Vdc

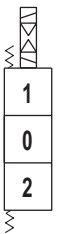

Starting from PP/PO adding the electro-valves you get P1 or P2

### OPERATING SCHEME

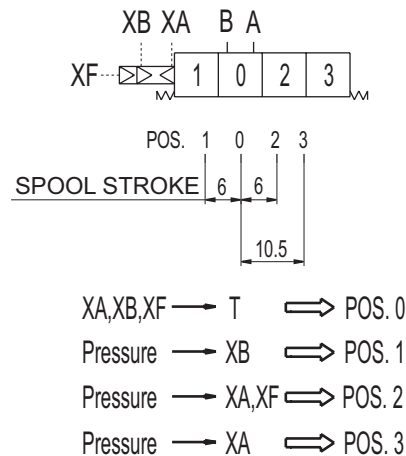

XA, XB, XF PORTS : G 1/4

## PQ

Pneumatic on-off control with third float position (spool in)

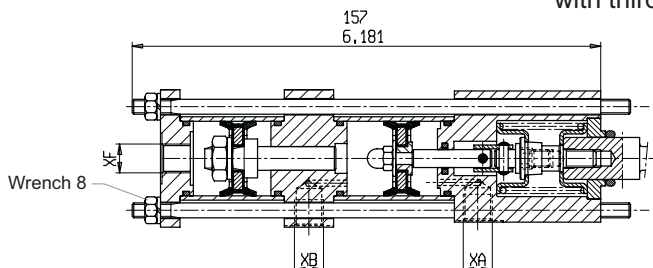

For electro-pneumatic control with third float position, please get in touch with our sales dept.

## SPOOL POSITIONINGS

### C2

Spring centered to neutral position

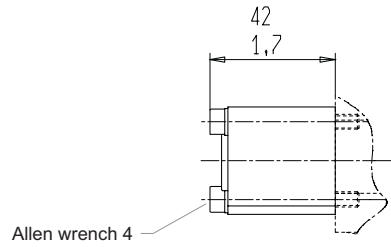
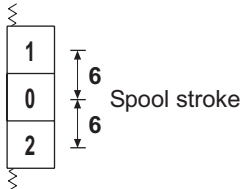

### C6

Two positions (neutral/pos. 1)  
with spring return in neutral

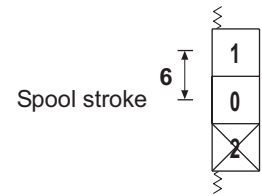

### C5

Two positions (neutral/pos. 2)  
with spring return in neutral

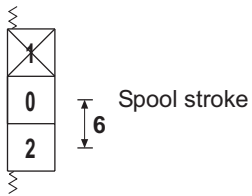

### C3

Spring centered to neutral  
(threaded male pivot  
for remote control)

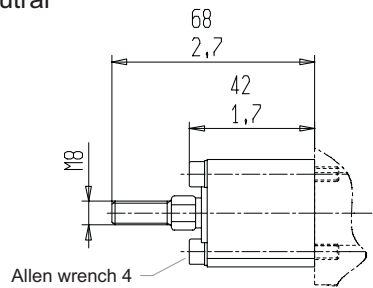
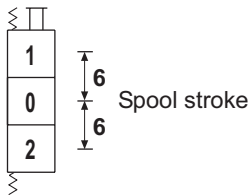

### C4

Spring centered to neutral  
(threaded female pivot  
for remote control)

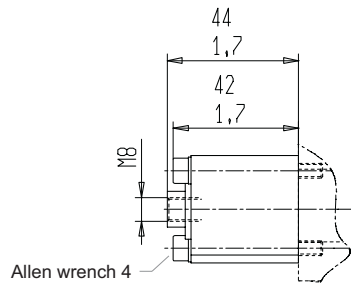
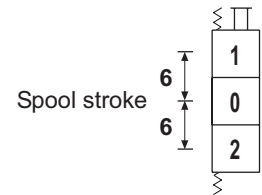

### C7

Two positions (pos. 1/pos. 2)  
with spring return in pos. 1

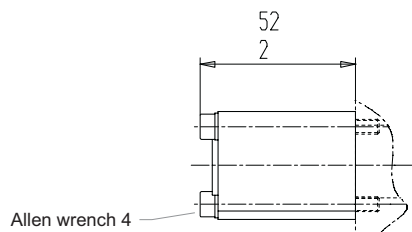
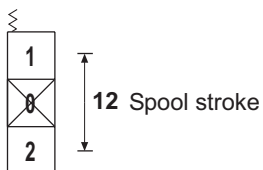

### C8

Two positions (pos1/pos. 2)  
with spring return in pos. 2

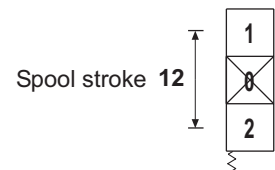

**R2**

Detent on pos. 1/pos. 2  
with spring return in neutral

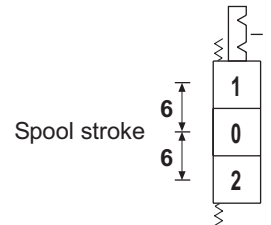

**R5**

Detent on pos. 2  
with spring return in neutral

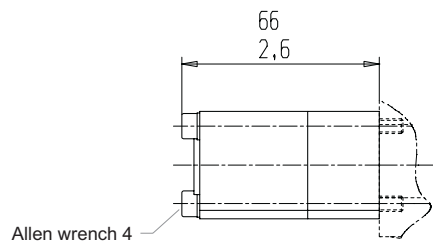
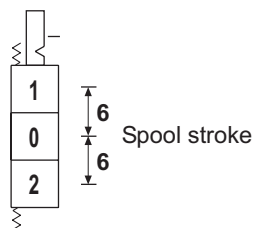

**R4**

Detent on pos. 1  
with spring return in neutral

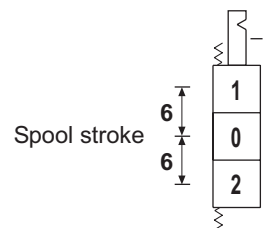

**R6**

Two positions with detent on pos. 2  
with spring return in neutral

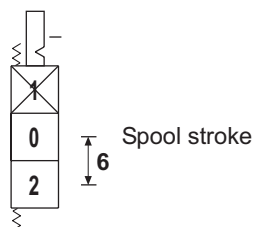

**R7**

Two positions with detent on pos. 1  
with spring return in neutral

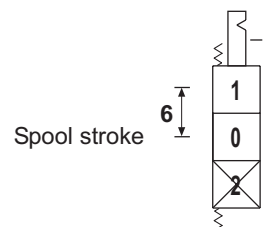

**CO**

Detent on each intermediate positions

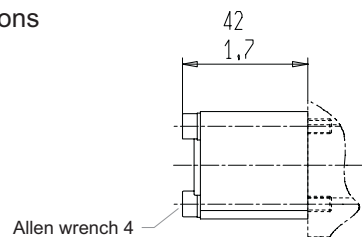
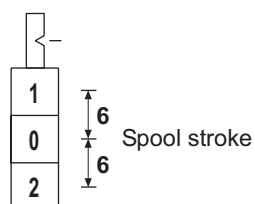

**R9**

Detent on pos. 1/pos. 2  
and neutral position

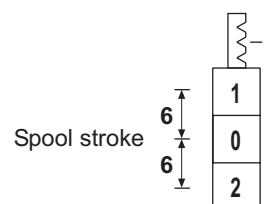

### F1

Detent on pos. 3  
with spring return in neutral

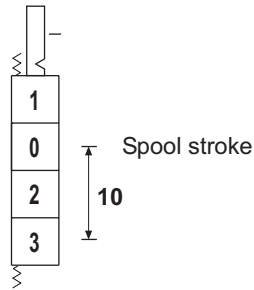

### F2

Detent on pos. 1/pos. 2/pos. 3  
with spring return in neutral

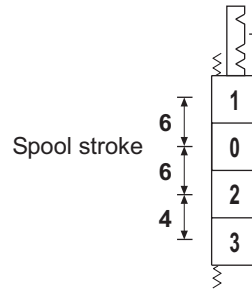

### F3

Detent on pos. 1/pos. 3  
with spring return in neutral

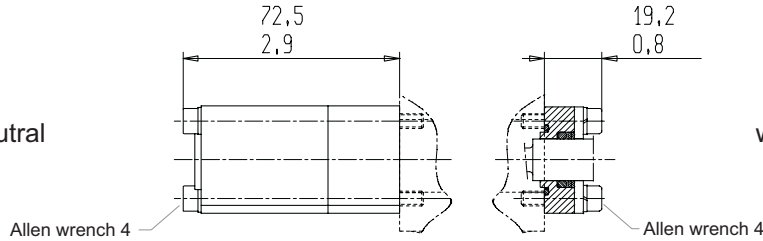
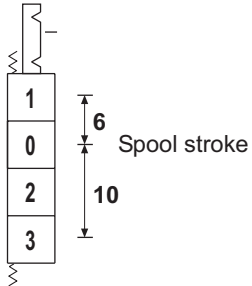

### F4

Detent on pos. 2/pos. 3  
with spring return in neutral

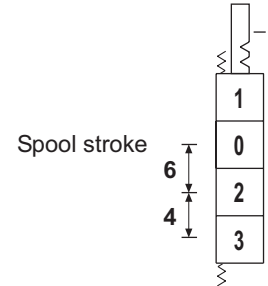

### F5

Detent on pos. 3  
with spring return in neutral

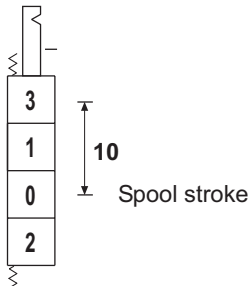

### F6

Detent on pos. 1/pos. 3  
with spring return in neutral

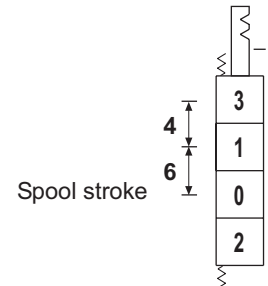

### F7

Detent on pos. 2/pos. 3  
with spring return in neutral

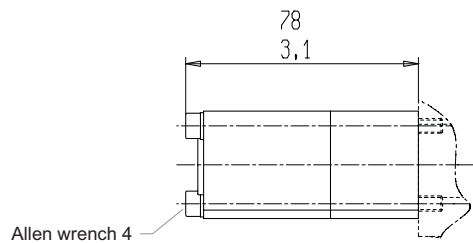
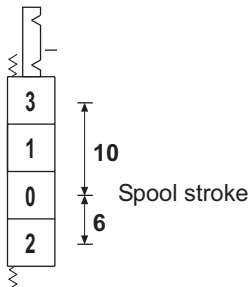

### F8

Detent on pos. 1/pos. 2/pos. 3  
with spring return in neutral

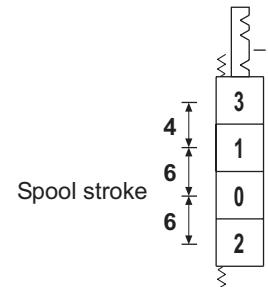



**PM**

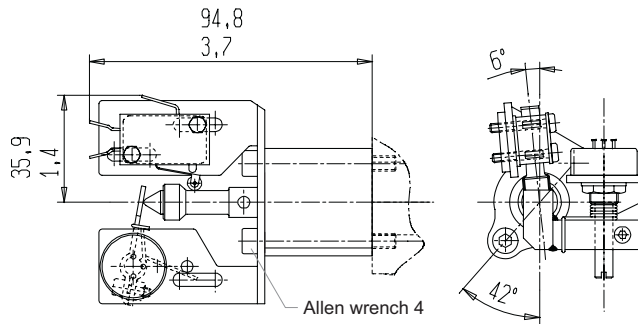

Spool positioning with microswitch to start an electric motor and potentiometer to run up speed motor (available also for single acting spools)

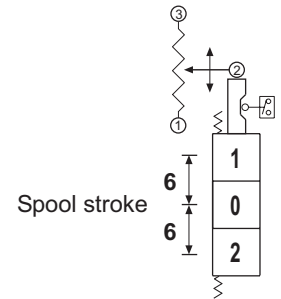
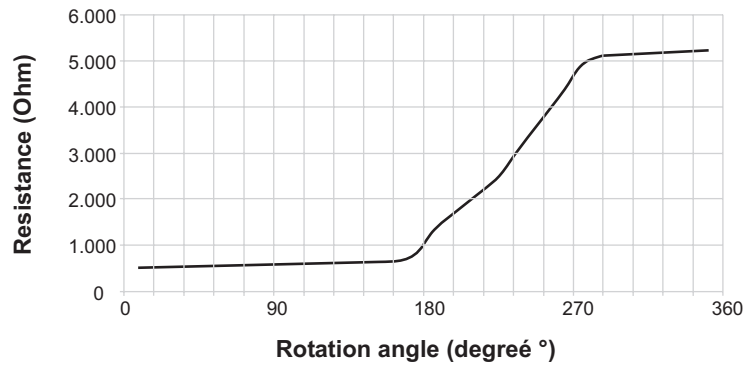

### CE

Pre-arrangement for electrical device

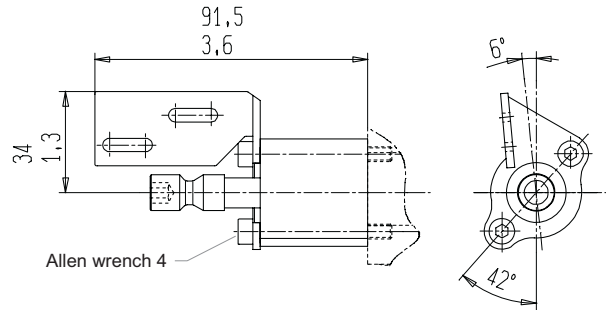
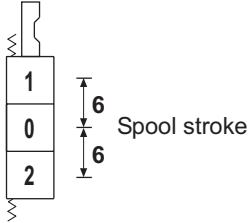

### CM

#### MICROSWITCH TYPE: SAIA - BURGESS XGK - 88

For more information please get in touch with our sales dept.

Spool positioning with microswitch to start an electric motor (available also for single acting spools)

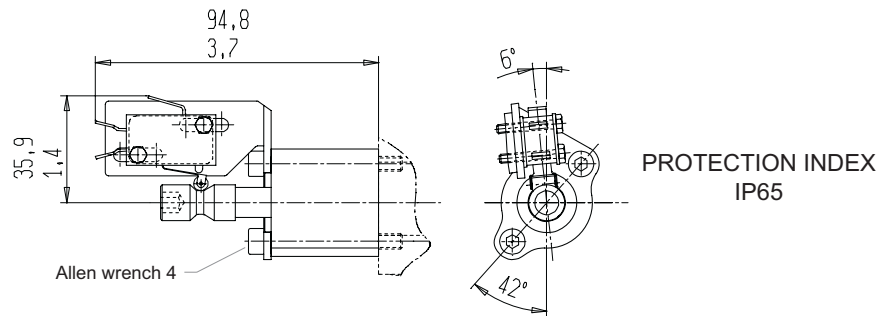
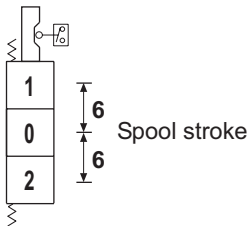

### CW

Spool positioning with waterproof microswitch to start an electric motor (available also for single acting spools)

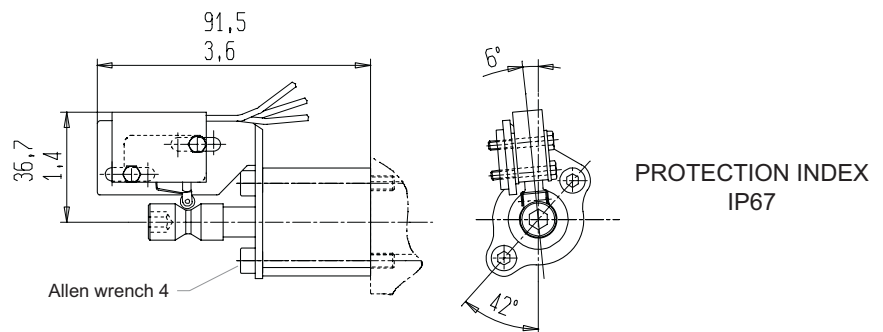
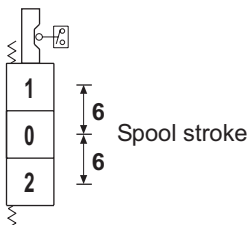

### CD

Spool positioning with double microswitch (available also for single acting spools)

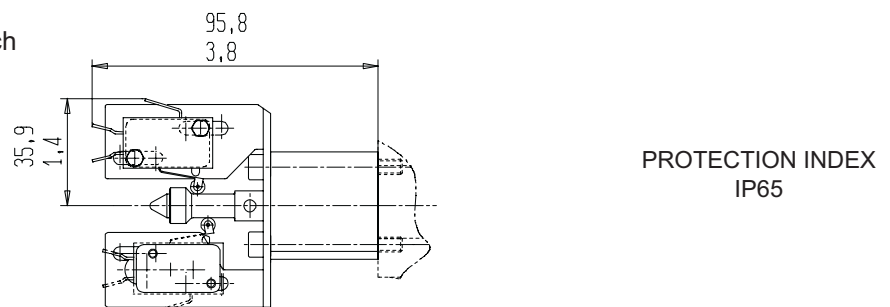
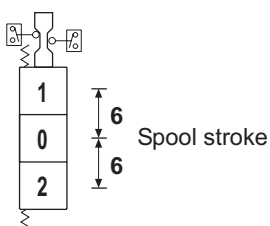

## G2

Detent on pos. 1/pos. 2  
with hydraulic kick-out

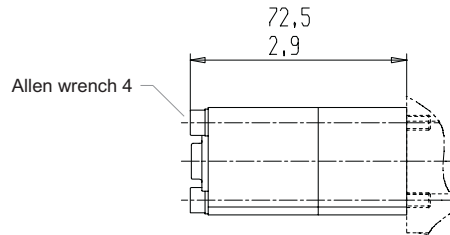
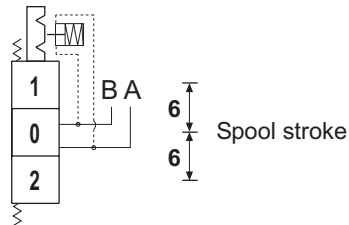

IMPORTANT:

When you order, please specify the setting pressure of the device.  
With this type of spool positioning a special machining of the body is required.

## G5

Detent on pos. 2  
with hydraulic kick-out

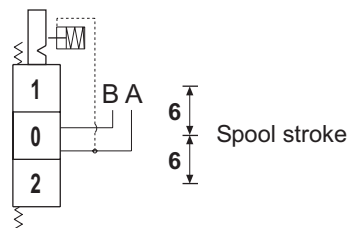

## G4

Detent on pos. 1  
with hydraulic kick-out

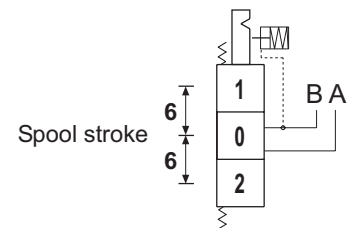

## G6

Detent on pos. 1/pos. 2/pos. 3  
with hydraulic kick-out  
on pos. 1 and pos. 2  
and manual release on pos. 3

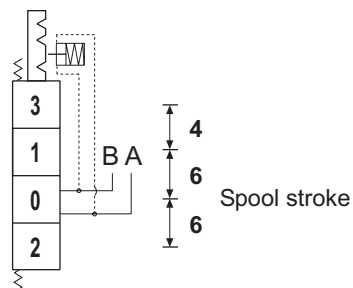

## G8

Detent on pos. 2/pos. 3  
with hydraulic kick-out  
on pos. 2  
and manual release on pos. 3

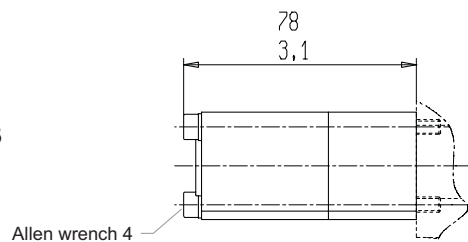
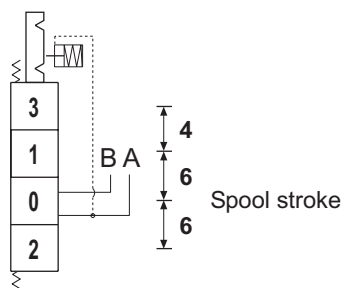

## G7

Detent on pos. 1/pos. 3  
with hydraulic kick-out  
on pos. 1  
and manual release on pos. 3

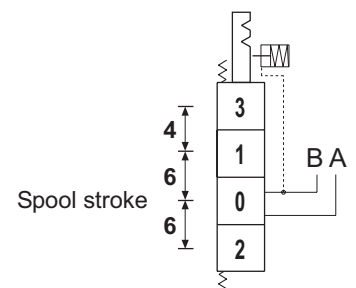

# How to order/VDM6

## DIRECTIONAL CONTROL VALVE MONOBLOCK TYPE

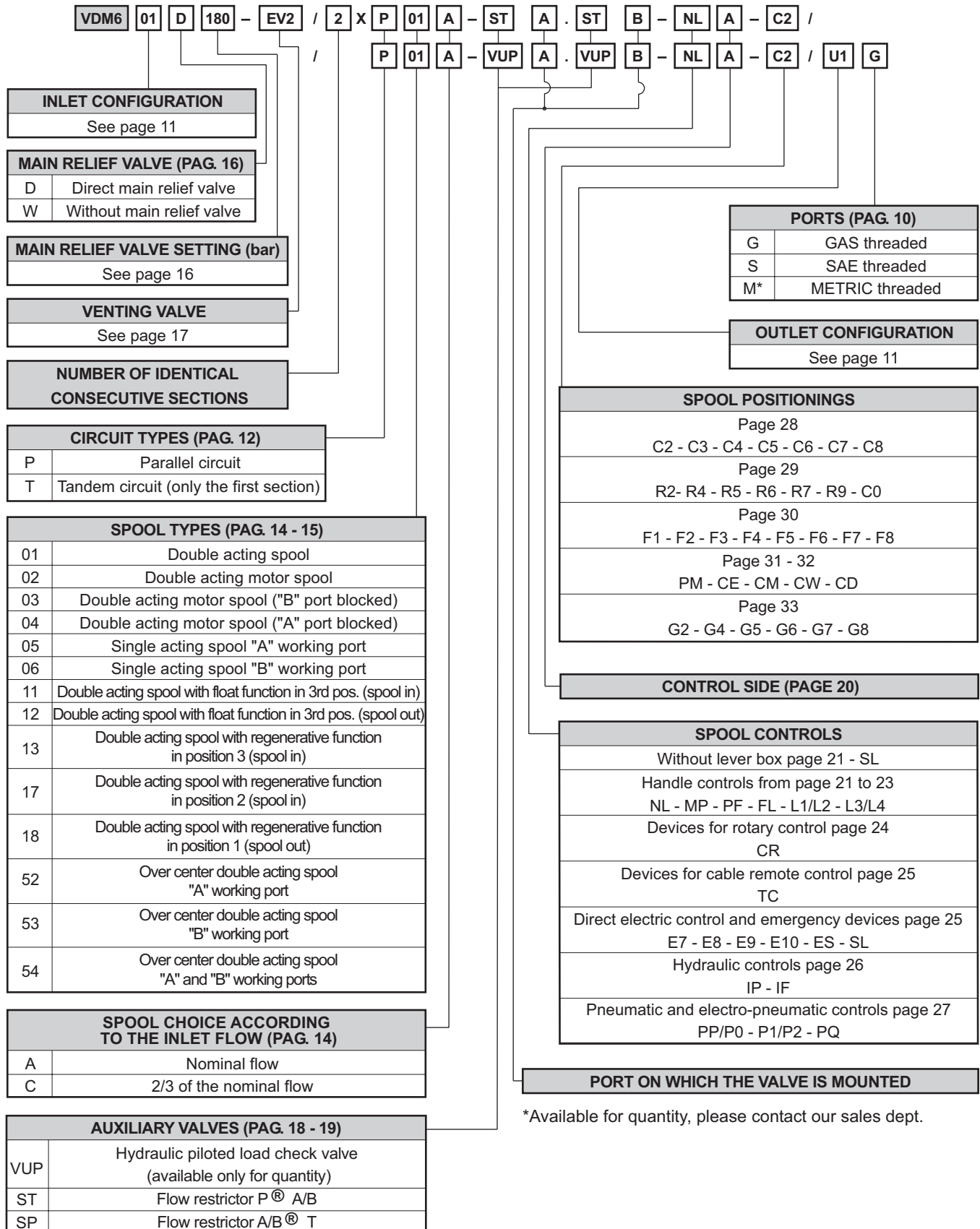

\*Available for quantity, please contact our sales dept.

**DESCRIPTION OF THE NEW PRODUCT IDENTIFICATION LABEL**

Based on the firm certification ISO 9001 - UNI EN 29001, section 4.8 (identification and traceability of the product), we have adopted a new identification label starting from the 1<sup>st</sup> march 1995. Pls, see following example:

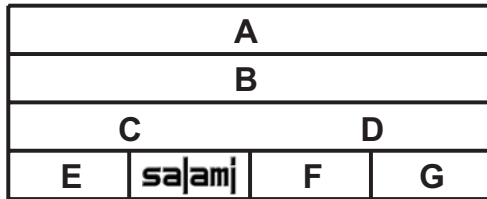

- A = Product short description (eg. VD8A/FDD/U4G).**
- B = Customer part number.**
- C = Salami part number (eg. 6235 0025 0).**
- D = Production code (for Salami management)**
- E = Rotation sense (only for pumps).**
- F = Production date (see data sheet here below)**
- G = Progressive number of assembling.**

Only for pumps 2PB and 2PZ (except triple 2PB) the identification product is marked on the top of the pump body as shown here below:

**SALAMI 09/02**  
**MADE IN ITALY 4010998**  
**612271211 nr. 13**  
**2PB 19S B25 B5**

Product short description. \_\_\_\_\_

Salami part number and progressive number of assembling. \_\_\_\_\_

Production code (for Salami management). \_\_\_\_\_

Month and year of made: maybe in the future you can find this type of production date in the label beside too. \_\_\_\_\_

Rotation sense. \_\_\_\_\_

ASSEMBLED	1997	1998	1999	2000	2001	2002	2003	2004	2005	2006	2007	2008	2009	2010	2011	2012
JANUARY	7A	8M	9M	0M	1M	2M	3M	4M	5M	6M	7M	08M	09M	10M	11M	12M
FEBRUARY	7B	8N	9N	0N	1N	2N	3N	4N	5N	6N	7N	08N	09N	10N	11N	12N
MARCH	7C	8P	9P	0P	1P	2P	3P	4P	5P	6P	7P	08P	09P	10P	11P	12P
APRIL	7D	8Q	9Q	0Q	1Q	2Q	3Q	4Q	5Q	6Q	7Q	08Q	09Q	10Q	11Q	12Q
MAY	7E	8R	9R	0R	1R	2R	3R	4R	5R	6R	7R	08R	09R	10R	11R	12R
JUNE	7F	8S	9S	0S	1S	2S	3S	4S	5S	6S	7S	08S	09S	10S	11S	12S
JULY	7G	8T	9T	0T	1T	2T	3T	4T	5T	6T	7T	08T	09T	10T	11T	12T
AUGUST	7H	8U	9U	0U	1U	2U	3U	4U	5U	6U	7U	08U	09U	10U	11U	12U
SEPTEMBER	7I	8V	9V	0V	1V	2V	3V	4V	5V	6V	7V	08V	09V	10V	11V	12V
OCTOBER	7J	8Z	9Z	0Z	1Z	2Z	3Z	4Z	5Z	6Z	7Z	08Z	09Z	10Z	11Z	12Z
NOVEMBER	7K	8X	9X	0X	1X	2X	3X	4X	5X	6X	7X	08X	09X	10X	11X	12X
DECEMBER	7L	8Y	9Y	0Y	1Y	2Y	3Y	4Y	5Y	6Y	7Y	08Y	09Y	10Y	11Y	12Y

## WARRANTY

- We warrant products sold by us to be free from defects in material and workmanship.
- Our sole obligation to buyer under this warranty is the repair or replacement, at our option, of any products or parts thereof which, under normal use and proper maintenance, have proven defective in material or workmanship, this warranty does not cover ordinary wear and tear, abuse, misuse, averloading, alteration.
- No claims under this warranty will be valid unless buyer notifies SALAMI in writing within a reasonable time of the buyer's discovery of such defects, but in no event later than twelve (12) months from date of shipment to buyer.
- Our obligation under this warranty shall not include any transportation charges or cost of installation, replacement, field repair, or other charges related to returning products to us; or any liability for direct, indirect or consequential damage or delay. If requested by us, products or parts for which a warranty claim is made are to be returned transportation prepaid to our factory. The risk of loss of any products or parts thereof returned to SALAMI will be on buyer.
- No employee or representative is authorized to change any warranty in any way or grant any other warranty unless such change is made in writing and signed by an officer of SALAMI.





SALAMI spa  
via Emilia Ovest 1006  
41100 Modena Italy  
telefono +39-059-387411  
telefax +39-059-387500  
export@salami.it - www.salami.it



SALAMI ITALIA srl  
strada Pelosa 183  
S. Pietro in Trigogna VI Italy  
telefono +39-0444-240080  
telefax +39-0444-240204  
salami.italia@salami.it



SALAMI ESPAÑA  
Poligono Industrial Armenteres  
C/Primer de Maig, 18, Nave 4  
08980 San Feliu de Llobregat  
Barcelona  
telefono +34-93-6327288  
telefax +34-93-6667826  
info@salamispain.com



SALAMI FRANCE  
22, rue Louis Saillant  
69120 Vaulx en Velin  
Lyon  
telefono +33-04-78809941  
telefax +33-04-78803669  
e.pasian@wanadoo.fr



149 S0. Chenango St. Ext.,  
GREEN, NY 13778  
Tel.: +1-607-6565702  
Fax.: +1-607-6565704  
info@salamihydraulics.com