

*Powering Business Worldwide*

# Table of Contents

## Service Parts

Pump Description .....	3
Basic pump	
Pump Operation	
Controls Types	
Part Identification.....	4
PVM 018/020 .....	9
PVM 045/050 .....	14
PVM 057/063 .....	15
PVM 074/081 .....	19
PVM 098/106 .....	24
PVM 131/141 .....	29

## Repair

General Information.....	34
Replacement Parts	
Required Tools	
Special Tools	
Disassembly, Inspection and Assembly .....	35
Disassembly.....	36
Inspection Repair and Replacement .....	40
Assembly .....	42
Testing .....	46
Troubleshooting .....	46
Assembly Torque Values .....	47

# Pump Description

## Basic Pump

Figure 1 shows the basic construction of the PVM series piston pump. Major parts include the 1. Shaft 2. Housing, 3. Swash plate, 4. Rotating group, 5. Valve plate, 6. Control sleeve, 7. Control rod, 8. End Cover, 9. Control 10. Flange

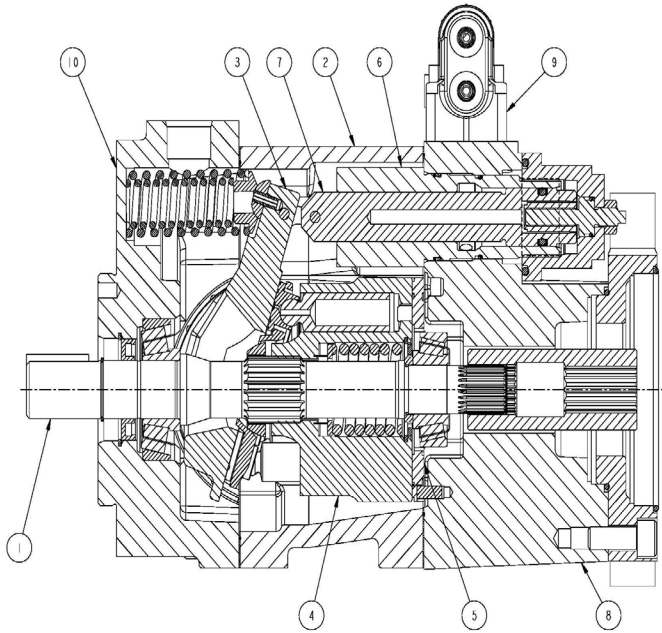

Figure 1

## Pump Operation

In axial piston pumps, the pistons reciprocate parallel to the axis of rotation of the cylinder barrel. The simplest type of axial piston pump is the swash plate in-line design. The cylinder barrel in this pump is turned by the drive shaft. Pistons fitted to bores in the cylinder barrel are connected through piston shoes and a shoe plate, so that the shoes bear against an angled swash plate.

As the barrel turns, the piston shoes follow the swash plate, causing the pistons to reciprocate. The ports are arranged in the valve plate so that the pistons pass the inlet as they are pulled out and pass the outlet as they are forced back in. The displacement of axial piston pumps is determined by the size and number of pistons, as well as the stroke length which is determined by the angle of the swash plate. In variable displacement Models of the in-line pump, the swash plate is installed in a saddle Bearing. "Pivoting" the swash plate in saddle bearings changes the swash plate angle to increase or decrease the piston stroke.

## Pump Controls Types

Three common pump control types are available. One type is the standard "A" compensator control that limits pump outlet pressure to a desired level. The other type is the "B+C" pressure limited/load sensing control. Now available is the "IC" (Industrial Control) which can be used as a load sensing compensator, remote compensator control and electrohydraulic control. These limit pump outlet pressure and also regulate pump displacement to match load requirements. A cold start valve option is also available.

# Identification of Parts

Model PVM018

Model PVM020

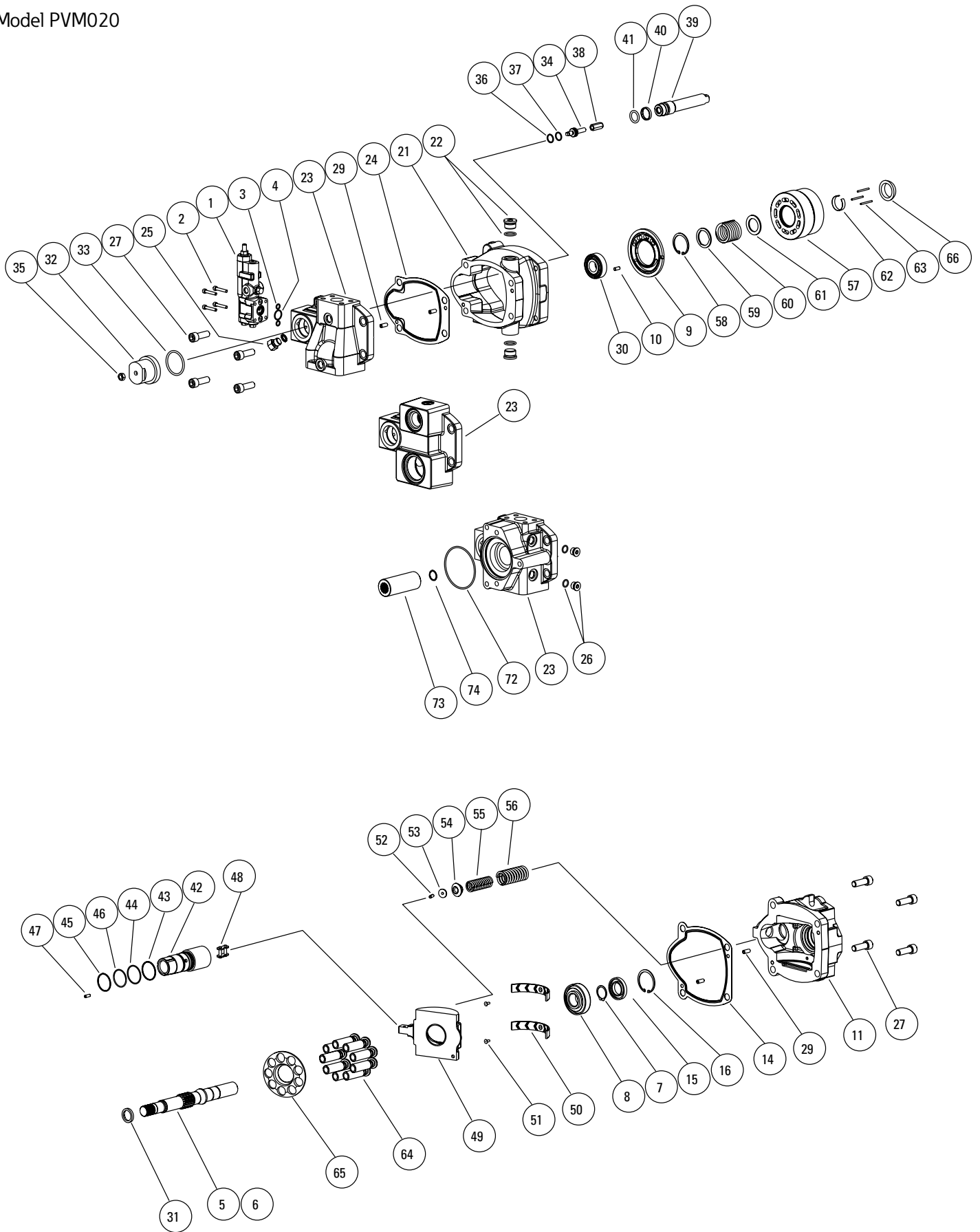

# Parts List

Model PVM018  
Model PVM020

Item	Part No.	Qty.	Note	Description
1	See Table 1	1		Pressure Compensator
2	114953-030	4	A G	Soc HD Cap Screw M5
3	104166-011	2	A B G	O-Ring
4	104166-017	1	A B G	O-Ring
5	See Table 2	1		Drive Shaft
6	See Table 2	1		Key
7	Not Used			Retaining Ring
8	417381	1	E H	Bearing S/A
9	See Table 3	1		Valve Plate
10	16028-303	1		Pin (Valve Plate)
11	See Table 4	1		Mounting Flange
12	Not Used			Soc HD Cap Screw M5
13	Not Used			Soc HD Cap Screw M5
14	943990	1	B	Flange Gasket
15	937340	1	B F	Shaft Seal
16	101680-162	1	B F	Retaining Ring
17	Not Used			Seal Collar
18	Not Used			Retaining Ring
19	Not Used			O-Ring
20	Not Used			Filter
21	See Table 5	1		Housing
22	See Table 5	2		O-Ring Plug S/A
23	See Tables 6&7	1		End Cover
24	937317	1	B	Gasket
25	115046-002	1		O-Ring Plug S/A
26	115046-004	2		O-Ring Plug S/A
27	114976-040	8		Soc HD Cap Screw
28	Not Used			Soc HD Cap Screw
29	16026-608	4		Roll Pin
30	02-335336	1	E	Bearing S/A
31	4992182-xxx	A/R	J	Spacer
32	943933	1		Control Cap
33	115016-221	1	B	O-Ring
34	997089	1		Adjustment Screw
35	4992732-001	1		Jam Nut
36	8770-015	1	B	Back-Up Ring
37	104166-015	1	B	O-Ring
38	943934	1		Adjustment Sleeve
39	943931	1		Control Piston
40	937455	1	B	Glide Ring
41	104166-110	1	B	O-Ring
42	943932	1		Sleeve
43	115001-023	1	B	Back-Up Ring
44	104166-023	1	B	O-Ring
45	115001-022	1	B	Back-Up Ring

Item	Part No.	Qty.	Note	Description
46	104166-022	1	B	O-Ring
47	16028-303	1		Pin
48	932921	1	M	Chain Link
49	943992	1		Swashplate
50	02-340318	2	D	Cradle Bearing S/A
51	Not Used			Screw Socket Flat Head
52	16026-608	1	D	Pin
53	409998	1	D	Button
54	409999	1	D	Spring Seat
55	Not Used			Inner Bias Spring
56	943905	1		Outer Bias Spring
57	937061	1	C	Cylinder Barrel (018)
57	937062	1	C K	Cylinder Barrel (020)
58	101680-145	1	C L	Retaining Ring
59	937338	1	C	Spring Guide, Outer
60	937336	1	C	Spring
61	937337	1	C	Spring Guide, Inner
62	913833	1	C	Pin Retainer
63	937339	3	C	Pin
64	02-334516	9	C K	Piston Shoe S/A (018)
64	02-335670	9	C L	Piston Shoe S/A (020)
65	937069	1	C	Shoe Retainer
66	937070	1	C	Ballguide
67	Not Used			Spacer
68	Not Used			Screw
69	Not Used			Adapter
70	Not Used			Screw
71	Not Used			O-Ring, Adapter
72	104166-152	1	B	O-Ring, End Cover
73	See Table 8	1		Coupling
74	See Table 8	1		Retaining Ring

A Available in control kit. See Table 1.

B Available in seal kit 02-347284.

C Available in rotating group kit 02-347285 for PVM018 or rotating group kit 02-347286 for PVM020.

D Available in yoke and saddle bearing kit 02-347287.

E Available in shaft bearing kit 02-347288.

F Available in single shaft seal kit 02-347290. Equivalent double shaft seal kit 02-347291.

G Available in control mounting kit 9900104-000.

H Seat bearing cone against shoulder.

J Use spacers to shim as required to obtain 0,01 to 0,10 mm (0.00039 to 0.0039 in.) axial shaft end play.

K For PVM018 only.

L For PVM020 only.

M Warning: Use Vickers authorized chain link only. Cotter pins on industry standard chain link will fail.

# Parts Tables 1-8

Model PVM018

Model PVM020

**Table 1 – Pressure Compensator**

	Model Code Position		①
	13, 14	17, 18, 19, 20, 21	
SAE Port	All	A2800	114969-001
	All	A0700	114969-002
	01/02	B2811	114970-001
	01/02	C2811	114970-002
	01/02	B2824	114970-003
	01/02	C2824	114970-004
	01/02	B0711	114970-005
	01/02	C0711	114970-006
	01/02	B0724	114970-007
	01/02	C0724	114970-008
Metric Port	03/04	B2811	114970-009
	03/04	C2811	114970-010
	03/04	B2824	114970-011
	03/04	C2824	114970-012
	03/04	B0711	114970-013
	03/04	C0711	114970-014
	03/04	B0724	114970-015
BSPP Port	05	B2811	114970-017
	05	C2811	114970-018
	05	B2824	114970-019
	05	C2824	114970-020
	05	B0711	114970-021
	05	C0711	114970-022
	05	B0724	114970-023
	05	C0724	114970-024

**Table 3 – Industrial Valve Plate**

Model Code Position			⑨
	4, 5, 6	7, 8	
018	ER	937158	
018	MR	937159	
018	EL	937160	
018	ML	937161	
020	ER	937412	
020	MR	937411	
020	EL	937412	
020	ML	937414	

**Table 2 – Shaft and Key and Retaining Ring**

Model Code Position				⑤	⑥
	9, 10	11	25		
05	C	O		937445	4992730-001
06	C	O		937446	4992730-002
07	C	O		937447	–
08	C	O		937448	–
15	B	O		937456	4992728-001
17	D	O		937088	4992728-002
01	A	O		937183	4992730-006
02	A	O		937184	4992730-007
03	B/C	O		937185	–
04	A/B/C	O		937186	–
05	C	A		937449	4992730-001
06	C	A		937450	4992730-003
07	C	A		937451	4992728-002
08	C	A		937452	–
20	C	O		943941	–
16	B	O		996833	4992728-003
17	D	O		996834	–

**Table 4 – Mounting Flange**

Model Code Position				⑪
	11	13, 14	15, 16	
A	01/02	00/AA/AC		943994
A	01/02	AB/AD		937441
A	03/04	00/AA/AC		997020
A	03/04	AB/AD		997021
A	05	00/AA/AC		996928
A	05	AB/AD		996930
B	03/04	00/AA/AC		937442
B	03/04	AB/AD		937443
B	05	00/AA/AC		996929
B	05	AB/AD		996931
C	01/02	00/AA/AC		937429
C	01/02	AB/AD		944105
C	03/04	00/AA/AC		944105
C	03/04	AB/AD		937429
C	05	00/AA/AC		996932
C	05	AB/AD		996934
D	01/02	00/AA/AC		937430
D	01/02	AB/AD		937431
D	03/04	00/AA/AC		–
D	03/04	AB/AD		–
D	05	00/AA/AC		996933
D	05	AB/AD		996935

# Parts Tables 1-8

Model PVM018

Model PVM020

**Table 5 – Housing and Port Plugs**

<b>Model Code Position</b> <b>13, 14</b>	<b>21</b>	<b>22</b>
02	943989	115046-008
01	943989	115046-008
04	937164	115050-018
03	937164	115050-018
05	937165	4992947-001

**Table 7 – End Cover (Thru Drive)**

<b>Model Code Position</b>			<b>23</b>
<b>8</b>	<b>13, 14</b>	<b>25</b>	
R	01	A/B	937460
R	02	A/B	937187
R	03	A/B	937461
R	04	A/B	937188
R	05	A/B	937462
R	03	G/H	937463
R	04	G/H	937189
R	05	G/H	937464
L	01	A/B	996816
L	02	A/B	996819
L	03	A/B	996817
L	04	A/B	996820
L	05	A/B	996822
L	03	G/H	996818
L	04	G/H	996821
L	05	G/H	996823

## Torque Values

<b>Item</b>	<b>Torque Values</b>
2	7,4-9 Nm (65-80 in-lb)
22	95-108 Nm (70-80 ft-lb)
25	3.4-4.5 Nm (30.1-39.8 lbf-in)
26	23-25,8 Nm (17-19 ft-lb)
27	63-77 Nm (46-57 ft-lb)
32	210-230 Nm (155-170 ft-lb)
35	18-24 Nm (13-18 ft-lb)

**Table 6 – End Cover (Non Thru Drive)**

<b>Model Code Position</b>			<b>23</b>
<b>8</b>	<b>12, 13, 14</b>		
R	S01		937150
R	S02		937435
L	S01		937421
L	S02		937438
R	S03		937151
R	S04		937436
L	S03		937437
L	S04		937439
R	E01		937304
R	E02		937306
L	E01		944173
L	E02		937192
R	E03		937305
R	E04		937307
L	E03		937191
L	E04		937194
R	S05		937052
R	E05		937308
L	S05		937940
L	E05		944170

**Table 8 – Coupling (Thru Drive) and Retaining Ring**

<b>Model Code Position</b>		<b>73</b>	<b>74</b>
<b>25</b>	<b>Ref</b>		
A	A9	937454	101680-062
B	A11	937453	101680-062
C	B13	–	–
D	B15	–	–
G	MA9	937454	101680-062
H	MA11	937453	101680-062
J	MB13	–	–

# Identification of Model Code

Model PVM018

Model PVM020

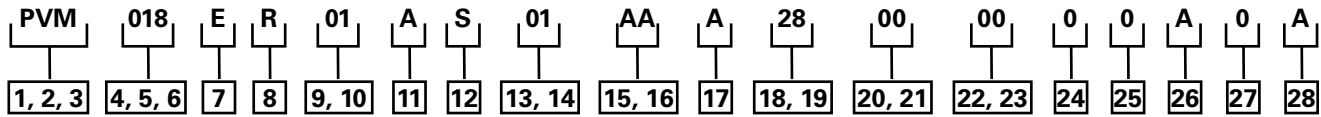

## **1, 2, 3** Pump Series

PVM M-Series variable piston pump

## **4, 5, 6** Displacement

018 18.0 cm<sup>3</sup>/rev (1.10 in<sup>3</sup>/rev)  
280 bar  
020 21.1 cm<sup>3</sup>/rev (1.24 in<sup>3</sup>/rev)  
230 bar

## **7** Valve Plate

**E** - Industrial (1800 rpm max)  
**M** - Mobile equipment speeds

## **8** Input Rotation

**R** - Clockwise (righthand)  
**L** - Counterclockwise (lefthand)

## **9, 10** Input Shaft

01 SAE J744-16-1 A straight key  
02 SAE J744-19-1 19mm straight key  
03 SAE J744-16-4 A 9T spline  
04 SAE J744-16-4 A 11T spline  
05 SAE J744-22-1 B straight key  
06 SAE J744-25-1 B-B straight key  
07 SAE J744-22-4 B 13T spline  
08 SAE J744-25-4 B-B 15T spline

## **11** Mounting Flange

A SAE J744-82-2 (SAE A 2 bolt)  
C SAE J744-101-2 (SAE B 2 bolt)

## **12** Main Port Location

S Side  
E End (na on thru drive)

## **13, 14** Main Port Type

01 SAE J514 tube ports  
02 SAE J518 flange ports  
03 ISO 6149-1 tube ports  
04 ISO 6162 flange ports

## **15, 16** Pump Special Features

00 None (single shaft seal)  
AA Adjustable maximum displacement stop and single shaft seal (standard)  
AB Double shaft seal, two way  
AD Adjustable maximum displacement stop and double shaft seal

## **17** Control

0 None  
A Pressure compensator  
B Pressure and flow compensator with bleed orifice  
C Pressure and flow compensator with plugged orifice

## **18, 19** Pressure Comp Setting

00 None  
07 66-74 bar (957-1073 psi)  
23 227-234 bar (3277-3393 psi) 020 cm<sup>3</sup>/rev  
28 276-284 bar (4002-4118 psi) 018 cm<sup>3</sup>/rev

## **20, 21** Flow Comp Setting

00 None  
11 10-11 bar (145-174 psi)  
20 19-21 bar (275.5-304.5 psi)  
24 23-25 bar (333.5-362.5 psi)

## **22, 23** Torque Limiter Setting

00 None

## **24** Compensator Special Features

0 None

## **25** Auxiliary Mounting Pad

0 None  
A SAE A 2 bolt 9T spline  
B SAE A 2 bolt 11T spline

## **26** Paint

0 No paint  
A Blue (standard)

## **27** Customer Identification

0 None

## **28** Design Code

A A (initial release)



# Identification of Parts

Model PVM045

Model PVM050

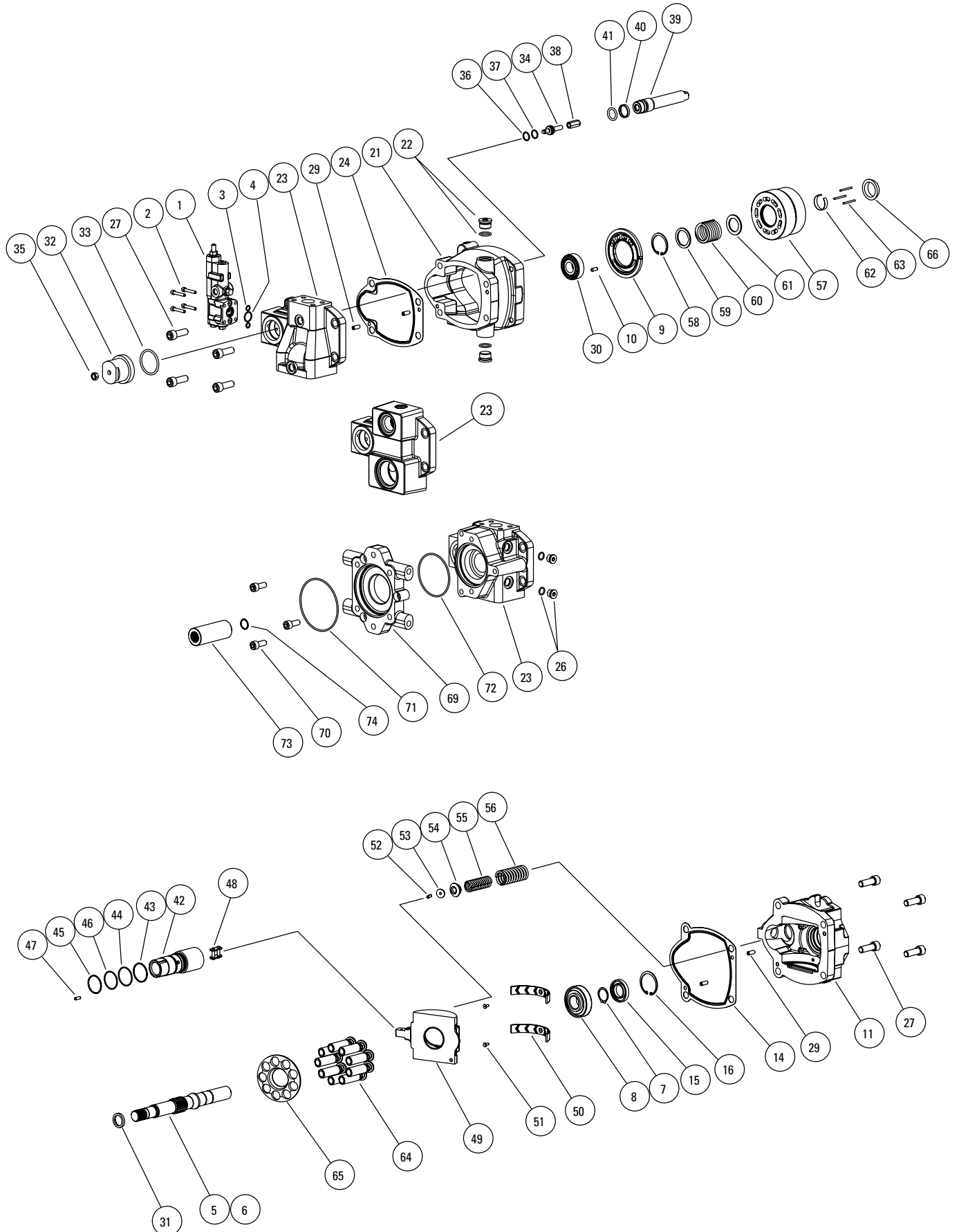

# Parts List

Model PVM045

Model PVM050

Item	Part No.	Qty.	Note	Description
1	See Table 1	1		Pressure Compensator
2	114953-030	4	A G	Soc HD Cap Screw M5
3	104166-011	2	A B G	O-Ring
4	104166-017	1	A B G	O-Ring
5	See Table 2	1		Drive Shaft
6	See Table 2	1		Key
7	See Table 2	1		Retaining Ring
8	419627	1	E H	Bearing S/A
9	See Table 3	1		Valve Plate
10	114997-004	1		Pin (Valve Plate)
11	See Table 4	1		Mounting Flange
12	Not Used			Soc HD Cap Screw M5
13	Not Used			Soc HD Cap Screw M5
14	932915	1	B	Flange Gasket
15	626933	1	B F	Shaft Seal
16	101680-175	1	B F	Retaining Ring
17	Not Used			Seal Collar
18	Not Used			Retaining Ring
19	Not Used			O-Ring
20	Not Used			Filter
21	See Table 5	1		Housing
22	See Table 5	2		O-Ring Plug S/A
23	See Tables 6&7	1		End Cover
24	932916	1	B	Gasket
25	Not Used			O-Ring Plug S/A
26	See Tables 6&7	2		O-Ring Plug S/A
27	114977-035	8		Soc HD Cap Screw
28	Not Used			Soc HD Cap Screw
29	96201-062	4		Roll Pin
30	473914	1	E	Bearing S/A
31	4992184-xxx	A/R	J	Spacer
32	934286	1		Control Cap
33	115016-224	1	B	O-Ring
34	934287	1		Adjustment Screw
35	4992732-001	1		Jam Nut
36	8770-015	1	B	Back-Up Ring
37	104166-015	1	B	O-Ring
38	934340	1		Hex Stop
39	932919	1		Control Piston
40	932924	1	B	Glide Ring
41	104166-210	1	B	O-Ring
42	932920	1		Sleeve
43	114998-028	1	B	Back-Up Ring
44	104166-028	1	B	O-Ring
45	114998-027	1	B	Back-Up Ring

Item	Part No.	Qty.	Note	Description
46	104166-027	1	B	O-Ring
47	95902-050	1		Pin
48	932921	1	M	Chain Link
49	932918	1		Swashplate
50	937055	2	D	Cradle Bearing
51	114995-010	2	D	Screw Socket Flat Head
52	16026-608	1	D	Pin
53	409998	1	D	Button
54	934189	1	D	Spring Seat
55	932928	1		Inner Bias Spring
56	932929	1		Outer Bias Spring
57	933028	1	C K	Cylinder Barrel (045)
57	932930	1	C L	Cylinder Barrel (050)
58	101680-162	1	C	Retaining Ring
59	423368	1	C	Spring Guide, Outer
60	402579	1	C	Spring
61	404932	1	C	Spring Guide, Inner
62	410050	1	C	Pin Retainer
63	114996-006	3	C	Pin
64	415621	9	C K	Piston Shoe S/A (045)
64	02-328123	9	C L	Piston Shoe S/A (050)
65	402650	1	C	Shoe Retainer
66	402580	1	C	Ballguide
67	Not Used			Spacer
68	Not Used			Screw
69	See Table 7	1		Adapter
70	114976-025	3		Screw
71	104166-155	1	B	O-Ring, Adapter
72	104166-152	1	B	O-Ring, End Cover
73	See Table 8	1		Coupling
74	See Table 8	1		Retaining Ring

A Available in control kit. See Table 1.

B Available in seal kit 02-346161.

C Available in rotating group kit 02-346162 for PVM045 or rotating group kit 02-346172 for PVM050.

D Available in yoke and saddle bearing kit 02-346163.

E Available in shaft bearing kit 02-346164.

F Available in single shaft seal kit 02-346166. Equivalent double shaft seal kit 02-346167.

G Available in control mounting kit 9900104-000.

H Seat bearing cone against shoulder.

J Use spacers to shim as required to obtain 0,01 to 0,10 mm (0.00039 to 0.0039 in.) axial shaft end play.

K For PVM045 only.

L For PVM050 only.

M Warning: Use Vickers authorized chain link only. Cotter pins on industry standard chain link will fail.

# Parts Tables 1 - 8

Model PVM045

Model PVM050

**Table 1 – Pressure Compensator**

	<b>Model Code Position</b>		<b>1</b>
	<b>13, 14</b>	<b>17, 18, 19, 20, 21</b>	
<b>SAE Port</b>	All	A2800	02-345631
	All	A0700	02-345629
	01/02	B2811	02-345594
	01/02	C2811	02-345596
	01/02	B2824	02-345598
	01/02	C2824	02-345600
	01/02	B0711	02-345601
	01/02	C0711	02-345602
	01/02	B0724	02-345603
	01/02	C0724	02-345604
<b>Metric Port</b>	03/04	B2811	02-345606
	03/04	C2811	02-345608
	03/04	B2824	02-345610
	03/04	C2824	02-345612
	03/04	B0711	02-345613
	03/04	C0711	02-345614
	03/04	B0724	02-345615
<b>BSPP Port</b>	05	B2811	02-345618
	05	C2811	02-345620
	05	B2824	02-345622
	05	C2824	02-345624
	05	B0711	02-345625
	05	C0711	02-345626
	05	B0724	02-345627
	05	C0724	02-345628

**Table 2 – Shaft, Key and Retaining Ring**

	<b>Model Code Position</b>			<b>5</b>	<b>6</b>	<b>7</b>
	<b>9, 10</b>	<b>11</b>	<b>26</b>			
05	C	O		934380	22971	–
06	C	O		934381	58303	96098-100
07	C	O		934382	–	–
08	C	O		932927	–	–
05	C	A/B/G/H		934391	22971	–
06	C	A/B/G/H		934392	58303	96098-100
07	C	A/B/G/H		934393	–	–
08	C	A/B/G/H		934394	–	–

**Table 3 – Industrial Valve Plate**

	<b>Model Code Position</b>		<b>9</b>
	<b>4, 5, 6</b>	<b>7, 8</b>	
045	ER		932922
045	MR		932925
045	EL		934275
045	ML		934276
050	ER		934280
050	MR		933027
050	EL		934278
050	ML		934277

**Table 4 – Mounting Flange**

	<b>Model Code Position</b>			<b>11</b>
	<b>11</b>	<b>13, 14</b>	<b>15, 16</b>	
C	01/02	00/AA/AC		932914
C	01/02	AB/AD		934397
C	03/04	00/AA/AC		943776
C	03/04	AB/AD		943775
C	05	00/AA/AC		934399
C	05	AB/AD		934400
D	01/02	00/AA/AC		943821
D	01/02	AB/AD		943822
D	03/04	00/AA/AC		943274
D	03/04	AB/AD		934398
D	05	00/AA/AC		943773
D	05	AB/AD		943774

**Table 5 – Housing and Drain Plugs S/A**

	<b>Model Code Position</b>		<b>21</b>	<b>22</b>
	<b>13, 14</b>			
02			932912	–
01			932912	–
04			934273	–
03			934273	–
05			934401	49929447-001

# Parts Tables 1 - 8

Model PVM045

Model PVM050

**Table 6 – End Cover (Non Thru Drive) and Gauge Port Plug**

Model Code Position		23	26
8	12, 13, 14		
R	S01	934254	115046-006
R	S02	932909	115046-006
L	S01	934257	115046-006
L	S02	934261	115046-006
R	S03	934255	115050-022
R	S04	934259	115050-022
L	S03	934258	115050-022
L	S04	934262	115050-022
R	E01	934355	115046-006
R	E02	934264	115046-006
L	E01	934367	115046-006
L	E02	934267	115046-006
R	E03	934357	115050-022
R	E04	934263	115050-022
L	E03	934369	115050-022
L	E04	934268	115050-022
R	S05	934360	4992947-002
R	E05	934361	4992947-002
L	S05	934373	4992947-002
L	E05	934374	4992947-002

**Table 8 – Coupling (Thru Drive) and Retaining Ring**

Model Code Position		73	74
25	Ref		
A	A9	937238	-
B	A11	937236	-
C	B13	937237	115015-078
D	B15	943792	115015-078
G	MA9	937238	-
H	MA11	937236	-
J	MB13	937237	115015-078
K	MB15	943792	115015-078

**Table 7 – End Cover (Thru Drive), Gauge Port Plug and Adapter**

Model Code Position			23	26	69
8	13, 14	25			
R	01	A/B	934301	115046-006	-
R	02	A/B	934238	115046-006	-
R	03	A/B	934359	115050-022	-
R	04	A/B	934269	115050-022	-
R	05	A/B	934363	4992947-002	-
R	03	G/H	934365	115050-022	-
R	04	G/H	934364	115050-022	-
R	05	G/H	934366	4992947-002	-
R	01	C/D	934301	115046-006	934294
R	02	C/D	934238	115046-006	934294
R	03	C/D	934359	115050-022	934294
R	04	C/D	934269	115050-022	934294
R	05	C/D	934363	4992947-002	934294
R	03	J/K	934365	115050-022	934402
R	04	J/K	934364	115050-022	934402
R	05	J/K	934366	4992947-002	934402
L	01	A/B	934370	115046-006	-
L	02	A/B	934271	115046-006	-
L	03	A/B	934372	115050-022	-
L	04	A/B	934272	115050-022	-
L	05	A/B	934375	4992947-002	-
L	03	G/H	934377	115050-022	-
L	04	G/H	934376	115050-022	-
L	05	G/H	934378	4992947-002	-
L	01	C/D	934370	115046-006	934294
L	02	C/D	934271	115046-006	934294
L	03	C/D	934372	115050-022	934294
L	04	C/D	934272	115050-022	934294
L	05	C/D	934375	4992947-002	934294
L	03	J/K	934377	115050-022	934402
L	04	J/K	934376	115050-022	934402
L	05	J/K	934378	4992947-002	934402

## Torque Values

Item	Torque Values
2	7,4-9 Nm (65-80 in-lb)
22	95-108 Nm (70-80 ft-lb)
26	23-25,8 Nm (17-19 ft-lb)
27	63-77 Nm (46-57 ft-lb)
32	210-230 Nm (155-170 ft-lb)
35	18-24 Nm (13-18 ft-lb)
51	3,6-4,4 Nm (32-39 in-lb)
70	42-50 Nm (31-36,8 ft-lb)

# Identification of Model Code

Model PVM045

Model PVM050

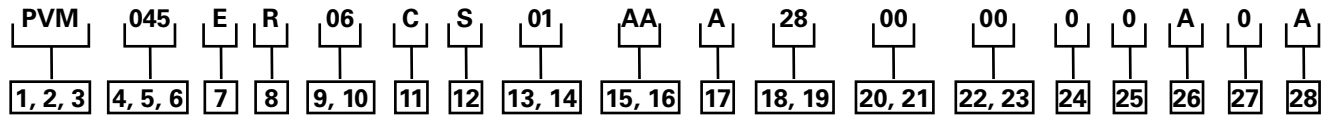

## **1, 2, 3** Pump Series

PVM M-Series variable piston pump

## **4, 5, 6** Displacement

045 45.1 cm<sup>3</sup>/rev (2.75 in<sup>3</sup>/rev) 280 bar

050 50.0 cm<sup>3</sup>/rev (3.00 in<sup>3</sup>/rev) 230 bar

## **7** Valve Plate

**E** - Industrial (1800 rpm max)

**M** - Mobile equipment speeds

## **8** Input Rotation

**R** - Clockwise (righthand)

**L** - Counterclockwise (lefthand)

## **9, 10** Input Shaft

05 SAE J744-22-1 B straight key

06 SAE J744-25-1 B-B straight key

07 SAE J744-22-4 B 13T spline

08 SAE J744-25-4 B-B 15T spline

## **11** Mounting Flange

C SAE J744-101-2 (SAE B 2 bolt)

## **12** Main Port Location

S Side

E End (na on thru drive)

## **13, 14** Main Port Type

01 SAE J514 tube ports

02 SAE J518 flange ports

03 ISO 6149-1 tube ports

04 ISO 6162 flange ports

## **15, 16** Pump Special Features

00 None (single shaft seal)

AA Adjustable maximum displacement stop and single shaft seal (standard)

AB Double shaft seal, two way

AD Adjustable maximum displacement stop and double shaft seal

## **17** Control

0 None

A Pressure compensator

B Pressure and flow compensator with bleed orifice

C Pressure and flow compensator with plugged orifice

## **18, 19** Pressure Comp Setting

00 None

07 66-74 bar (957-1073 psi)

23 227-234 bar (3277-3393 psi) 050 cm<sup>3</sup>/rev

28 276-284 bar (4002-4118 psi) 045 cm<sup>3</sup>/rev

## **22, 23** Torque Limiter Setting

00 None

## **24** Compensator Special Features

0 None

## **25** Auxiliary Mounting Pad

0 None

A SAE A 2 bolt 9T spline

B SAE A 2 bolt 11T spline

C SAE B 2/4 bolt 13T spline

D SAE B 2/4 bolt 15T spline

## **26** Paint

0 No paint

A Blue (standard)

## **27** Customer Identification

0 None

## **28** Design Code

A A (initial release)

# Identification of Parts

Model PVM057

Model PVM063

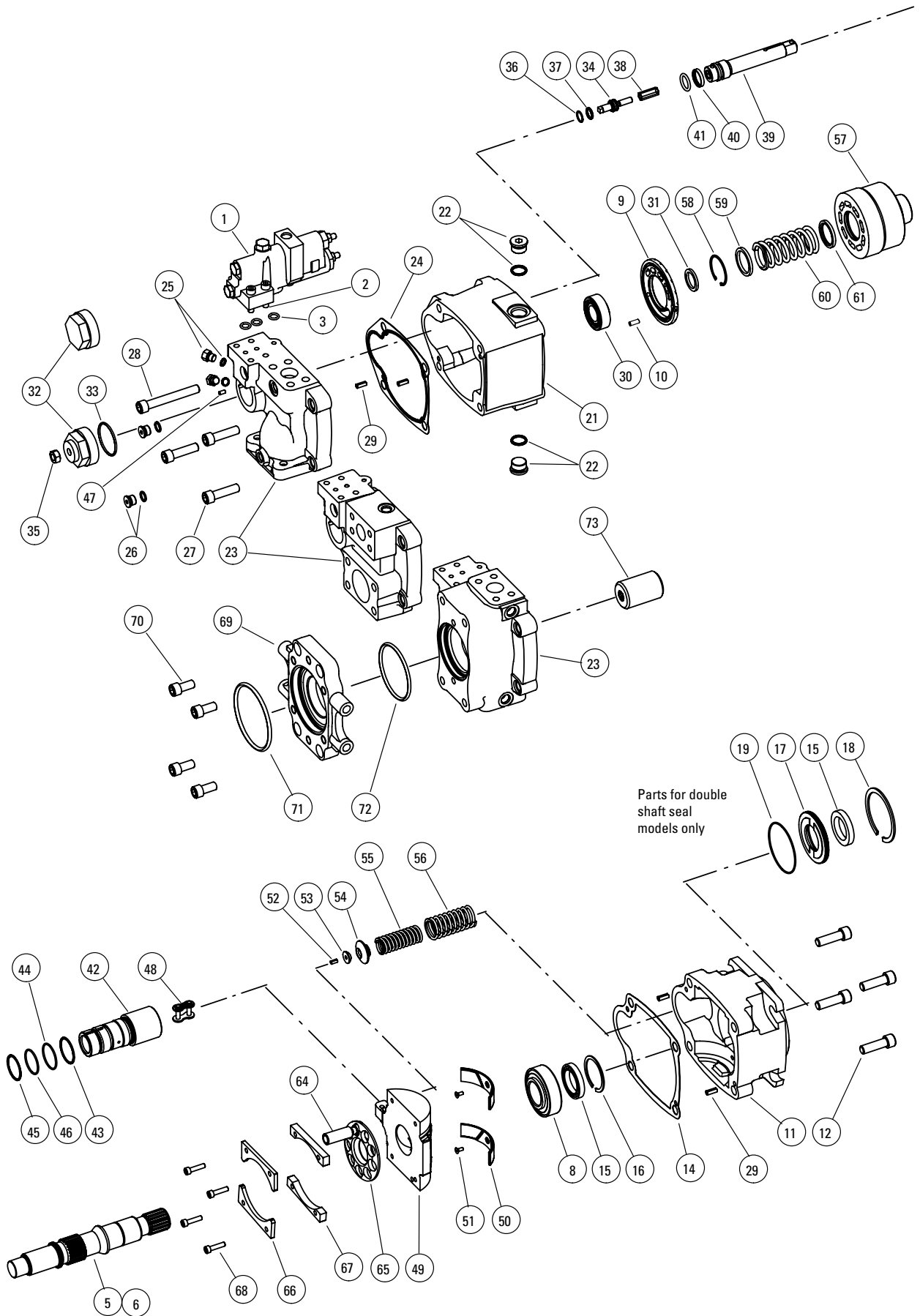

# Parts List

Model PVM057  
Model PVM063

Item	Part No.	Qty.	Note	Description
1	See Table 1	1		Pressure Compensator
2	114975-035	4	A G	Soc HD Cap Screw M5
3	4992737-111	3	A B G	O-Ring
4	Not Used			O-Ring
5	See Table 2	1		Drive Shaft
6	See Table 2	1		Key
7	Not Used			Retaining Ring
8	02-334757	1	E H	Bearing S/A
9	See Table 3	1		Valve Plate
10	95904-068	1		Pin (Valve Plate)
11	See Table 4	1		Mounting Flange
12	114977-040	4		Soc HD Cap Screw M5
13	Not Used			Soc HD Cap Screw M5
14	934445	1	B	Flange Gasket
15	513439	1	B F	Shaft Seal
16	101680-200	1	B F	Retaining Ring
17	934058			Seal Collar
18	101680-300			Retaining Ring
19	104166-040			O-Ring
20	Not Used			Filter
21	See Table 5	1		Housing
22	See Table 5	2		O-Ring Plug S/A
23	See Tables 6&7	1		End Cover
24	934444	1	B	Gasket
25	16103-104	2		O-Ring Plug S/A
26	115046-006	2		O-Ring Plug S/A
27	114977-045	3		Soc HD Cap Screw
28	114977-090	1		Soc HD Cap Screw
29	96201-062	4		Roll Pin
30	02-328741	1	E	Bearing S/A
31	4992188-xxx	A/R	J	Spacer
32	943930	1		Control Cap
33	934580	1	B	O-Ring
34	943985	1		Adjustment Screw
35	4992732-002	1		Jam Nut
36	8770-015	1	B	Back-Up Ring
37	104166-015	1	B	O-Ring
38	937407	1		Hex Stop
39	934052	1		Control Piston
40	934489	1	B	Glide Ring
41	104166-211	1	B	O-Ring
42	934053	1		Sleeve
43	115000-127	1	B	Back-Up Ring
44	104166-127	1	B	O-Ring
45	115000-126	1	B	Back-Up Ring

Item	Part No.	Qty.	Note	Description
46	104166-126	1	B	O-Ring
47	16028-303	1		Pin
48	934493	1	M	Chain Link
49	934086	1		Swashplate
50	943984	2	D	Cradle Bearing
51	114995-010	2	D	Screw Socket Flat Head
52	95749-038	1	D	Pin
53	409998	1	D	Button
54	934429	1	D	Spring Seat
55	937489	1		Inner Bias Spring
56	937488	1		Outer Bias Spring
57	934405	1	C K	Cylinder Barrel (057)
57	934553	1	C L	Cylinder Barrel (063)
58	101680-175	1	C	Retaining Ring
59	584524	1	C	Spring Guide, Outer
60	627524	1	C	Spring
61	680624	1	C	Spring Guide, Inner
62	Not Used			Pin Retainer
63	Not Used			Pin
64	02-306362	9	C K	Piston Shoe S/A (057)
64	02-306363	9	C L	Piston Shoe S/A (063)
65	584512	1	C K	Shoe Retainer (057)
65	860754	1	C L	Shoe Retainer (063)
66	690218	2	C	Hold Down Straps
67	690801	2	C	Spacer
68	114974-025	4	C	Screw
69	See Table 7	1		Adapter
70	114977-025	3		Screw
71	See Table 7	1	B	O-Ring, Adapter
72	See Table 7	1	B	O-Ring, End Cover
73	See Table 8	1		Coupling
74	Not Used			Retaining Ring

A Available in control kit. See Table 1.

B Available in seal kit 02-346217.

C Available in rotating group kit 02-346216 for PVM057 or rotating group kit 02-346224 for PVM063.

D Available in yoke and saddle bearing kit 02-346219.

E Available in shaft bearing kit 02-346220.

F Available in single shaft seal kit 02-346222. Equivalent double shaft seal kit 02-346223.

G Available in control mounting kit 9900105-000.

H Seat bearing cone against shoulder.

J Use spacers to shim as required to obtain 0,01 to 0,10 mm (0.00039 to 0.0039 in.) axial shaft end play.

K For PVM057 only.

L For PVM063 only.

M Warning: Use Vickers authorized chain link only. Cotter pins on industry standard chain link will fail.

# Parts Tables 1 - 8

Model PVM057

Model PVM063

**Table 1 – Pressure Compensator**

Model Code Position			1
13, 14	17, 18, 19	20, 21	
All	A28	00	02-125160
All	A07	00	02-125162
01/02	B28	11	02-346306
01/02	B28	24	02-160591
01/02	C07	24	02-306056
01/02	C28	11	02-346305
01/02	C28	24	02-125161
03/04	B07	11	02-347729
03/04	B08	24	02-347728
03/04	B28	11	02-347730
03/04	B28	24	02-347727
03/04	C28	11	02-346307
03/04	C28	24	02-346308

**Table 2 – Shaft and Key**

Model Code Position			5	6
9, 10	11	25		
06	C	O	937011	4992727-003
07	C	O	934574	–
08	C	O	937009	–
09	E/G	O	937008	114516
11	E/G	O	934338	–
17	E/G	O	937044	4992727-003
18	E/G	O	937050	4992727-001
06	C	A to M	937382	–
07	C	A to M	937383	–
08	C	A to M	937384	–
09	E/G	A to M	937380	–
11	E/G	A to M	937051	–
17	E/H	A to M	939386	–
18	E/H	A to M	937385	–

**Table 3 – Industrial Valve Plate**

Model Code Position		9
4, 5, 6	7, 8	
057	ER	943806
057	MR	943970
057	EL	943971
057	ML	943972
063	ER	943973
063	MR	943974
063	EL	943975
063	ML	943976

**Table 4 – Mounting Flange**

Model Code Position			11
11	13, 14	15, 16	
C	01/02	00/AA/AC	934159
C	01/02	AB/AD	937286
C	03/04	00/AA/AC	937323
C	03/04	AB/AD	937324
D	03/04	00/AA/AC	937287
D	03/04	AB/AD	937288
E	01/02	00/AA/AC	937278
E	01/02	AB/AD	937289
E	03/04	00/AA/AC	937325
E	03/04	AB/AD	937326
F	03/04	00/AA/AC	937290
F	03/04	AB/AD	937291
G	01/02	00/AA/AC	934087
G	01/02	AB/AD	934417
G	03/04	00/AA/AC	937327
G	03/04	AB/AD	937328
H	03/04	00/AA/AC	937001
H	03/04	AB/AD	937002

**Table 5 – Housing**

Model Code Position		21	22
13, 14			
01		934090	115046-010
02		934090	115046-010
03		934599	115050-022
04		934599	115050-022



# Parts Tables 1 - 8

Model PVM057

Model PVM063

**Table 6 – End Cover (Non Thru Drive)**

<b>Model Code Position</b>		<b>23</b>
<b>8</b>	<b>12, 13, 14</b>	
R	S02	934088
R	S04	937208
L	S02	937209
L	S04	937210
R	E01	937375
R	E02	937211
R	E03	937376
R	E04	937248
L	E01	937377
L	E02	934236
L	E03	937144
L	E04	937213

**Table 8 – Coupling**

<b>Model Code Position</b>		<b>73</b>
<b>25</b>	<b>Ref</b>	
A	A9	526682
B	A11	998637
C	B13	526694
D	B15	526695
E	C14	526696
G	MA11	998637
J	MB15	526695
L	MC14	526696

**Table 7 – End Cover (Thru Drive), Adapter and O-Rings**

<b>Model Code Position</b>			<b>23</b>	<b>69</b>	<b>71</b>	<b>72</b>
<b>8</b>	<b>12, 13, 14</b>	<b>25</b>				
R	02	A/B	934251	–	–	576601
R	02	C/D	934251	934296	401525	576601
R	02	E/F	934251	934298	353264	576601
R	04	A/B	937257	–	–	576601
R	04	C/D	937257	934567	401525	576601
R	04	E/F	937257	934569	353264	576601
R	04	G/H	937378	–	–	943809
R	04	J/K	937257	934568	401525	943809
R	04	L/M	937257	934570	353264	943809
L	02	A/B	937258	–	–	576601
L	02	C/D	937258	934296	401525	576601
L	02	E/F	937258	934298	353264	576601
L	04	A/B	937259	–	–	576601
L	04	C/D	937259	934567	401525	576601
L	04	E/F	937259	934569	353264	576601
L	04	G/H	937379	–	–	943809
L	04	J/K	937259	934568	401525	943809
L	04	L/M	937259	934570	353264	943809

## Torque Values

<b>Item</b>	<b>Torque Values</b>
2	31-37 Nm (23-27.4 ft-lb)
12	103-127 Nm (76.2-94 ft-lb)
22	75-83 Nm (55.5-61.4 ft-lb)
25	15-16 Nm (11.1-11.8 ft-lb)
26	29-32 Nm (21.5-23.7 ft-lb)
27	103-127 Nm (76.2-94 ft-lb)
28	103-127 Nm (76.2-94 ft-lb)
32	260-300 Nm (192.4-222 ft-lb)
35	18-24 Nm (13.3-17.8 ft-lb)
51	3,6-4.4 Nm (2.7-3.3 ft-lb)
68	12,9-14,9 Nm (9.6-11 ft-lb)
70	103-127 Nm (76.2-94 ft-lb)

# Identification of Model Code

Model PVM057

Model PVM063

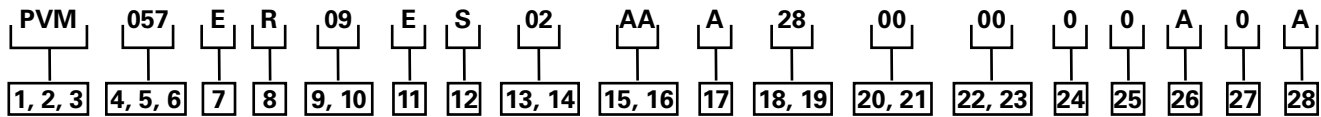

## **[1, 2, 3] Pump Series**

PVM M-Series variable piston pump

## **[4, 5, 6] Displacement**

057 57.4 cm<sup>3</sup>/rev (3.50 in<sup>3</sup>/rev) 280 bar

063 63.1 cm<sup>3</sup>/rev (3.85 in<sup>3</sup>/rev) 230 bar

## **[7] Valve Plate**

E - Industrial (1800 rpm max)

M - Mobile equipment speeds

## **[8] Input Rotation**

R - Clockwise (righthand)

L - Counterclockwise (lefthand)

## **[9, 10] Input Shaft**

05 SAE J744-22-1 B straight key

06 SAE J744-25-1 B-B straight key

07 SAE J744-22-4 B 13T spline

08 SAE J744-25-4 B-B 15T spline

09 SAE J744-32-1 C straight key

10 SAE J744-38-1 C-C straight key

11 SAE J744-32-4 C 14T spline

12 SAE J744-38-4 C-C 17T spline

## **[11] Mounting Flange**

C SAE J744-101-2 (SAE B 2 bolt)

E SAE J744-127-2 (SAE C 2 bolt)

G SAE J744-127-4 (SAE C 4 bolt)

## **[12] Main Port Location**

S Side

E End (na on thru drive)

## **[13, 14] Main Port Type**

01 SAE J514 tube ports

02 SAE J518 flange ports

03 ISO 6149-1 tube ports

04 ISO 6162 flange ports

## **[15, 16] Pump Special Features**

00 None (single shaft seal)

AA Adjustable maximum displacement stop and single shaft seal (standard)

AB Double shaft seal, two way

AD Adjustable maximum displacement stop and double shaft seal

## **[17] Control**

0 None

A Pressure compensator

B Pressure and flow compensator with bleed orifice

C Pressure and flow compensator with plugged orifice

## **[18, 19] Pressure Comp Setting**

00 None

07 66-74 bar (957-1073 psi)

23 227-234 bar (3277-3393 psi) 050 cm<sup>3</sup>/rev

28 276-284 bar (4002-4118 psi) 045 cm<sup>3</sup>/rev

## **[20, 21] Flow Comp Setting**

00 None

11 10-11 bar (145-174 psi)

20 19-21 bar (275.5-304.5 psi)

24 23-25 bar (333.5-362.5 psi)

## **[22, 23] Torque Limiter Setting**

00 None

## **[24] Compensator Special Features**

0 None

## **[25] Auxiliary Mounting Pad**

0 None

A SAE A 2 bolt 9T spline

B SAE A 2 bolt 11T spline

C SAE B 2/4 bolt 13T spline

D SAE B-B 2/4 bolt 15T spline

E SAE C 2/4 bolt 14T spline

## **[26] Paint**

0 No paint

A Blue (standard)

## **[27] Customer Identification**

0 None

## **[28] Design Code**

A A (initial release)

# Identification of Parts

Model PVM074

Model PVM081

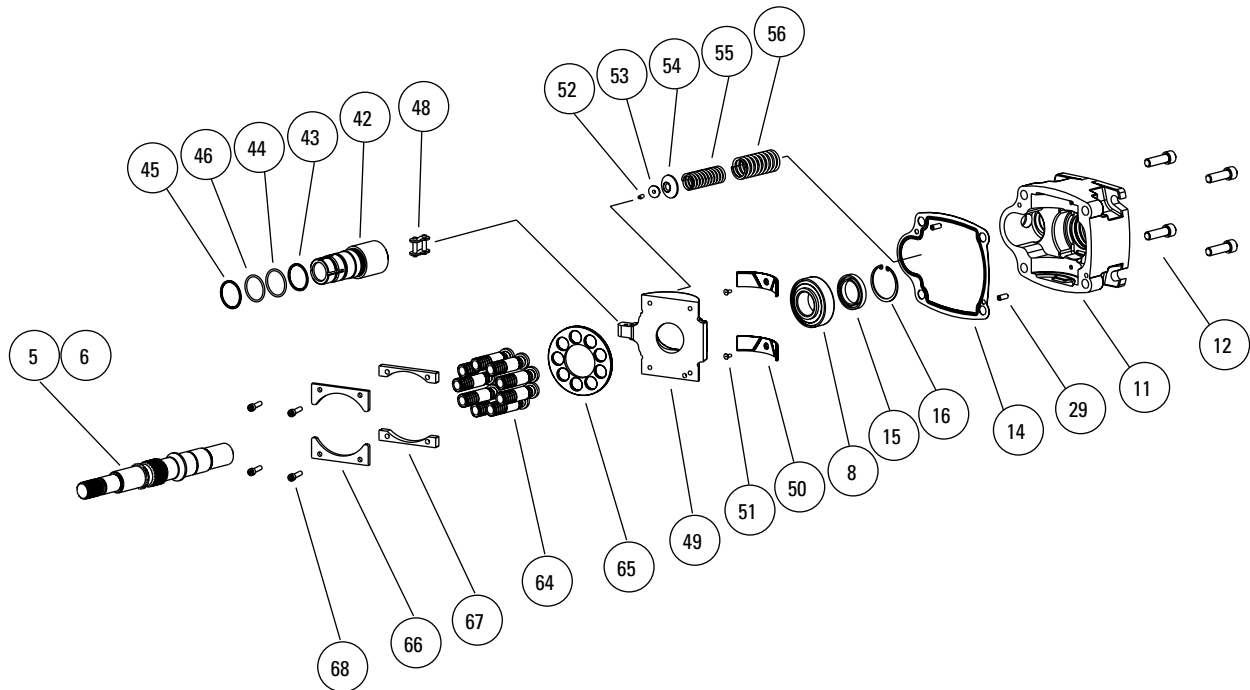
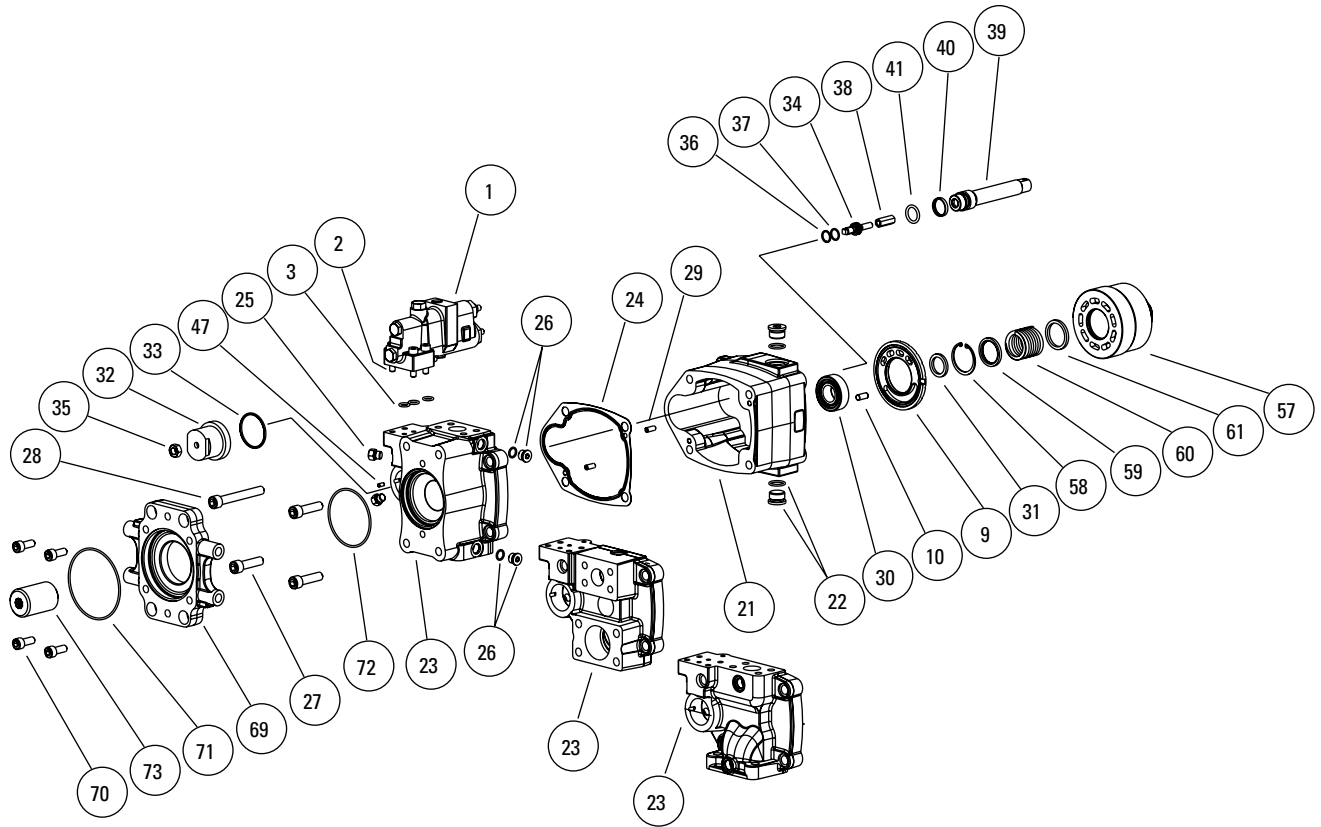

# Parts List

Model PVM074

Model PVM081

Item	Part No.	Qty.	Note	Description
1	See Table 1	1		Pressure Compensator
2	114975-035	4	A G	Soc HD Cap Screw M5
3	4992737-111	3	A B G	O-Ring
4	Not Used	1		O-Ring
5	See Table 2	1		Drive Shaft
6	See Table 2	1		Key
7	Not Used			Retaining Ring
8	02-334431	1	E H	Bearing S/A
9	See Table 3	1		Valve Plate
10	95904-068	1		Pin (Valve Plate)
11	See Table 4	1		Mounting Flange
12	114977-040	6		Soc HD Cap Screw M5
13	Not Used			Soc HD Cap Screw M5
14	943362	1	B	Flange Gasket
15	943427	1	B F	Shaft Seal
16	101680-225	1	B F	Retaining Ring
17	Not Used			Seal Collar
18	Not Used			Retaining Ring
19	Not Used			O-Ring
20	Not Used			Filter
21	See Table 5	1		Housing
22	115046-010	2		O-Ring Plug S/A
23	See Tables 6&7	1		End Cover
24	943361	1	B	Gasket
25	115046-002	8		O-Ring Plug S/A
26	115046-006	3		O-Ring Plug S/A
27	114978-060	4		Soc HD Cap Screw
28	Not Used	1		Soc HD Cap Screw
29	96201-062	4		Roll Pin
30	02-334424	1	E	Bearing S/A
31	4992186-xxx	A/R	J	Spacer
32	943375	1		Control Cap
33	4992737-138	1	B	O-Ring
34	943380	1		Adjustment Screw
35	4992732-002	1		Jam Nut
36	8770-015	1	B	Back-Up Ring
37	104166-015	1	B	O-Ring
38	943381	1		Hex Stop
39	943364	1		Control Piston
40	943367	1	B	Glide Ring
41	104166-118	1	B	O-Ring
42	943363	1		Sleeve
43	115000-131	1	B	Back-Up Ring
44	104166-131	1	B	O-Ring
45	115000-129	1	B	Back-Up Ring

Item	Part No.	Qty.	Note	Description
46	104166-129	1	B	O-Ring
47	95902-050	1		Pin
48	943252	1	M	Chain Link
49	943356	1		Swashplate
50	943378	2	D	Cradle Bearing
51	114995-010	2	D	Screw Socket Flat Head
52	96201-062	1	D	Pin
53	933071	1	D	Button
54	943411	1	D	Spring Seat
55	Not Used			Inner Bias Spring
56	943366	1		Outer Bias Spring
57	943351	1	C K	Cylinder Barrel (074)
57	943376	1	C L	Cylinder Barrel (081)
58	101680-193	1	C	Retaining Ring
59	631568	1	C	Spring Guide, Outer
60	584454	1	C	Spring
61	584483	1	C	Spring Guide, Inner
62	Not Used			Pin Retainer
63	Not Used			Pin
64	02-305857	9	C K	Piston Shoe S/A (074)
64	02-306364	9	C L	Piston Shoe S/A (081)
65	584474	1	C	Shoe Retainer
66	690796	2	C	Hold Down Straps
67	526639	2	C	Spacer
68	114974-025	4	C	Screw
69	See Table 7	1		Adapter
70	473800	3		Screw
71	See Table 7	1	B	O-Ring, Adapter
72	See Table 7	1	B	O-Ring, End Cover
73	See Table 8	1		Coupling
74	Not Used			Retaining Ring

A Available in control kit. See Table 1.

B Available in seal kit 9900107-000.

C Available in rotating group kit 877421 for PVM074 or rotating group kit 314746 for PVM081.

D Available in yoke and saddle bearing kit 9900117-000.

E Available in shaft bearing kit 02-334431.

F Available in single shaft seal kit 02-334433. Equivalent double shaft seal kit 02-340717.

G Available in control mounting kit 9900105-000.

H Seat bearing cone against shoulder.

J Use to to shim as required to obtain 0,01 to 0,10 mm (0.00039 to 0.0039 in.) axial shaft end play.

K For PVM074 only.

L For PVM081 only.

M Warning: Use Vickers authorized chain link only. Cotter pins on industry standard chain link will fail.

# Parts Tables 1 - 8

Model PVM074

Model PVM081

**Table 1 – Pressure Compensator**

<b>Model Code Position</b>			①
<b>13, 14</b>	<b>17, 18, 19</b>	<b>20, 21</b>	
All	A28	00	02-346262
All	A07	00	–
02	B28	11	02-346265
02	B28	24	02-346266
02	C07	24	–
02	C28	11	02-346263
02	C28	24	02-346264
04	B07	11	–
04	B07	24	–
04	B28	11	–
04	B28	24	–
04	C28	11	02-346267
04	C28	24	02-346268

**Table 2 – Shaft and Key**

<b>Model Code Position</b>		⑤	⑥
<b>9, 10</b>	<b>25</b>		
09	O	943428	–
10	O	943429	–
11	O	943368	–
12	O	943430	–
18	O	943431	4992727-001
19	O	943432	–
09	A-M	943433	–
10	A-M	943434	–
11	A-M	943435	–
12	A-M	943436	–
18	A-M	943437	4992727-001
19	A-M	943438	–

**Table 3 – Industrial Valve Plate**

<b>Model Code Position</b>		⑨
<b>4, 5, 6</b>	<b>7, 8</b>	
074	ER	943365
074	MR	943439
074	EL	943440
074	ML	943441
081	ER	943442
081	MR	943443
081	EL	943444
081	ML	943445

**Table 4 – Mounting Flange**

<b>Model Code Position</b>			⑪
<b>11</b>	<b>13, 14</b>	<b>15, 16</b>	
E	02	00/AA/AC	943396
E	02	AB/AD	943998
E	04	00/AA/AC	943400
E	04	AB/AD	943404
F	04	00/AA/AC	943401
F	04	AB/AD	943405
G	02	00/AA/AC	943352
G	02	AB/AD	943373
G	04	00/AA/AC	943402
G	04	AB/AD	943406
H	04	00/AA/AC	943403
H	04	AB/AD	943407

**Table 5 – Housing**

<b>Model Code Position</b>	⑳
<b>13, 14</b>	
02	943354
04	943412

# Parts Tables 1 - 8

Model PVM074

Model PVM081

**Table 6 – End Cover (Non Thru Drive)**

<b>Model Code Position</b>		<b>23</b>
<b>8</b>	<b>12, 13, 14</b>	
R	S02	943358
R	S04	943416
L	S02	943385
L	S04	943423
R	E02	943388
R	E04	943414
L	E02	943383
L	E04	943421

**Table 8 – Coupling**

<b>Model Code Position</b>		<b>73</b>
<b>25</b>	<b>Ref</b>	
A	A9	864460
B	A11	913314
C	B13	864457
D	B15	864459
E	C14	864458
F	C17	864461

**Table 7 – End Cover (Thru Drive), Adapter and O-Rings**

<b>Model Code Position</b>			<b>23</b>	<b>69</b>	<b>71</b>	<b>72</b>
<b>8</b>	<b>12, 13, 14</b>	<b>25</b>				
R	02	A/B	943391	–	–	576601
R	02	C/D	943391	934296	401525	576601
R	02	E/F	943391	934298	353264	576601
R	04	A/B	943418	–	–	943809
R	04	C/D	943418	934567	401525	943809
R	04	E/F	943418	934298	353264	943809
R	04	G/H	943419	–	–	943809
R	04	J/K	943419	934568	943810	943809
R	04	L/M	943419	934570	943811	943809
L	02	A/B	943393	–	–	576601
L	02	C/D	943393	934296	401525	576601
L	02	E/F	943393	934298	353264	576601
L	04	A/B	943425	–	–	576601
L	04	C/D	943425	934296	401525	576601
L	04	E/F	943425	934569	353264	576601
L	04	G/H	943426	–	–	943809
L	04	J/K	943426	934296	943810	943809
L	04	L/M	943426	934570	943811	943809

## Torque Values

<b>Item</b>	<b>Torque Values</b>
2	31-37 Nm (23-27.4 ft-lb)
12	103-127 Nm (76.2-94 ft-lb)
22	75-83 Nm (55.5-61.4 ft-lb)
25	15-16 Nm (11.1-11.8 ft-lb)
26	29-32 Nm (21.5-23.7 ft-lb)
27	103-127 Nm (76.2-94 ft-lb)
32	260-300 Nm (192.4-222 ft-lb)
35	18-24 Nm (13.3-17.8 ft-lb)
51	3,6-4.4 Nm (2.7-3.3 ft-lb)
68	12,9-14,9 Nm (9.6-11 ft-lb)
70	103-127 Nm (76.2-94 ft-lb)

# Identification of Model Code

Model PVM074

Model PVM081

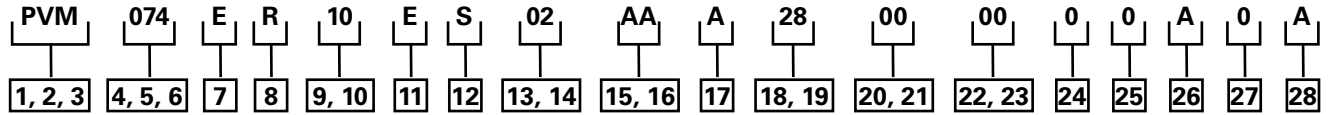

## **1, 2, 3** Pump Series

PVM M-Series variable piston pump

## **4, 5, 6** Displacement

074 73.7 cm<sup>3</sup>/rev (4.50 in<sup>3</sup>/rev) 280 bar  
 081 81.0 cm<sup>3</sup>/rev (4.94 in<sup>3</sup>/rev) 230 bar

## **7** Valve Plate

**E** - Industrial (1800 rpm max)  
**M** - Mobile equipment speeds

## **8** Input Rotation

**R** - Clockwise (righthand)  
**L** - Counterclockwise (lefthand)

## **9, 10** Input Shaft

09 SAE J744-32-1 C straight key  
 10 SAE J744-38-1 C-C straight key  
 11 SAE J744-32-4 C 14T spline  
 12 SAE J744-38-4 C-C 17T spline

## **11** Mounting Flange

**E** SAE J744-127-2 (SAE C 2 bolt)  
**G** SAE J744-127-4 (SAE C 4 bolt)

## **12** Main Port Location

**S** Side  
**E** End (na on thru drive)

## **13, 14** Main Port Type

02 SAE J518 flange ports  
 04 ISO 6162 flange ports

## **15, 16** Pump Special Features

00 None (single shaft seal)  
 AA Adjustable maximum displacement stop and single shaft seal (standard)  
 AB Double shaft seal, two way  
 AD Adjustable maximum displacement stop and double shaft seal

## **17** Control

0 None  
 A Pressure compensator  
 B Pressure and flow compensator with bleed orifice  
 C Pressure and flow compensator with plugged orifice

## **18, 19** Pressure Comp Setting

00 None  
 07 66-74 bar (957-1073 psi)  
 23 227-234 bar (3277-3393 psi) 050 cm<sup>3</sup>/rev  
 28 276-284 bar (4002-4118 psi) 045 cm<sup>3</sup>/rev

## **20, 21** Flow Comp Setting

00 None  
 11 10-11 bar (145-174 psi)  
 20 19-21 bar (275.5-304.5 psi)  
 24 23-25 bar (333.5-362.5 psi)

## **22, 23** Torque Limiter Setting

00 None

## **24** Compensator Special Features

0 None

## **25** Auxiliary Mounting Pad

0 None  
 A SAE A 2 bolt 9T spline  
 B SAE A 2 bolt 11T spline  
 C SAE B 2/4 bolt 13T spline  
 D SAE B-B 2/4 bolt 15T spline  
 E SAE C 2/4 bolt 14T spline  
 F SAE C-C 2/4 bolt 17T spline

## **26** Paint

0 No paint  
 A Blue (standard)

## **27** Customer Identification

0 None

## **28** Design Code

A A (initial release)

# Identification of Parts

Model PVM098

Model PVM106

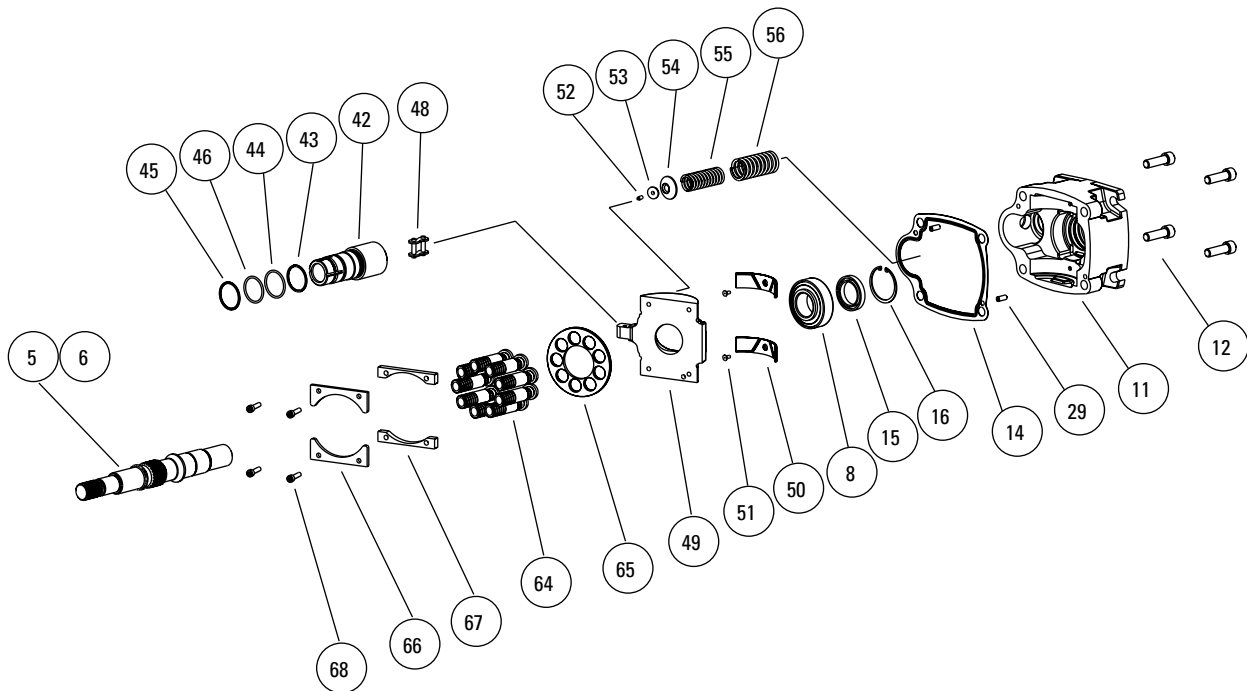
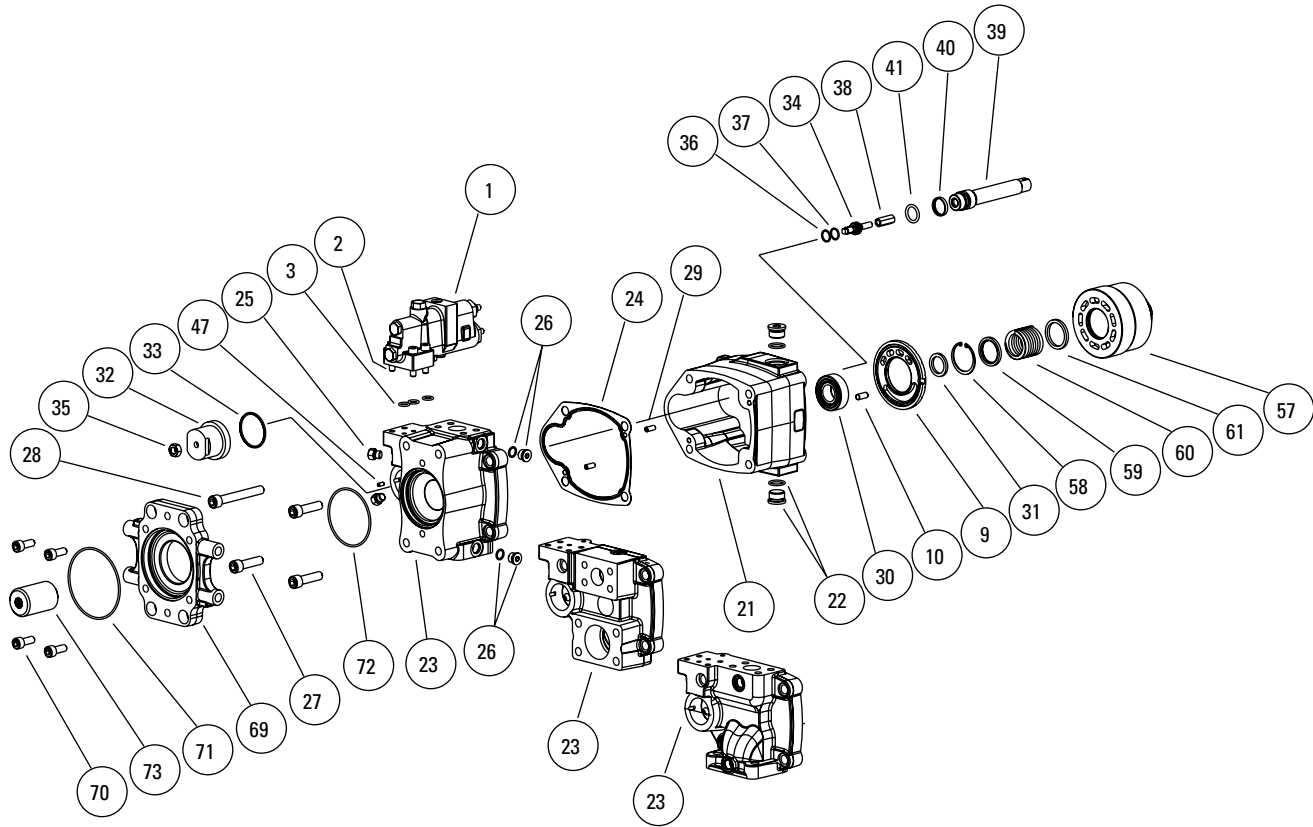



# Parts List

Model PVM098  
Model PVM106

Item	Part No.	Qty.	Note	Description
1	See Table 1	1		Pressure Compensator
2	114975-035	4	A G	Soc HD Cap Screw M5
3	4992737-111	3	A B G	O-Ring
4	Not Used			O-Ring
5	See Table 2	1		Drive Shaft
6	See Table 2	1		Key
7	Not Used			Retaining Ring
8	02-334431	1	E H	Bearing S/A
9	See Table 3	1		Valve Plate
10	95904-068	1		Pin (Valve Plate)
11	See Table 4	1		Mounting Flange
12	114977-040	6		Soc HD Cap Screw M5
13	Not Used	1		Soc HD Cap Screw M5
14	943212	1	B	Flange Gasket
15	943427	1	B F	Shaft Seal
16	101680-225	1	B F	Retaining Ring
17	Not Used			Seal Collar
18	Not Used			Retaining Ring
19	Not Used			O-Ring
20	Not Used			Filter
21	See Table 5	1		Housing
22	115046-010	2		O-Ring Plug S/A
23	See Tables 6&7	1		End Cover
24	943211	1	B	Gasket
25	115046-002	7		O-Ring Plug S/A
26	115046-006	3		O-Ring Plug S/A
27	114978-060	3		Soc HD Cap Screw
28	114978-090	1		Soc HD Cap Screw
29	96201-062	4		Roll Pin
30	02-334432	1	E	Bearing S/A
31	4992185-xxx	A/R	J	Spacer
32	943222	1		Control Cap
33	4992737-138	1	B	O-Ring
34	943227	1		Adjustment Screw
35	4992732-002	1		Jam Nut
36	8770-015	1	B	Back-Up Ring
37	104166-015	1	B	O-Ring
38	943228	1		Hex Stop
39	943214	1		Control Piston
40	943367	1	B	Glide Ring
41	104166-118	1	B	O-Ring
42	943213	1		Sleeve
43	115000-131	1		B Back-Up Ring
44	104166-131	1	B	O-Ring
45	115000-129	1	B	Back-Up Ring

Item	Part No.	Qty.	Note	Description
46	104166-129	1	B	O-Ring
47	95902-050	1		Pin
48	943252	1	M	Chain Link
49	943206	1		Swashplate
50	943226	2	D	Cradle Bearing
51	114995-010	2	D	Screw Socket Flat Head
52	96201-062	1	D	Pin
53	933071	1	D	Button
54	943219	1	D	Spring Seat
55	Not Used			Inner Bias Spring
56	943216	1		Outer Bias Spring
57	943201	1	C K	Cylinder Barrel (098)
57	943223	1	C L	Cylinder Barrel (106)
58	101680-212	1	C	Retaining Ring
59	584547	1	C	Spring Guide, Outer
60	627192	1	C	Spring
61	584546	1	C	Spring Guide, Inner
62	Not Used			Pin Retainer
63	Not Used			Pin
64	02-152400	9	C K	Piston Shoe S/A (098)
64	02-306365	9	C L	Piston Shoe S/A (106)
65	584539	1	C	Shoe Retainer
66	513626	2	C	Hold Down Straps
67	513625	2	C	Spacer
68	114975-030	4	C	Screw
69	See Table 7	1		Adapter
70	473800	3		Screw
71	See Table 7	1	B	O-Ring, Adapter
72	See Table 7	1	B	O-Ring, End Cover
73	See Table 8	1		Coupling
74	Not Used	1		Retaining Ring

- A Available in control kit. See Table 1.
- B Available in seal kit 9900109-000.
- C Available in rotating group kit 877422 for PVM098 or rotating group kit 159812 for PVM106.
- D Available in yoke and saddle bearing kit 9900106-000.
- E Available in shaft bearing kit 9900110-000.
- F Available in single shaft seal kit 02-334433. Equivalent double shaft seal kit 02-340717.
- G Available in control mounting kit 9900105-000.
- H Seat bearing cone against shoulder.
- J Use to shim as required to obtain 0,01 to 0,10 mm (0.00039 to 0.0039 in.) axial shaft end play.
- K For PVM098 only.
- L For PVM106 only.
- M Warning: Use Vickers authorized chain link only. Cotter pins on industry standard chain link will fail.

# Parts Tables 1 - 8

Model PVM098

Model PVM106

**Table 1 – Pressure Compensator**

<b>Model Code Position</b>			①
<b>13, 14</b>	<b>17, 18, 19</b>	<b>20, 21</b>	
All	A28	00	02-346262
All	A07	00	–
02	B28	11	02-346265
02	B28	24	02-346266
02	C07	24	–
02	C28	11	02-346263
02	C28	24	02-346264
04	B07	11	–
04	B07	24	–
04	B28	11	–
04	B28	24	–
04	C28	11	02-346267
04	C28	24	02-346268

**Table 2 – Shaft and Key**

<b>Model Code Position</b>		⑤	⑥
<b>9, 10</b>	<b>25</b>		
09	O	943305	–
10	O	943306	–
11	O	943218	–
12	O	943307	–
18	O	943308	4992727-001
19	O	943309	–
09	A-M	943310	–
10	A-M	943311	–
11	A-M	943312	–
12	A-M	943313	–
18	A-M	943314	4992727-001
19	A-M	943315	–

**Table 3 – Valve Plate**

<b>Model Code Position</b>		⑨
<b>4, 5, 6</b>	<b>7, 8</b>	
098	ER	943316
098	MR	943219
098	EL	943317
098	ML	943318
106	ER	943342
106	MR	943343
106	EL	943344
106	ML	943345

**Table 4 – Mounting Flange**

<b>Model Code Position</b>			⑪
<b>11</b>	<b>13, 14</b>	<b>15, 16</b>	
E	02	00/AA/AC	943275
E	02	AB/AD	943341
E	04	00/AA/AC	943277
E	04	AB/AD	943281
F	04	00/AA/AC	943278
F	04	AB/AD	943282
G	02	00/AA/AC	943202
G	02	AB/AD	943220
G	04	00/AA/AC	943279
G	04	AB/AD	943283
H	04	00/AA/AC	943280
H	04	AB/AD	943284

**Table 5 – Housing**

<b>Model Code Position</b>	⑰
<b>13, 14</b>	
02	943204
04	943289

# Parts Tables 1 - 8

Model PVM098

Model PVM106

**Table 6 – End Cover (Non Thru Drive)**

<b>Model Code Position</b>		<b>23</b>
<b>8</b>	<b>12, 13, 14</b>	
R	S02	943208
R	S04	943293
L	S02	943235
L	S04	943300
R	E02	943238
R	E04	943291
L	E02	943241
L	E04	943298

**Table 8 – Coupling**

<b>Model Code Position</b>		<b>73</b>
<b>25</b>	<b>Ref</b>	
A	A9	864460
B	A11	913314
C	B13	864457
D	B15	864459
E	C14	864458
F	C17	864461

**Table 7 – End Cover (Thru Drive), Adapter and O-Rings**

<b>Model Code Position</b>			<b>23</b>	<b>69</b>	<b>71</b>	<b>72</b>
<b>8</b>	<b>12, 13, 14</b>	<b>25</b>				
R	02	A/B	943246	–	–	576601
R	02	C/D	943246	934296	401525	576601
R	02	E/F	943246	934298	353264	576601
R	04	A/B	943295	–	–	943809
R	04	C/D	943295	934567	401525	943809
R	04	E/F	943295	934569	353264	943809
R	04	G/H	943296	–	–	943809
R	04	J/K	943296	934568	943810	943809
R	04	L/M	943296	934570	943811	943809
L	02	A/B	943246	–	–	576601
L	02	C/D	943246	934296	401525	576601
L	02	E/F	943246	934298	353264	576601
L	04	A/B	943302	–	–	576601
L	04	C/D	943302	934567	401525	576601
L	04	E/F	943302	934569	353264	576601
L	04	G/H	943303	–	–	943809
L	04	J/K	943303	934568	943810	943809
L	04	L/M	943303	934570	943811	943809

## Torque Values

<b>Item</b>	<b>Torque Values</b>
2	31-37 Nm (23-27.4 ft-lb)
12	103-127 Nm (76.2-94 ft-lb)
22	75-83 Nm (55.5-61.4 ft-lb)
25	15-16 Nm (11.1-11.8 ft-lb)
26	29-32 Nm (21.5-23.7 ft-lb)
27	103-127 Nm (76.2-94 ft-lb)
28	103-127 Nm (76.2-94 ft-lb)
32	260-300 Nm (192.4-222 ft-lb)
35	18-24 Nm (13.3-17.8 ft-lb)
51	3,6-4.4 Nm (2.7-3.3 ft-lb)
68	12,9-14,9 Nm (9.6-11 ft-lb)
70	103-127 Nm (76.2-94 ft-lb)

# Identification of Model Code

Model PVM098

Model PVM106

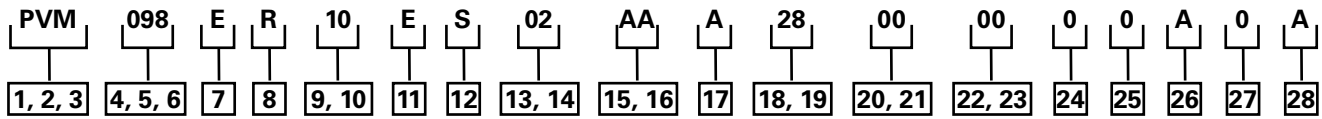

## 1, 2, 3 Pump Series

PVM M-Series variable piston pump

## 4, 5, 6 Displacement

098 98.3 cm<sup>3</sup>/rev (6.0 in<sup>3</sup>/rev)  
280 bar  
106 106.5 cm<sup>3</sup>/rev (6.5 in<sup>3</sup>/rev)  
230 bar

## 7 Valve Plate

E - Industrial (1800 rpm max)  
M - Mobile equipment speeds

## 8 Input Rotation

R - Clockwise (righthand)  
L - Counterclockwise (lefthand)

## 9, 10 Input Shaft

09 SAE J744-32-1 C straight key  
10 SAE J744-38-1 C-C straight key  
11 SAE J744-32-4 C 14T spline  
12 SAE J744-38-4 C-C 17T spline

## 11 Mounting Flange

E SAE J744-127-2 (SAE C 2 bolt)  
G SAE J744-127-4 (SAE C 4 bolt)

## 12 Main Port Location

S Side  
E End (na on thru drive)

## 13, 14 Main Port Type

02 SAE J518 flange ports  
04 ISO 6162 flange ports

## 15, 16 Pump Special Features

00 None (single shaft seal)  
AA Adjustable maximum displacement stop and single shaft seal (standard)  
AB Double shaft seal, two way  
AD Adjustable maximum displacement stop and double shaft seal

## 17 Control

0 None  
A Pressure compensator  
B Pressure and flow compensator with bleed orifice  
C Pressure and flow compensator with plugged orifice

## 18, 19 Pressure Comp Setting

00 None  
07 66-74 bar (957-1073 psi)  
23 227-234 bar (3277-3393 psi) 050 cm<sup>3</sup>/rev  
28 276-284 bar (4002-4118 psi) 045 cm<sup>3</sup>/rev

## 20, 21 Flow Comp Setting

00 None  
11 10-11 bar (145-174 psi)  
20 19-21 bar (275.5-304.5 psi)  
24 23-25 bar (333.5-362.5 psi)

## 22, 23 Torque Limiter Setting

00 None

## 24 Compensator Special Features

0 None

## 25 Auxiliary Mounting Pad

0 None  
A SAE A 2 bolt 9T spline  
B SAE A 2 bolt 11T spline  
C SAE B 2/4 bolt 13T spline  
D SAE B-B 2/4 bolt 15T spline  
E SAE C 2/4 bolt 14T spline  
F SAE C-C 2/4 bolt 17T spline

## 26 Paint

0 No paint  
A Blue (standard)

## 27 Customer Identification

0 None

## 28 Design Code

A A (initial release)

# Identification of Parts

Model PVM131

Model PVM141

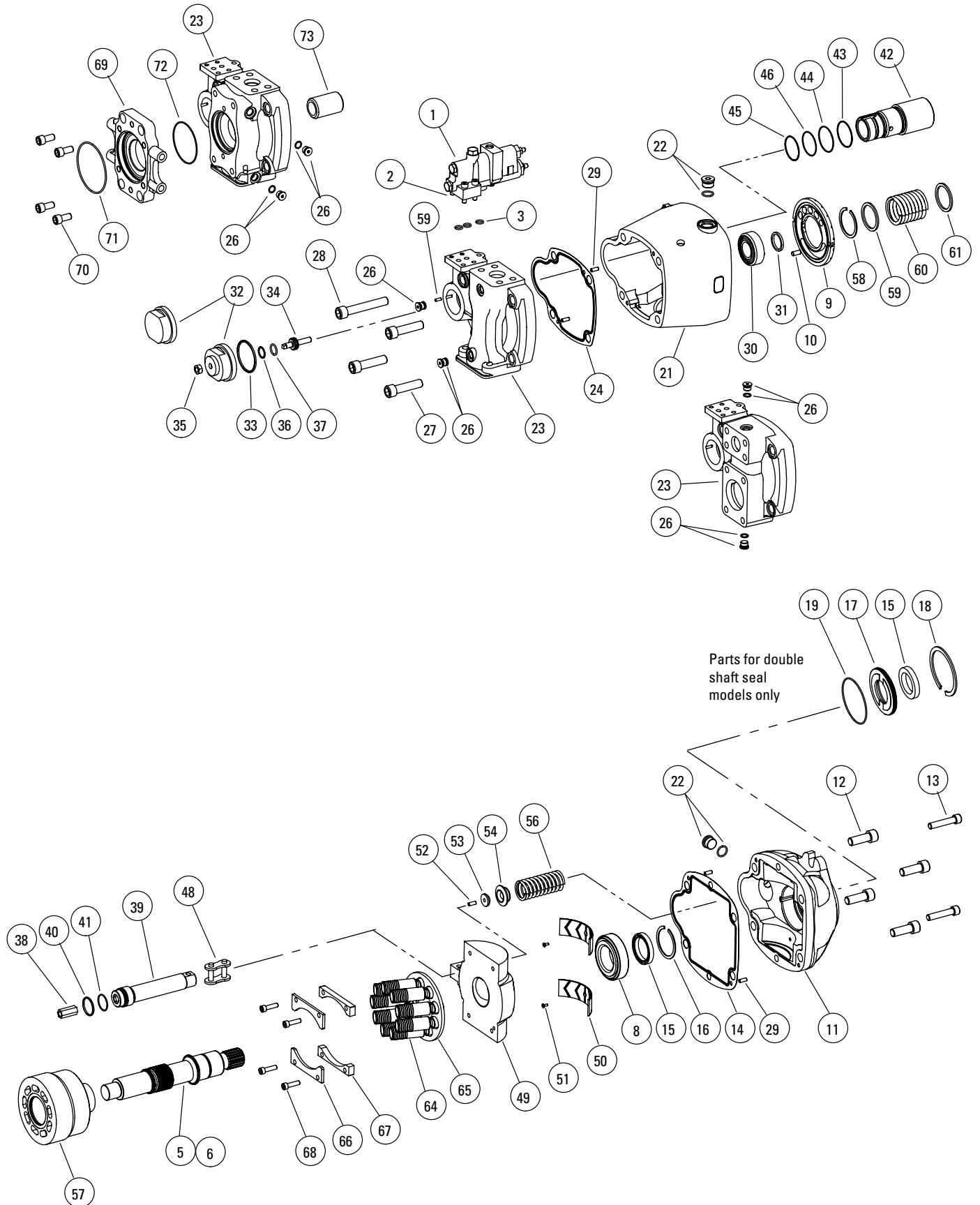

# Parts List

Model PVM131

Model PVM141

Item	Part No.	Qty.	Note	Description
1	See Table 1	1		Pressure Compensator
2	114975-035	4	A G	Soc HD Cap Screw M5
3	4992737-111	3	A B G	O-Ring
4	Not Used			O-Ring
5	See Table 2	1		Drive Shaft
6	See Table 2	1		Key
7	Not Used			Retaining Ring
8	388206	1	E H	Bearing S/A
9	See Table 3	1		Valve Plate
10	95904-068	1		Pin (Valve Plate)
11	See Table 4	1		Mounting Flange
12	114978-045	4		Soc HD Cap Screw M5
13	114977-060	2		Soc HD Cap Screw M5
14	933088	1	B	Flange Gasket
15	864200	1	B F	Shaft Seal
16	115019-250	1	B F	Retaining Ring
17	934403	1		Seal Collar
18	115018-350	1	B F	Retaining Ring
19	104166-152	1		O-Ring
20	882993			Filter
21	See Table 5	1		Housing
22	115046-010	2		O-Ring Plug S/A
23	See Tables 6&7	1		End Cover
24	933087	1	B	Gasket
25	Not Used			O-Ring Plug S/A
26	115046-006	2		O-Ring Plug S/A
27	114978-065	3		Soc HD Cap Screw
28	114978-100	1		Soc HD Cap Screw
29	96201-062	4		Roll Pin
30	02-328957	1	E	Bearing S/A
31	4992187-xxx	A/R	J	Spacer
32	934488	1		Control Cap
33	933080	1	B	O-Ring
34	934474	1		Adjustment Screw
35	4992732-002	1		Jam Nut
36	8770-116	1	B	Back-Up Ring
37	104166-116	1	B	O-Ring
38	934466	1		Hex Stop
39	933049	1		Control Piston
40	933078	1	B	Glide Ring
41	104166-123	1	B	O-Ring
42	933076	1		Sleeve
43	114998-033	1	B	Back-Up Ring
44	104166-033	1	B	O-Ring
45	114998-032	1	B	Back-Up Ring

Item	Part No.	Qty.	Note	Description
46	104166-032	1	B	O-Ring
47	95902-050	1		Pin
48	934026	1	M	Chain Link
49	933089	1		Swashplate
50	933095	2	D	Cradle Bearing
51	114995-010	2	D	Screw Socket Flat Head
52	96201-062	1	D	Pin
53	933071	1	D	Button
54	933081	1	D	Spring Seat
55	Not Used			Inner Bias Spring
56	933079	1	C	Outer Bias Spring
57	933082	1	C K	Cylinder Barrel (131)
57	937030	1	C L	Cylinder Barrel (141)
58	101680-231	1	C	Retaining Ring
59	581104	1	C	Spring Guide, Outer
60	626111	1	C	Spring
61	417667	1	C	Spring Guide, Inner
62	Not Used			Pin Retainer
63	Not Used			Pin
64	02-159749	9	C K	Piston Shoe S/A (131)
64	02-306332	9	C L	Piston Shoe S/A (141)
65	683791	1	C K	Shoe Retainer (131)
65	928776	1	C L	Shoe Retainer (141)
66	526758	2	C	Hold Down Straps
67	526757	2	C	Spacer
68	114975-030	4	C	Screw
69	See Table 7	1		Adapter
70	473800	3		Screw
71	See Table 7	1	B	O-Ring, Adapter
72	See Table 7	1	B	O-Ring, End Cover
73	See Table 8	1		Coupling
74	Not Used			Retaining Ring

A Available in control kit, Table 1.

B Available in seal kit 02-346168.

C Available in rotating group kit 02-346169 for PVM131 or rotating group kit 02-322898 for PVM141.

D Available in yoke and saddle bearing kit 02-346170.

E Available in shaft bearing kit 02-346171.

F Available in single shaft seal kit 02-346173. Equivalent double shaft seal kit 02-346174.

G Available in control mounting kit 9900105-000.

H Seat bearing cone against shoulder.

J Use to to shim as required to obtain 0,01 to 0,10 mm (0.00039 to 0.0039 in.) axial shaft end play.

K For PVM131 only.

L For PVM141 only.

M Warning: Use Vickers authorized chain link only. Cotter pins on industry standard chain link will fail.

# Parts Tables 1 - 8

Model PVM131

Model PVM141

**Table 1 – Pressure Compensator**

Model Code Position			①
13, 14	17, 18, 19	20, 21	
All	A28	00	02-346262
All	A07	00	–
02	B28	11	02-346265
02	B28	24	02-346266
02	C07	24	–
02	C28	11	02-346263
02	C28	24	02-346264
04	B07	11	–
04	B07	24	–
04	B28	11	–
04	B28	24	–
04	C28	11	02-346267
04	C28	24	02-346268

**Table 2 – Shaft and Key**

Model Code Position			⑤	⑥
9, 10	11	25		
09	E/G	O	934463	114516
10	E/G	O	934420	140282
11	E/G	O	934464	–
12	E/G	O	933098	–
13	J	O	934462	633260
14	J	O	934285	–
18	F/H	O	934465	928546
19	F/H	O	934467	928547
09	E/G	A-F	934469	114516
10	E/G	A-F	934471	140282
11	E/G	A-F	934470	–
12	E/G	A-F	934295	–
13	J	A-F	934472	633260
14	J	A-F	934321	–
18	F/H	A-F	934473	928546
19	F/H	A-F	934475	928547

**Table 3 – Industrial Valve Plate**

Model Code Position		⑨
4, 5, 6	7, 8	
057	ER	937017
057	MR	933083
057	EL	937167
057	ML	937168
063	ER	937169
063	MR	934292
063	EL	937170
063	ML	937171

**Table 4 – Mounting Flange**

Model Code Position			⑪
11	13, 14	15, 16	
E	02	00/AA/AC	934520
E	02	AB/AD	934522
F	04	00/AA/AC	934525
F	04	AB/AD	934527
G	02	00/AA/AC	933091
G	02	AB/AD	934404
G	04	00/AA/AC	934558
G	04	AB/AD	934562
H	04	00/AA/AC	934554
H	04	AB/AD	934556
J	02	00/AA/AC	934282
J	02	AB/AD	934571
J	04	00/AA/AC	934560
J	04	AB/AD	934564
K	04	00/AA/AC	934555
K	04	AB/AD	934565

**Table 5 – Housing**

Model Code Position		⑫
13, 14		
02		933093
04		934566

# Parts Tables 1 - 8

Model PVM131

Model PVM141

**Table 6 – End Cover (Non Thru Drive)**

Model Code Position		23
8	12, 13, 14	
R	S02	933096
R	S04	934499
L	S02	934289
L	S04	934504
R	E02	934413
R	E04	934498
L	E02	934502
L	E04	934503

**Table 8 – Coupling**

Model Code Position		73
25	Ref	
A	A9	877039
B	A11	913411
C	B13	877040
D	B15	877044
E	C14	877045
F	C17	877046

**Table 7 – End Cover (Thru Drive), Adapter and O-Rings**

Model Code Position			23	69	71	72
8	12, 13, 14	25				
R	02	A/B	934284	–	–	576601
R	02	C/D	934284	934296	401525	576601
R	02	E/F	934284	934298	353264	576601
R	04	A/B	934500	–	–	943809
R	04	C/D	934500	934567	401525	943809
R	04	E/F	934500	934569	353264	943809
R	04	G/H	934501	–	–	943809
R	04	J/K	934501	934568	943810	943809
R	04	L/M	934501	934570	943811	943809
L	02	A/B	934505	–	–	576601
L	02	C/D	934505	934296	401525	576601
L	02	E/F	934505	934298	353264	576601
L	04	A/B	934506	–	–	576601
L	04	C/D	934506	934567	401525	576601
L	04	E/F	934506	934569	353264	576601
L	04	G/H	934507	–	–	943809
L	04	J/K	934507	934568	943810	943809
L	04	L/M	934507	934570	943811	943809

## Torque Values

Item	Torque Values
2	31-37 Nm (23-27.4 ft-lb)
12	257-315 Nm (190-232 ft-lb)
13	103-127 Nm (76-94 ft-lb)
22	75-83 Nm (55-61 ft-lb)
26	29-32 Nm (21-23 ft-lb)
27	57-315 Nm (190-232 ft-lb)
28	257-315 Nm (190-232 ft-lb)
32	236-265 Nm (174-195 ft-lb)
35	24-30 Nm (17-22 ft-lb)
51	3,6-4,4 Nm (2.6-3.2 ft-lb)
68	31-37 Nm (23-27 ft-lb)
70	103-127 Nm (76-94 ft-lb)



# Identification of Model Code

Model PVM131

Model PVM141

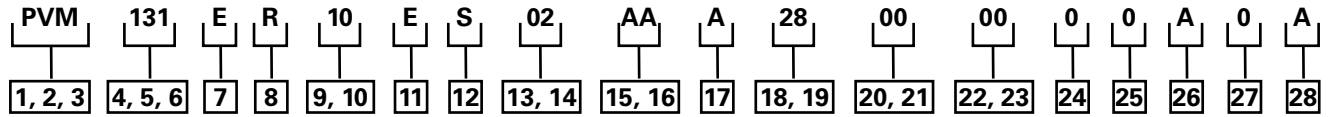

## **1, 2, 3** Pump Series

PVM M-Series variable piston pump

## **4, 5, 6** Displacement

131 131.1 cm<sup>3</sup>/rev (8.0 in<sup>3</sup>/rev) 280 bar

141 141.0 cm<sup>3</sup>/rev (8.6 in<sup>3</sup>/rev) 230 bar

## **7** Valve Plate

**E** - Industrial (1800 rpm max)

**M** - Mobile equipment speeds

## **8** Input Rotation

**R** - Clockwise (righthand)

**L** - Counterclockwise (lefthand)

## **9, 10** Input Shaft

09 SAE J744-32-1 C straight key

10 SAE J744-38-1 C-C straight key

11 SAE J744-32-4 C 14T spline

12 SAE J744-38-1 C-C 17T spline

13 SAE J744-44-1 D straight key

14 SAE J744-44-2 D 13T spline

## **11** Mounting Flange

**E** SAE J744-127-2 (SAE C 2 bolt)

**G** SAE J744-127-4 (SAE C 4 bolt)

**J** SAE J744-152-4 (SAE D 4 bolt)

## **12** Main Port Location

**S** Side

**E** End (na on thru drive)

## **13, 14** Main Port Type

02 SAE J518 flange ports

04 ISO 6162 flange ports

## **15, 16** Pump Special Features

00 None (single shaft seal)

AA Adjustable maximum displacement stop and single shaft seal (standard)

AB Double shaft seal, two way

AD Adjustable maximum displacement stop and double shaft seal

## **17** Control

0 None

**A** Pressure compensator

**B** Pressure and flow compensator with bleed orifice

**C** Pressure and flow compensator with plugged orifice

## **18, 19** Pressure Comp Setting

00 None

07 66-74 bar (957-1073 psi)

23 227-234 bar (3277-3393 psi) 050 cm<sup>3</sup>/rev

28 276-284 bar (4002-4118 psi) 045 cm<sup>3</sup>/rev

## **20, 21** Flow Comp Setting

00 None

11 10-11 bar (145-174 psi)

20 19-21 bar (275.5-304.5 psi)

24 23-25 bar (333.5-362.5 psi)

## **22, 23** Torque Limiter Setting

00 None

## **24** Compensator Special Features

0 None

## **25** Auxiliary Mounting Pad

0 None

**A** SAE A 2 bolt 9T spline

**B** SAE A 2 bolt 11T spline

**C** SAE B 2/4 bolt 13T spline

**D** SAE B-B 2/4 bolt 15T spline

**E** SAE C 2/4 bolt 14T spline

**F** SAE C-C 2/4 bolt 17T spline

## **26** Paint

0 No paint

**A** Blue (standard)

## **27** Customer Identification

0 None

## **28** Design Code

**A** A (initial release)

# General Information

## Ordering Replacement Parts

### Replacement Parts

When ordering replacement parts, give the product number, date code, part name, part number and quantity of parts required. This product information is found stamped on the tag which is located on the side of the housing.

When the Eaton model PVM pressure, pressure-flow compensated piston pump is repaired, thoroughly clean the pump before any repairs are attempted. The part number and serial number are on the tag.

### Read this assembly manual thoroughly before starting work on the pump

This manual assumes appropriately trained technicians with specialized knowledge of mechanical and hydraulic component assembly and disassembly.

### Serial Number/Date Code Interpretation

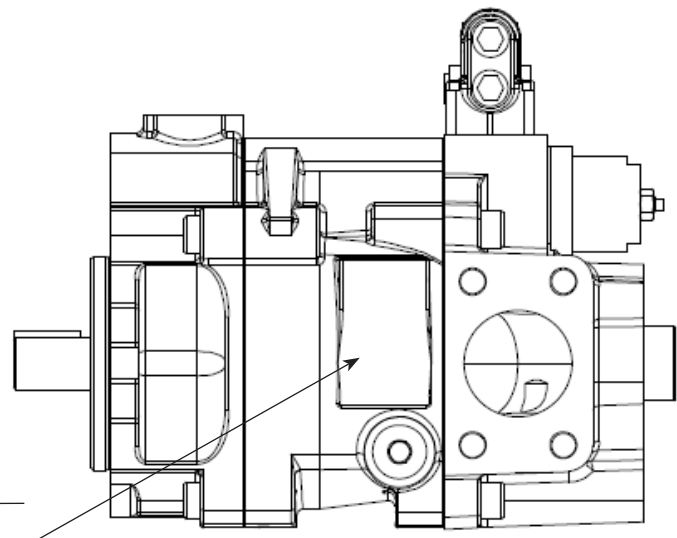
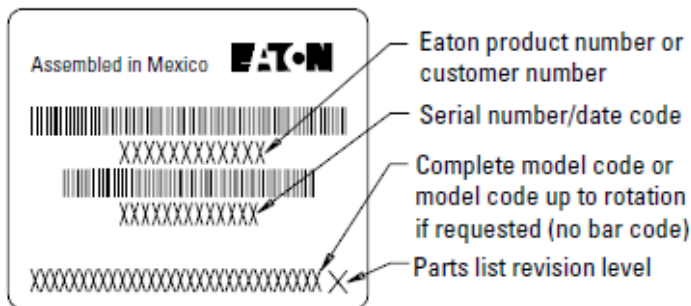
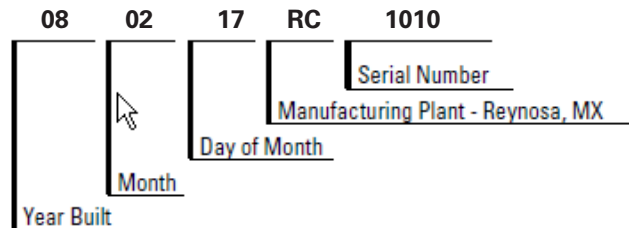

### Required Tools:

- Ball peen hammer
- Plastic tip hammer
- Hex (Allen) wrenches
- Wrenches
- Flat tip screw driver
- Lock ring pliers
- Torque Wrench
- Rubber tip hammer
- Petroleum jelly
- Cleaning solvent

### Special Tools:

- Dial indicator and Accessories
- Bearing race removal tool, shim stock and Cylinder block spring decompression tool
- Shaft seal assembly tool
- Force indicator tool
- Bearing race installation tool
- Shim stock or Teflon material 8" x 3" x .003"
- 2 Studs (8" long x 0.437 – 14 dia./C1 – 2A thd. Class

# Disassembly, Inspection and Reassembly

## A. General

In most cases, the pump will not require a complete overhaul as described within this section. If the pump needs a complete overhaul, use the service tools listed below. Repair of this unit is intricate and should not be attempted without proper tools.

## B. Required Tools Standard Tools for Disassembly:

- Ball peen hammer
- Plastic tip hammer
- Hex (Allen) wrenches
- Wrenches
- Flat tip screw driver
- Lock ring pliers
- Torque Wrench
- Rubber tip hammer
- Petroleum jelly
- Cleaning solvent

## Special Tools:

- Dial indicator and Accessories
- Bearing race removal tool, shim stock and Cylinder block spring decompression tool
- Shaft seal assembly tool
- Force indicator tool
- Bearing race installation tool
- Shim stock or Teflon material 8" x 3" x .003"
- 2 Studs (8" long x 0.437 – 14 dia./C1 – 2A thd. class)

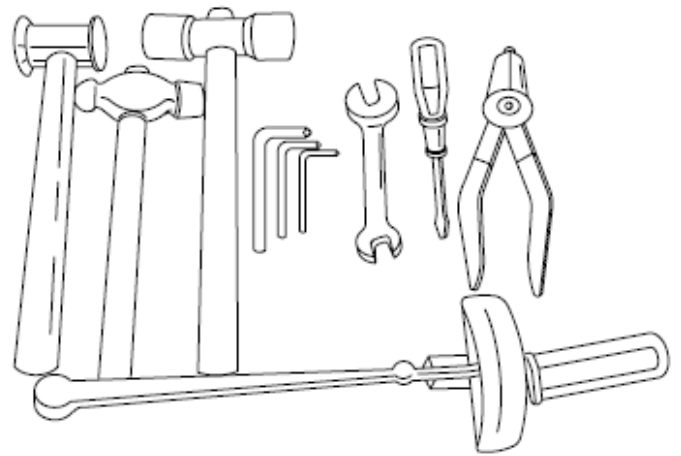

Standard Tools

# Disassembly

Before attempting to disassemble, clean the pump exterior. Dispose of leakage oil and oily cloths in an environmentally responsible manner. All parts within the unit must be kept clean during the overhaul process. Handle each part with great care, marking as necessary to ensure proper reassembly. The close tolerance of the parts makes this requirement very important. Clean all parts that are removed from the unit with a commercial solvent that is compatible with the system fluid. Compressed air may be used in the cleaning process. However, it must be filtered to remove water and other contamination.

## 1. Remove Control

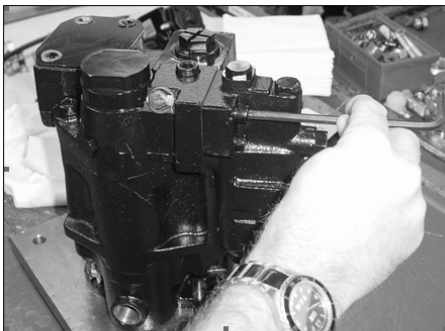

Note: Remove and discard three O-rings.

## 2. Remove Maximum Displacement Stop Screw

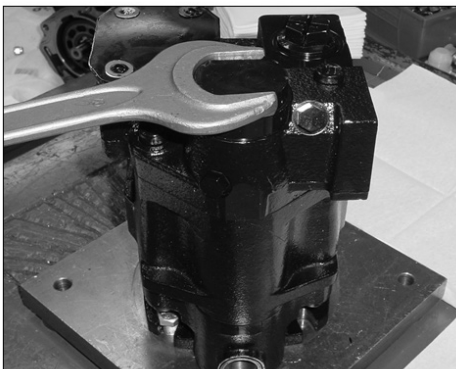

Note: Remove lock nut and turn the adjusting screw so it does not bottom out in either direction. After loosening the control cap, tap on the cap with rubber mallet to loosen the control sleeve in the end cover.

## 3. Loosen End Cover screws

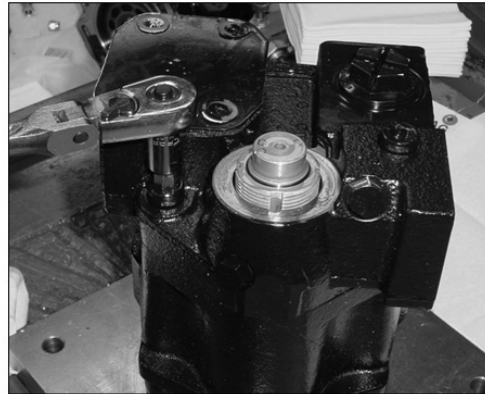

Note: While loosening the end cover socket heat cap screws (SHCS), first remove two end cover SHCS opposite of each other and replace with 8" studs referenced in the special tools section. Then remove remaining four SHCS.

## 4. Remove End Cover



Note: To dislodge end cover from the pump housing, tap on side of end cover with a rubber mallet. Be careful not to damage the valve plate or end cover during this operation.

# Disassembly

## 5. Remove Valve Plate

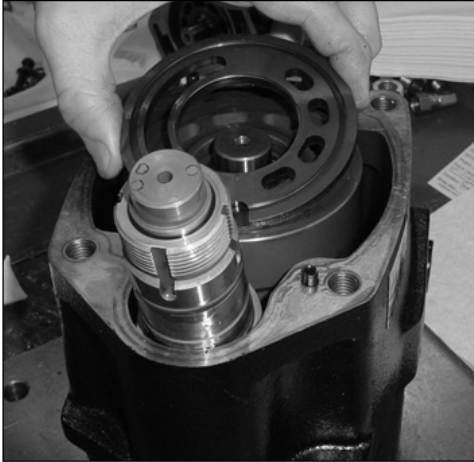

## 6. Remove and Discard End Cover Gasket



## 7. Remove Tail Roller Bearing and Shims



## 8. Remove Housing and Flange Gasket

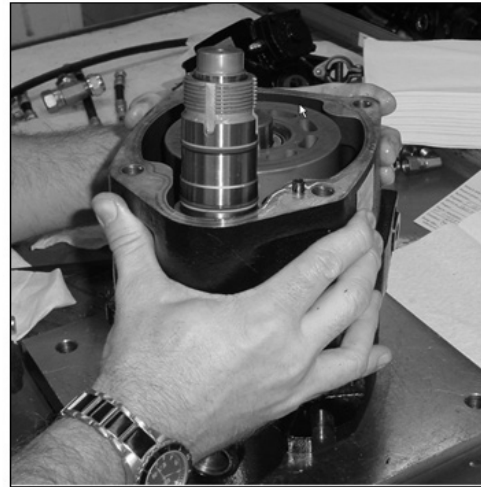

## 9. Rotating Group Removal

For fixed hold down assemblies (57cc to 141 cc):

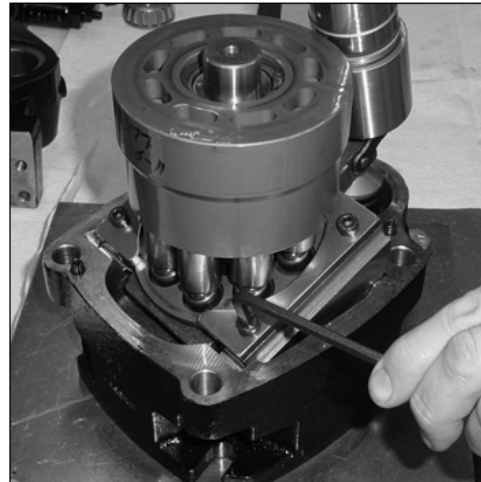

- Loosen screws first. Then remove rotating group with swash plate and control piston sub assembly.
- The complete rotating group consists of items 57 through 65.
- **WARNING: DO NOT** remove retaining ring from cylinder block because spring is under high compression. Bodily harm may result if the retaining ring is removed without adequate caution. In most cases, the parts inside the cylinder block will not require removal. However, if spring is damaged, the parts within the cylinder block must be removed.



# Disassembly



NOTE: 18cc and 45cc utilize spherical hold downs instead of fixed clearance type that are used on larger frame sizes.



- Remove Rotating group with swash plate.
- Remove 3 pins and pin retainer.
- Remove spherical seat.
- WARNING: DO NOT remove retaining ring from cylinder block because spring is under high compression. Bodily harm may result if the retaining ring is removed without adequate caution. In most cases, the parts inside the cylinder block will not require removal. However, if spring is damaged, the parts within the cylinder block must be removed.

## 10. Remove Swash Plate



Note: Swash plate must be replaced if the saddle bearings are changed

## 11. Removal of Shaft



## 12. Remove Bias Spring and Spring Guide

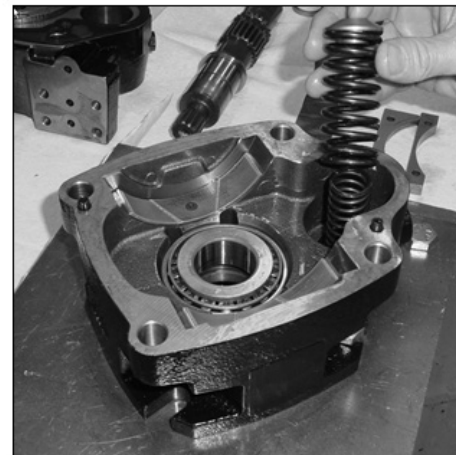

# Disassembly

## 13. Remove Shaft Bearing

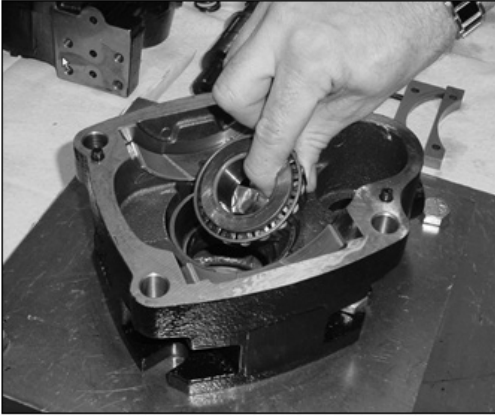

## 14. Remove Saddle Bearings

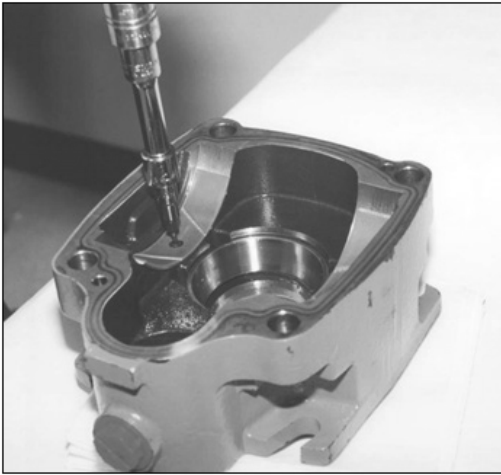

NOTE: Tap directly on the hex driver with a ball peen hammer before removing retaining screws. The screws should be discarded.

## 15. Remove Shaft Seal

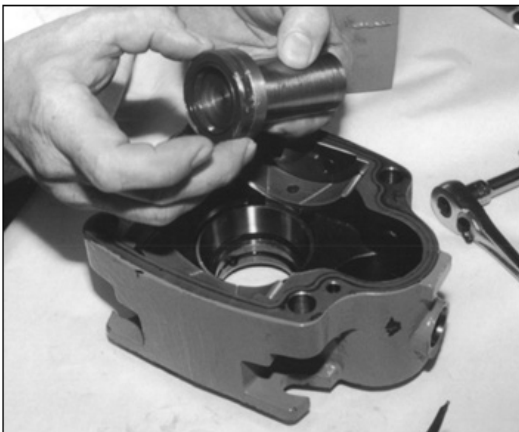

# Inspection, Repair & Part Replacement

## Inspection

Before inspection of parts, clean with a solvent that is compatible with system fluid.

### Rotating Group Parts

1. Inspect cylinder block face for wear, scratches, and/or erosion. If cylinder block condition is questionable, replace the entire rotating group.
2. Remove the pistons, shoe retainer, and pivot from piston block. The piston block assembly doesn't need to be disassembled unless the internal pins or spring are damaged.
3. Check each cylinder block bore for excessive wear. Use the piston and shoe S/A (37) for this purpose. The pistons should be a very close fit and slide in and out of the cylinder block bores. **NO BINDING CAN BE TOLERATED.** If binding occurs, clean the cylinder block and pistons. Lubricate the cylinder block bores with clean fluid and try again. Even minor contamination of the fluid may cause a piston to freeze up in a cylinder bore.
4. Inspect each of the nine piston and shoe subassemblies (31) for a maximum end play of 0.005 inch between the piston and shoe. Also check the face dimension of each shoe. The face dimension must be within 0.001 inch.
5. Inspect shoe retainer and pivot for wear and/or scratches. If condition is questionable, replace entire rotating group.



Note: Do not lap the face of piston block assembly

### Piston S/A Tolerances

This dimension must be Maintained on all nine shoes within 0.001 inch.

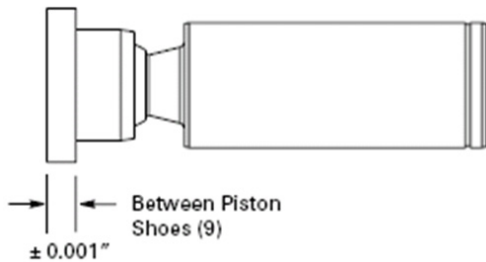

Shoe face rides on swash plate. Shoe must swivel smoothly on ball. End play must not exceed 0.005 inch.

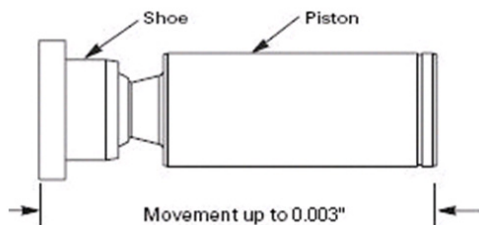



# Inspection, Repair & Part Replacement

## End Cover & Associated Parts

1. Inspect end cover for erosion, cracks and burrs. Clean up minor burrs with an India Stone. If erosion or cracks are found replace the end cover.
2. Inspect roller bearing and bearing race for nicks and pitting. Make sure the roller bearing turns freely within the bearing race. If the roller bearing needs replacement, both the roller bearing and the bearing race must be replaced.
3. Inspect valve plate for erosion, excessive wear, heavy scratches and cracks. If any of the above conditions are found, replace the valve plate.
4. Inspect control piston and maximum displacement screw for burrs, scratches and cracks. Clean up minor scratches with 500 grit paper. Remove burrs with an India stone. The control piston should move freely in the bore.

## Swash plate Parts

1. Inspect swash plate face for wear, roughness or scoring. Check the swash plate hubs and bearing surfaces for wear and cracks. Replace if defective.
2. Inspect saddle bearing surfaces for wear, pitting, and smooth operation. Replace if necessary.

## Shaft/Housing Parts

1. Inspect drive shaft for wear, stripped splines, and burrs. Remove burrs with an India stone. Inspect the contact area of bearing and shaft seal. Replace the drive shaft if wear or scoring is greater than 0.005 T.I.R. (total indicator reading).
2. Inspect drive shaft bearing for roughness, pitting of rollers and excessive end play. Replace, if defective. If the bearing needs to be replaced, the bearing race also requires replacement.
3. Inspect housing mounting flange for nicks and burrs. Remove minor nicks and burrs with an India stone. Also check the housing for damaged or stripped threads. If any thread is damaged, replace the housing.
4. Check remaining pump parts for excessive wear, damaged threads, burrs, cracks and erosion. Replace any part that is in questionable condition.

## The following should be checked regularly:

1. All hydraulic connections must be kept tight. A loose connection in a pressure line will permit the fluid to leak out. If the fluid level becomes so low as to uncover the inlet pipe opening in the reservoir, extensive damage to the pump can result. In suction or return lines, loose connections permit air to be drawn into the system resulting in noisy and/or erratic operation.
2. Clean fluid is the best insurance for long service life. Therefore, the reservoir should be checked periodically for dirt or other contaminants. If the fluid becomes contaminated, the

system should be drained and the reservoir cleaned before new fluid is added.

3. Filter elements also should be checked and replaced periodically. A clogged filter element results in a higher pressure drop. This can force particles through the filter which would ordinarily be trapped, or can cause the by-pass to open, resulting in a partial or complete loss of filtration.
4. Air bubbles in the reservoir can ruin the pump and other components. If bubbles are seen, locate the source of the air and seal the lead.

# Assembly

Assembly must be conducted in a clean environment. Dispose of leakage oil and oily cloths in an environmentally responsible manner. Before assembly process can begin, all parts have to be initially demagnetized and carefully clean all parts and blow out holes with compressed air. Tighten all screws/plugs to the specified torque (see Appendix). Exceptions are specified in the text. Lubricate O-rings and shaft sealing rings lightly with acid free lubricant for easier installation and to hold the O-ring in place in its groove or cavity.

## 1. Assembly of the Rotating Group

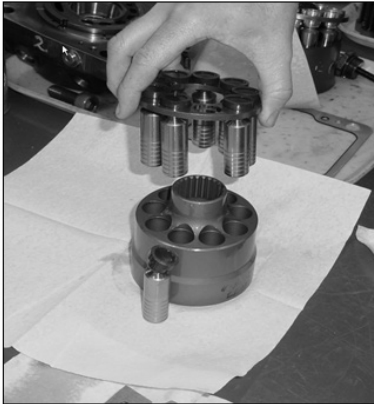

## 2. Control Sleeve and Control Piston



Note: Extreme care should be taken when installing the major and minor diameter O-rings and backup-rings. The minor OD seals are installed in reverse order to the major OD seals.

## 3. The Control Sleeve and Piston Sub-assembly to the Swash Plate

For fixed hold down assemblies (57cc to 141 cc):

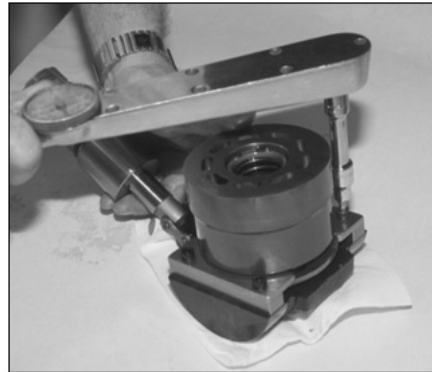
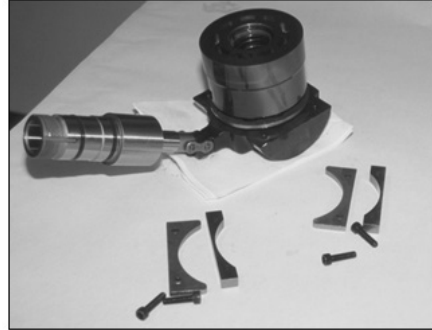

- Place the swash plate with the control piston/sleeve attached face down on the rotating group shoe faces. Invert the swash plate and rotating group, install the spacers, spacer limiter plates (bronze side towards the spacers) and retaining screws.

Note: Torque the retaining screws to the specified torque

For Spherical Hold down Assemblies (18cc and 45cc):

- Install the pin into the seat with the pin partially coming out of the flat part of the seat. Set the flat side of the seat against the swash plate and press the pin through the seat into the swash plate.



Note: The pin should be pressed flush or slightly below flush the surface of the seat. A roll pin punch or a pin setter can be used to properly position the pin into the spherical seat.

# Assembly

## 4. Flange Gasket and Alignment Pin Assembly



## 5. Install Shaft Seal and Shaft Bearing

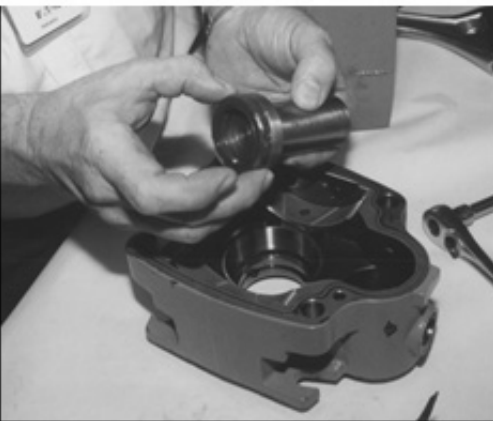

## 6. Installation of Saddle Bearings



Note: Torque retaining screws to specified torque. The bearings should be fully seated in the flange journals.

## 7. Install Bias Spring and Spring Guide

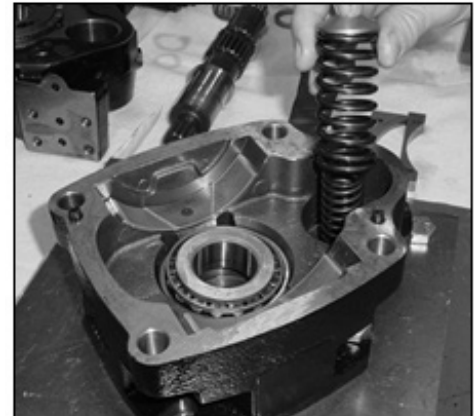

## 8. Install Shaft and Front Bearing Cone Sub-assembly in to the Flange

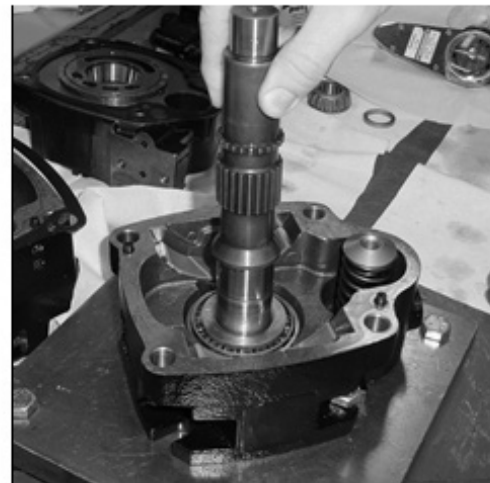

# Assembly

## 9. Installation of Swash Plate and Rotating Group

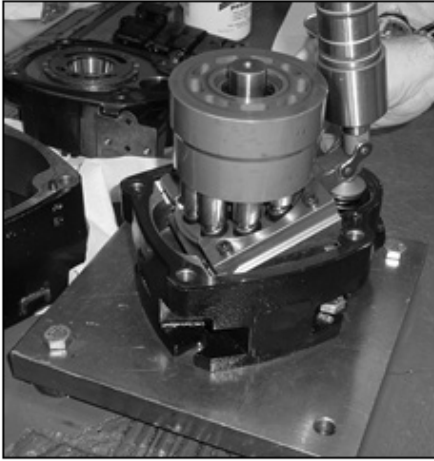

Note: The swash plate must be properly seated in the saddle bearings

## 10. Install Flange Gasket and Housing to the Flange

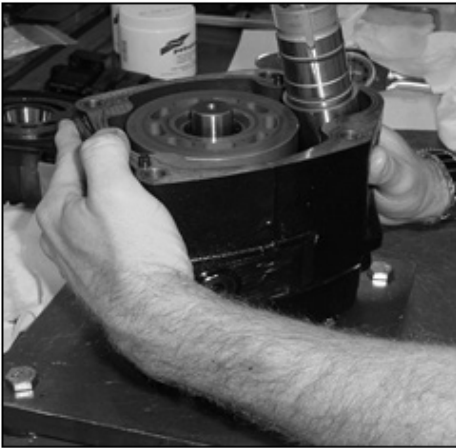

## 11. Assemble Screws Attaching Housing to Mounting Flange



## 12. Install the Shaft Bearing Spacer and Trail Bearing Cone

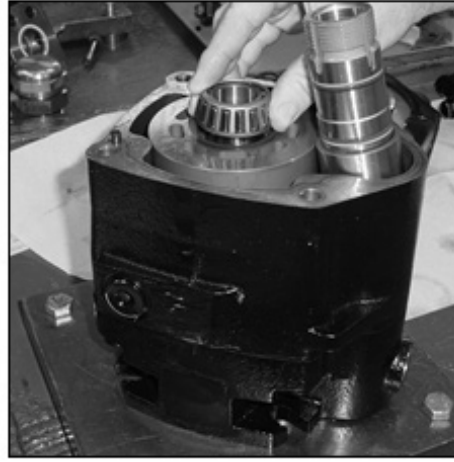

## 13. Install Valve Plate on End Cover

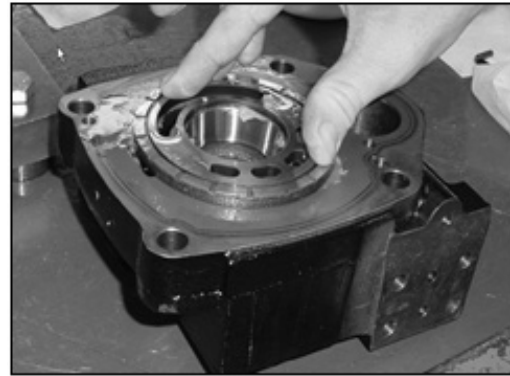

Note: Lightly coat the back plate side of the valve plate with petroleum jelly for retention during assembly. Install the valve plate over the bearing race aligning the small slot on the outside of the valve plate with the dowel pin of the back plate.

## 14. Install the End Cover Gasket

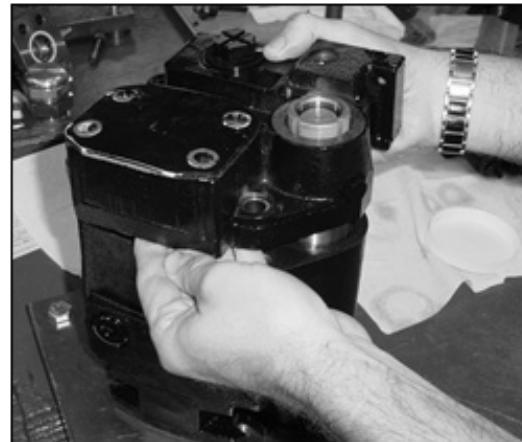



# Assembly

15. Install Alignment Pin in Control Sleeve and End Cover

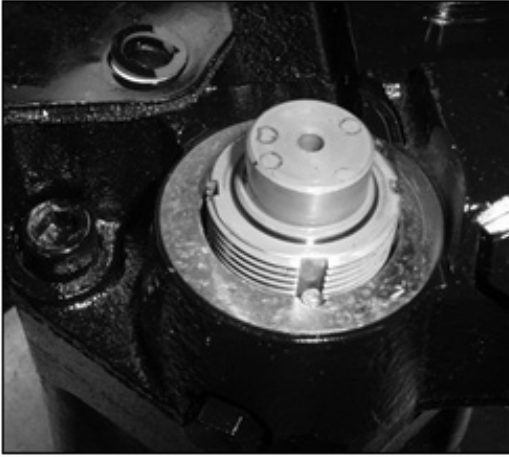

17. Install Control

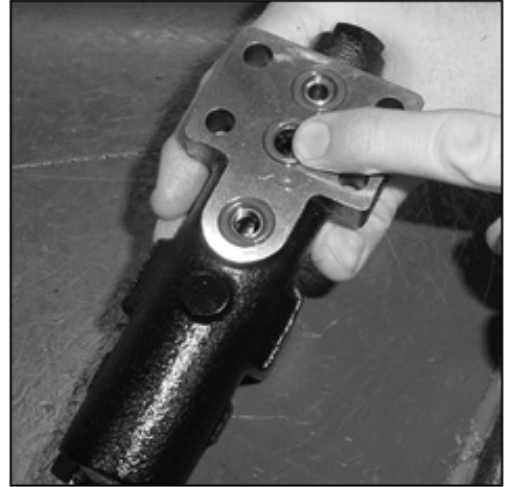

16. Install End Cover Screws

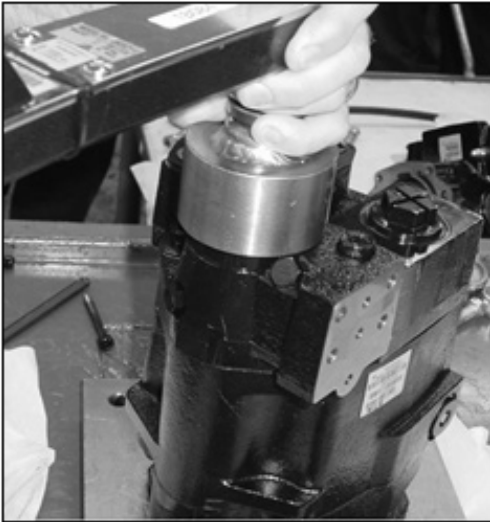

Note: Torque the control cap to the specified torque.

# Testing

## Start-up Procedure

Make sure the reservoir and circuit are clean and free of dirt/debris prior to filling with hydraulic fluid. Fill the reservoir with filtered oil to a level sufficient to prevent vortexing at suction connection to pump inlet. It is good practice to clean the system by flushing and filtering using an external slave pump. Before starting the pump, fill with fluid through one of the ports. This is particularly important if the pump is above the fluid level of the reservoir. When initially starting the pump, remove all trapped air from the system. This can be accomplished by loosening the pump outlet fittings or connections before starting the pump or by using an air bleed valve. All inlet connections must be tight to prevent air leaks. Once the pump is started it should prime within a few seconds. If the pump does not prime, check to make sure that there are no restrictions between the reservoir and the inlet to the pump, and there are no air leaks in the inlet line and connections. Also check to make sure that trapped air can escape at the pump outlet. After the pump is primed, tighten the loose outlet connections, and then operate for five to ten minutes (unloaded) to remove all trapped air from the circuit. If reservoir has a sight gauge, make sure the fluid is clear – not milky. Add fluid to the reservoir up to the proper fill level. Perform functional test on pump according to Eaton test procedure. Contact your area sales manager for more information.

## Troubleshooting

The troubleshooting chart below lists common difficulties experienced with pumps and hydraulic systems. The chart indicates probable causes and remedies for each of the troubles listed.

<b>Trouble</b>	<b>Probable Cause</b>	<b>Remedy</b>
Excessive noise in pump	low oil level in reservoir	fill reservoir to proper level with recommended fluid. DO NOT overfill or damage may result.
	Air in the system	<ol style="list-style-type: none"> <li>1. Open reservoir cap and operate hydraulic system until purged.</li> <li>2. "Bleed" hydraulic lines at point downstream of the pump while the system is under pressure.</li> </ol>
	Vacuum condition	Check inlet (suction) lines and fittings for leaks.
Hydraulic pump over heating	Oil too thick	Be certain correct type of oil is for refilling or adding to the system.
	Cold weather	Run hydraulic system until unit is warm to the touch and noise disappears.
	Internal leakage	If established that excessive internal leakage exist within the pump, return to maintenance shop for evaluation and repair.
System not developing pressure	Heat exchanger not functioning	Locate trouble and repair or replace.
	Fluid level low	Add oil to proper operating level.
	Compensator malfunction	Replace or repair.
Loss of fluid	Loss of fluid internally (slippage)	Return to maintenance shop for evaluation and repair.
	Ruptured hydraulic line	<ol style="list-style-type: none"> <li>1. Check all external connections, tubing and hoses.</li> <li>2. Tighten connections, replace ruptured tube or hose.</li> </ol>
Miscellaneous	Leaking gaskets or seals in the system	Observe mating section of pump for leaks. Replace seals or gaskets in possible. Check all system components for leaks.
	Broken or mis-adjusted pump control	Adjust or replace pump control.
	Disconnected or broken drive mechanism	Locate and repair.

# Assembly Torque Values

BOM Part No	Part Name	Torque Value
2	Soc HD Cap Screw M5	7.4 To 9.0 Nm
22	O-Ring Plug S/A	See Table
25, 26	O-Ring Plug S/A	See Table
27	Soc HD Cap Screw	See Table
32	Control Cap	See Table
35	Jam Nut	See Table
51	Screw Socket Flat Head	3.6 To 4.4 Nm
70	Screw	63 To 77 Nm

Torque Rating for Plugs and Fasteners				
Pump Size	Item 22 & 84	Item 26	Item 27	Item 32
PVM 18/20	60 - 64 N.m	60 - 64 N.m	59 - 73 N.m	185 - 205 N.m
PVM 45/50	75 - 83 N.m	23 - 26 N.m	103 - 127 N.m	210 - 230 N.m

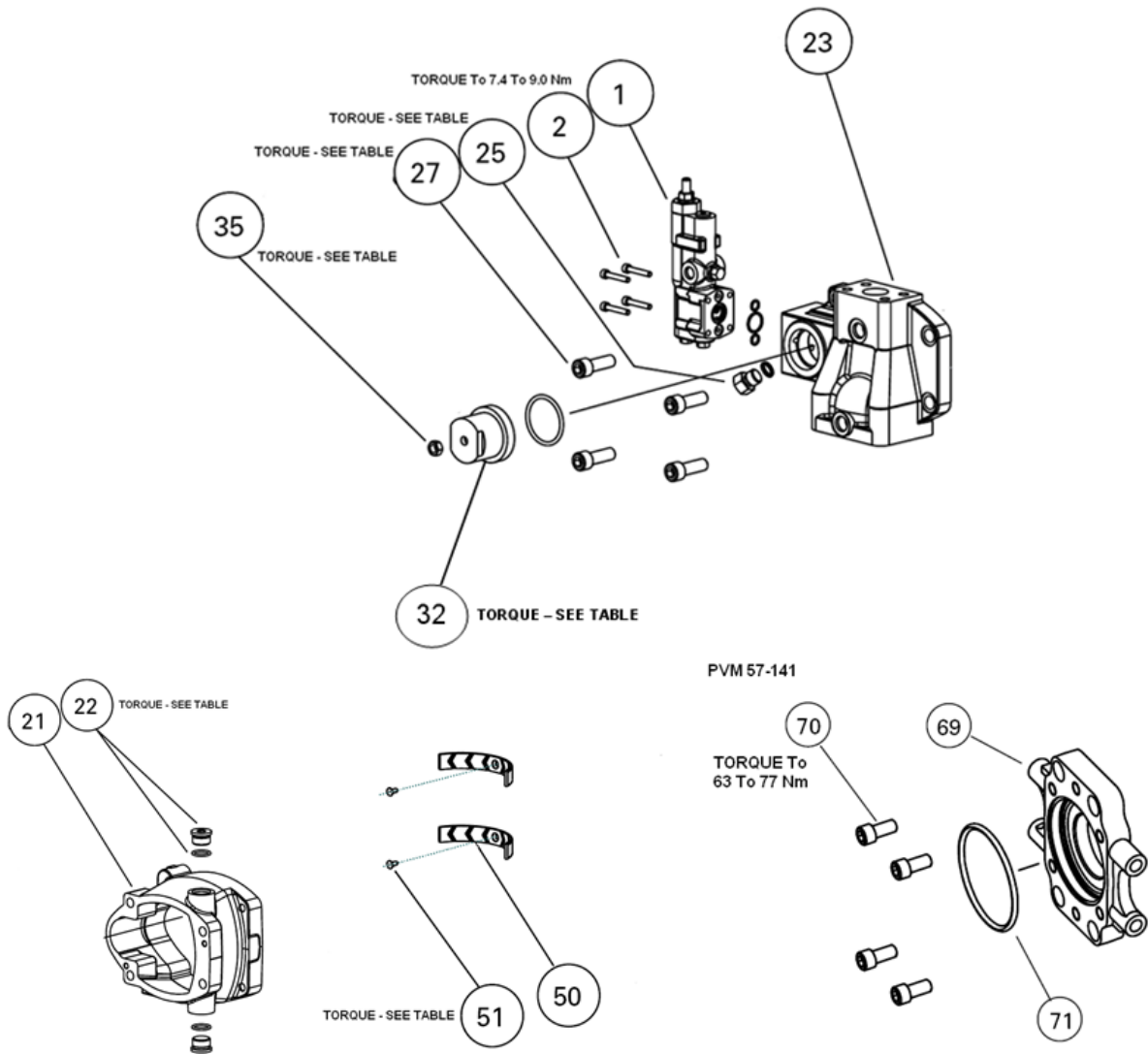

Torque Rating for Plugs and Fasteners							
	Item 12	Item 25	Item 27	Item 28	Item 32	Item 68	Item 35
PVM 57/63	103-127 N.m	15-16 N.m	103-127 N.m	103-127 N.m	260-300 N.m	13-15 N.m	18-24 N.m
PVM 74/81	103-127 N.m	15-16 N.m	257-315 N.m	N/A	260-300 N.m	13-15 N.m	24-30 N.m
PVM 98/106	103-127 N.m	15-16 N.m	257-315 N.m	257-315 N.m	260-300 N.m	31-37 N.m	24-30 N.m
PVM 131/141	157-315 N.m	N/A	257-315 N.m	257-315 N.m	260-300 N.m	31-37 N.m	24-30 N.m

Eaton  
Hydraulics Group USA  
14615 Lone Oak Road  
Eden Prairie, MN 55344  
USA  
Tel: 952-937-9800  
Fax: 952-294-7722  
[www.eaton.com/hydraulics](http://www.eaton.com/hydraulics)

Eaton  
Hydraulics Group Europe  
Route de la Longeraie 7  
1110 Morges  
Switzerland  
Tel: +41 (0) 21 811 4600  
Fax: +41 (0) 21 811 4601

Eaton  
Hydraulics Group Asia Pacific  
Eaton Building  
No.7 Lane 280 Linhong Road  
Changning District, Shanghai  
200335 China  
Tel: (+86 21) 5200 0099  
Fax: (+86 21) 2230 7240