

NO. 7-403

**Eaton  
Hydraulics  
Division**

# Repair Information

---

**Eaton Hydrostatic Transmissions – Model 6/7**

---

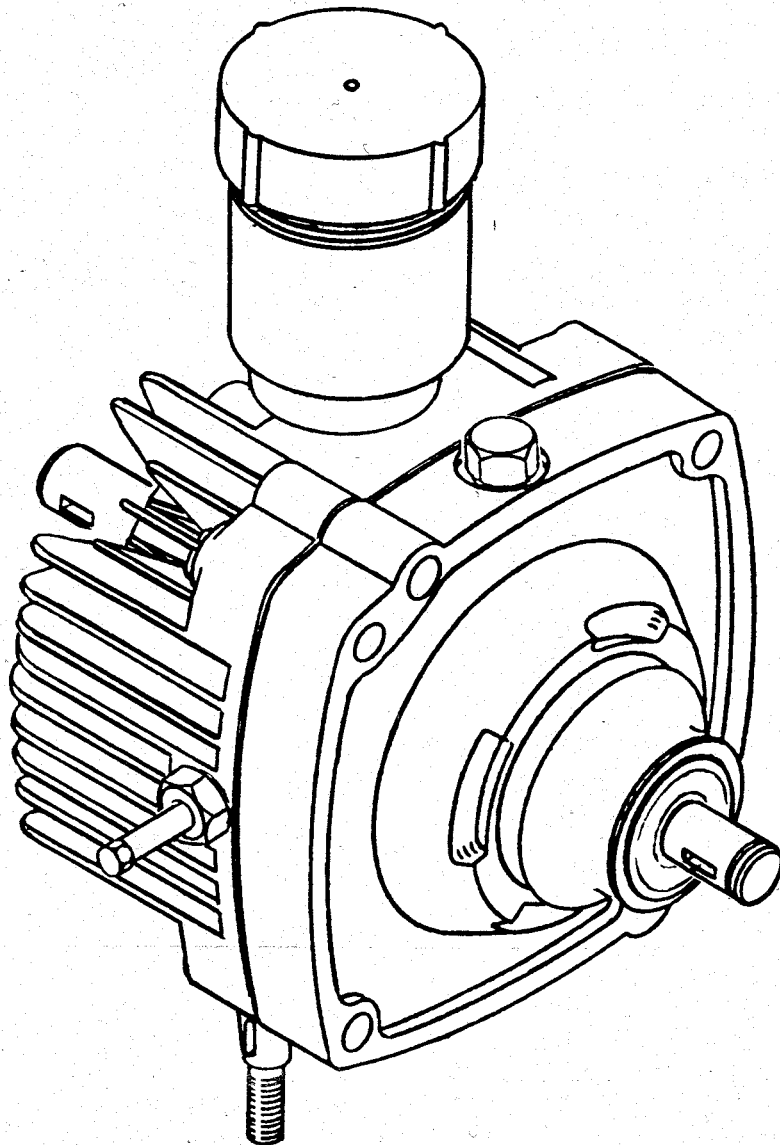

**EATON**

2

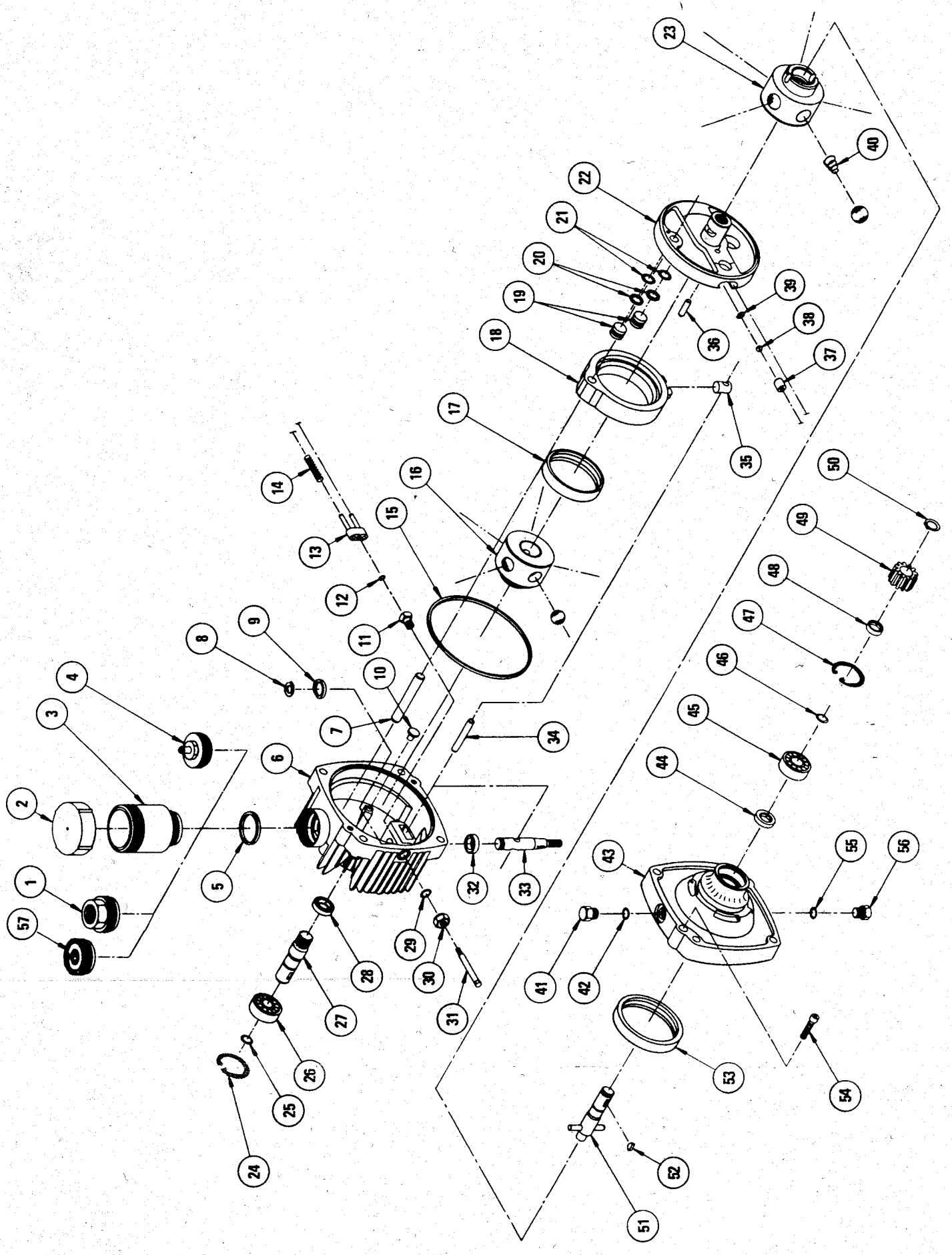

# General Parts List Model 6 and 7

Item No.	Description	Item No.	Description
1	Reservoir Adapter	30	Nut and Gasket Subassembly
2	Reservoir Cover Subassembly	31	Dump Valve Shaft
3	Reservoir Body	32	Seal
4	Reservoir Adapter	33	Control Shaft Kit
5	Seal Ring	34	Dowel
6	Cover Service Kit	35	Cam Ring Insert
7	Dowel Pin	36	Pin
8	Retaining Ring	37	Check Valve Body
9	Washer	38	Ball
10	Button (Model 7 only)	39	Retaining Ring
11	Guide Fitting Subassembly	40	Spring
12	O-Ring	41	Plug Subassembly
13	Dump Valve Bracket	42	O-Ring
14	Spring	43	Body
15	Seal Ring	44	Seal
16	Pump Rotor and Ball Assembly	45	Bearing
17	Pump Race	46	Snap Ring
18	Cam Ring Assembly (includes No. 17)	47	Retaining Ring
19	Piston (Model 7 only)	48	Spacer
20	Back-Up Ring (Model 7 only)	49	Gear
21	O-Ring (Model 7 only)	50	Retaining Ring
22	Pintle Subassembly	51	Output Shaft Subassembly
23	Motor Rotor and Ball Assembly	52	Key
24	Retaining Ring	53	Motor Race
25	Snap Ring	54	Cap Screw
26	Bearing	55	O-Ring
27	Input Shaft	56	Plug Subassembly
28	Seal	57	Plug
29	O-Ring		

This list is for identification of parts only. To insure the correct replacement parts for your transmission, it will be necessary to order parts by part number. Consult your supplier for a parts list for your specific model number.

## Contents

<b>Product Identification and Ordering Information</b>	4
<b>Exploded View</b>	2
<b>Part Description</b>	3
<b>Disassembly—Reassembly Procedures</b>	
<b>Body Assembly—Disassembly</b>	9
<b>Reassembly</b>	11
<b>Body/Cover—Disassembly</b>	5
<b>Reassembly</b>	11
<b>Cam Ring—Disassembly/Inspection</b>	6
<b>Installation</b>	11
<b>Check Valves—Removal</b>	7
<b>Installation</b>	8
<b>Cover Assembly—Disassembly/Inspection</b>	5
<b>Reassembly</b>	9
<b>Dampening Pistons—Removal</b>	8
<b>Installation</b>	8
<b>Motor Rotor Assembly—Removal</b>	8
<b>Installation</b>	12
<b>Pintle Assembly—Removal</b>	7
<b>Disassembly/Inspection</b>	7
<b>Installation</b>	11
<b>Pump Rotor Assembly—Removal</b>	7
<b>Installation</b>	11
<b>Reservoir/Adapter—Disassembly</b>	5
<b>Reassembly</b>	13
<b>Rotor Assemblies—Disassembly/Inspection</b>	8
<b>Start/up Procedures</b>	13
<b>Trouble Shooting</b>	14
<b>Fluid Recommendations</b>	16

## Product Identification and Ordering Information

Refer to specific listing covering your Eaton transmission. Parts listings are available from the Hydraulics Division, Minneapolis Plant.

When ordering parts, please include the following:

- Model Number
- Date Code
- Part Number
- Part Name
- Quantity of Parts

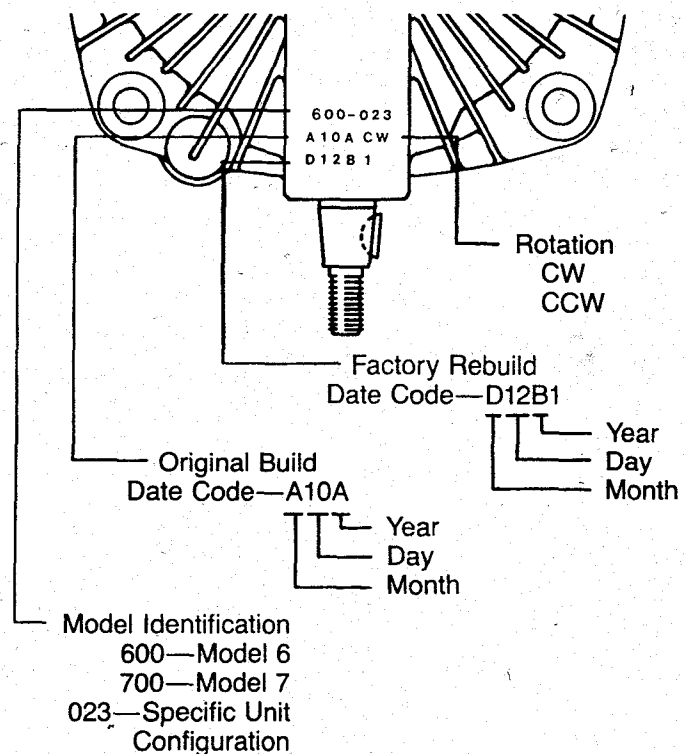

## Special tools to aid in Disassembly/Reassembly

2" x 6" x 10" wooden block with 3/4" dia. hole in the center.

2 large, wide rubber bands.

5/16-18 tap.

Light petroleum jelly (such as Vaseline).

Steel bar stock or piece of wood—2" dia. x 2 1/2" long.

## Disassembly/Reassembly

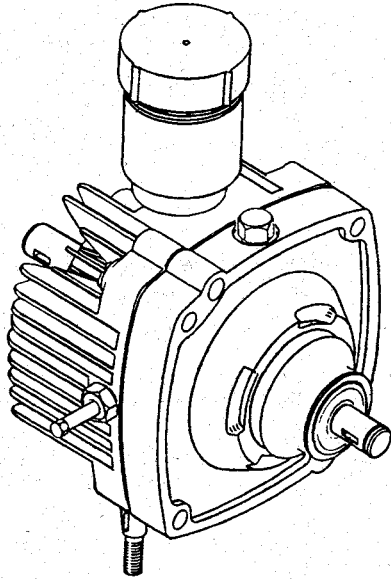

Fig. 1

Clean the transmission exterior thoroughly before repairs are begun. Use a cleaning solution that will not affect paint, gaskets, rubber seals, and plastic.

**Important:** When compressed air is used in cleaning, do not expose lip seals or bearing surfaces to high pressure.

Drain fluid from transmission.

**Note:** A 2" x 6" x 10" wooden block with a 3/4 inch hole in the center is recommended for a suitable bench fixture.

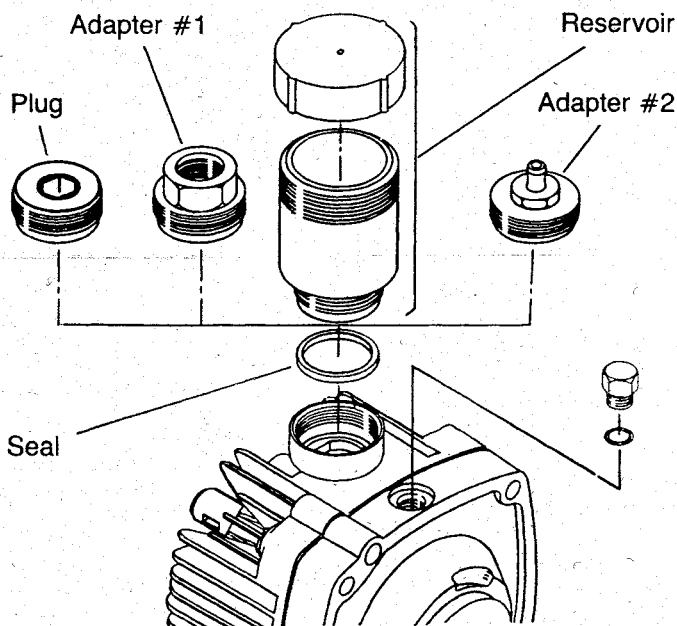

Fig. 2

## Reservoir/Adapter—Disassembly

Eaton light duty transmissions are equipped with one of two adapters or a reservoir as shown in Fig. 2.

1 Remove the adapter or reservoir by rotating *clockwise*.

**Important:** The adapters and reservoir have left hand threads. To remove turn *clockwise*.

To remove adapter #1 use a six point 1 1/2" hex wrench or socket.

To remove adapter #2 use a six point 1" hex wrench or socket.

To remove the reservoir use a small filter or web wrench.

2 Remove the seal ring from the cover and discard.

**Note:** We recommend that all seals be replaced with new ones whenever the transmission is disassembled and reassembled.

## Body/Cover—Disassembly

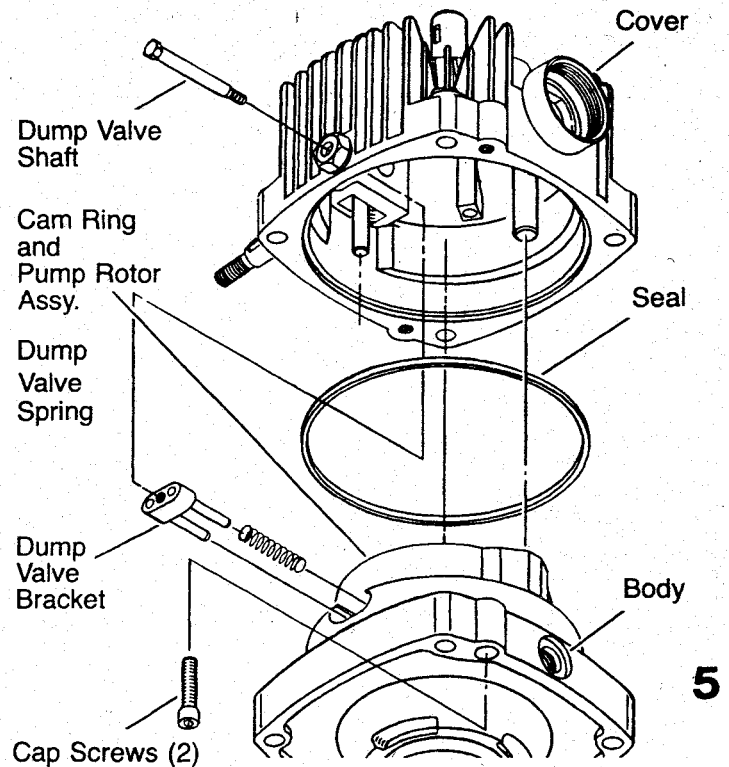

Fig. 3

**Important:** Before disassembling the transmission, scribe a line across the cover and body to ensure correct reassembly. Incorrect assembly will change output shaft rotation.

3 Use 1/4 inch allen wrench to remove the (2) 5/16 cap screws. Where applicable, remove the dump valve shaft.

4 Lift the cover to separate from the body.

**Important: Do not allow the cam ring, pintle, or pump rotor assembly to lift with the cover. The pump ball piston assembly must remain intact as the ball pistons are matched to the pump rotor bores.**

If the cover does not separate easily from the body because of fluid seal, tap the body and or cover with plastic hammer to break the seal.

5 Remove the dump valve bracket, and springs, when used.

6 Remove the seal ring and discard.

### Cover—Disassembly

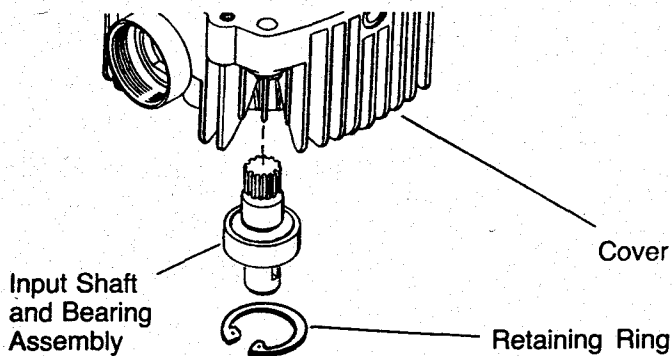

Fig. 4

7 Remove input shaft retaining ring. Press or drive the input shaft and bearing assembly from the cover.

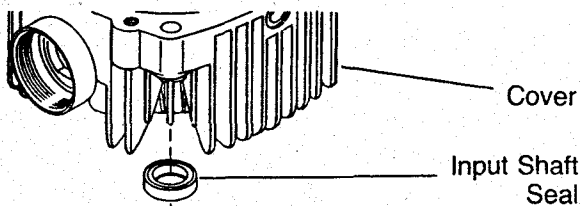

Fig. 5

6 8 Press or drive the input shaft seal from the cover.

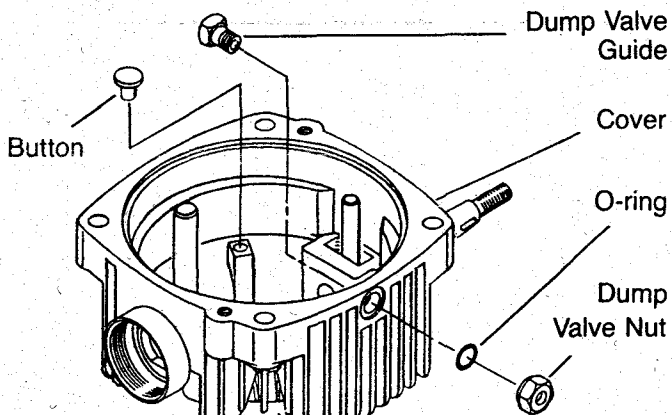

Fig. 6

9 Remove the button from the cover (model 7 only).

Where applicable, remove the dump valve guide, nut, and o-ring. Discard the o-ring.

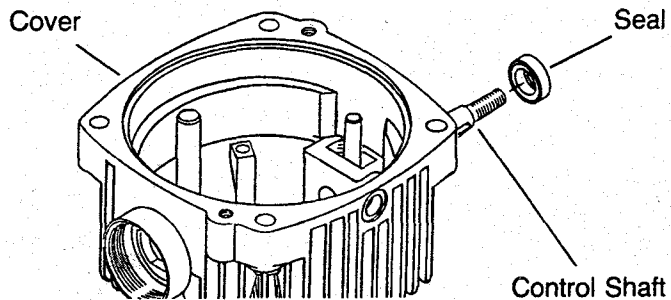

Fig. 7

10 Use a sharp, narrow tool to pierce the top metal part of the oil seal and remove seal from the cover.

**Important: Do not scratch the control shaft or distort the seal counter bore when removing seal.**

### Cam Ring—Disassembly/Inspection

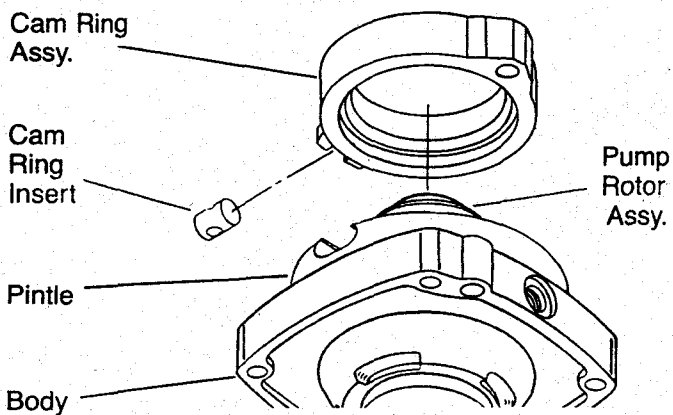

Fig. 8

11 Remove the cam ring assembly from the pintle. Remove the cam ring insert.

**Important: Use special care when removing the cam ring from the pump rotor assembly. The ball pistons must remain in place as they are matched to the rotor bores. Use a wide rubber band to hold the ball pistons in place.**

12 Inspect area where the ball pistons contact the pump race. This area must be smooth and completely free of irregularities. If it is not, replace the pump race.

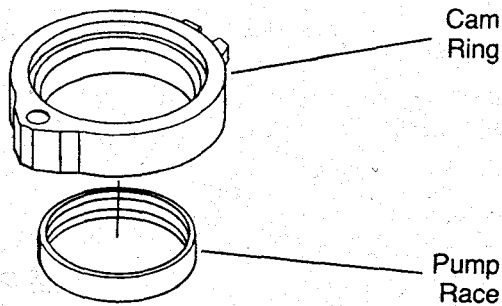

Fig. 9

**Note:** The pump race is press fit in the cam ring and will require a press to remove it. The cam ring and pump race are available as an assembly.

**Note:** If irregularities are noted in the pump race, it is reasonable to assume that one or more ball pistons and rotor bores will also be damaged.

### Pump Rotor—Removal

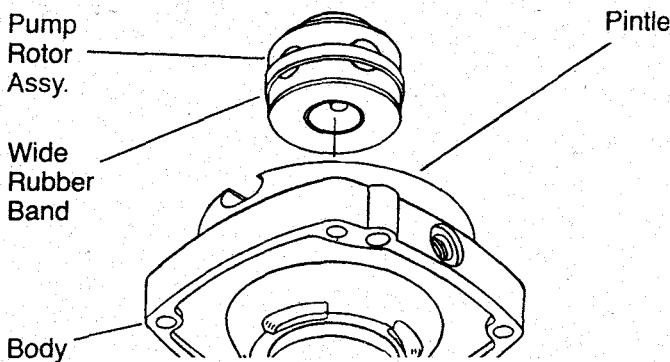

Fig. 10

13 Hold the pintle assembly in position against the body and remove the pump rotor assembly intact.

### Pintle Assy.—Removal

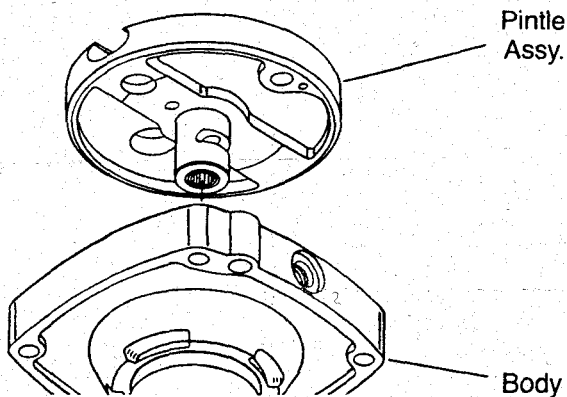

Fig. 11

14 Hold the motor rotor assembly in the bottom position and tap lightly on the body. Lift the pintle assembly out of the body.

### Pintle Assembly—Disassembly/Inspection

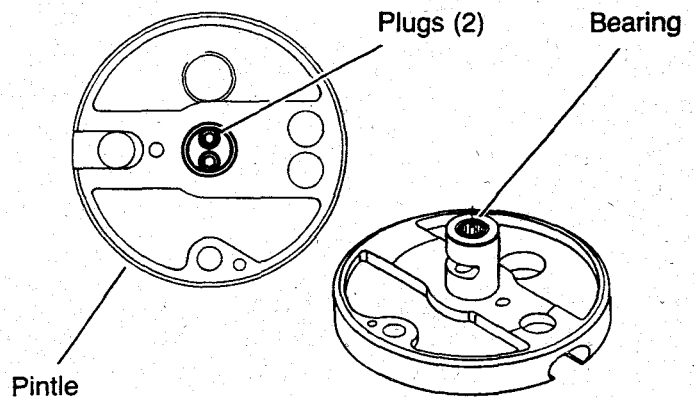

Fig. 12

15 We do not recommend complete disassembly of the pintle assembly for cleaning. Normal flushing should be all that is required. However, if complete disassembly is required, use the following procedures:

**Note:** Do not remove the two large plugs located on pintle journal.

16 Inspect the pintle journals, particularly in the porting area for any irregularities such as scoring or grooves cut between ports.

If any irregularities are noted: Replace the pintle assembly.

### Check Valve—Removal

**Note:** Removal of check valves is not necessary if check valve balls move freely and seat properly.

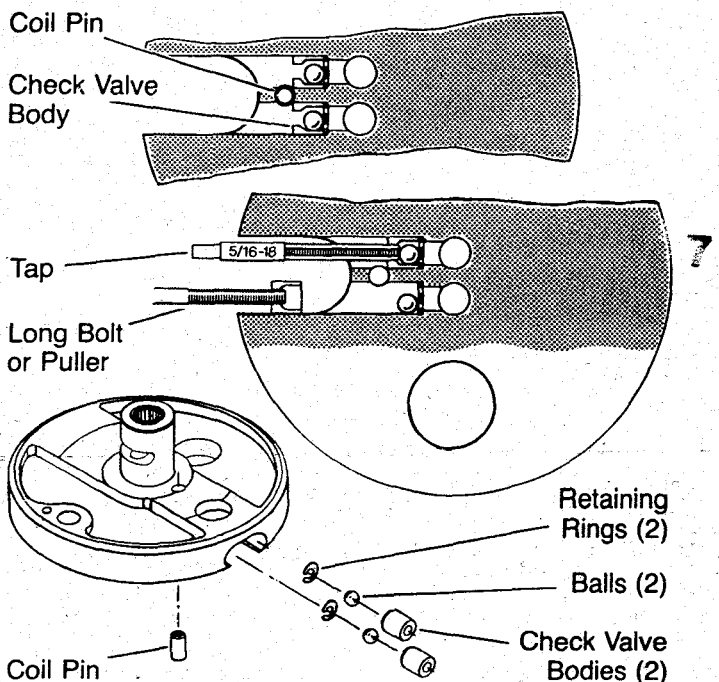

Fig. 13

17 Press or drive out the coil pin that retains the two check valve bodies. Use a four blade  $\frac{5}{16}$ -18 tap to tap holes in check valve bodies. Insert a long bolt or a threaded puller, pull the check valve bodies from the pintle housing and discard them.

18 Remove check balls and retaining ring.

19 Inspect check valve balls and retaining rings. Replace any defective parts.

### Check Valve—Installation

20 Install retaining rings and check valve balls in bores of pintle. Press *new* check valve bodies in bores. Press far enough for coil pin clearance.

**Important:** To prevent dislodging of retaining rings **do not drive check valve bodies into bores.**

21 Press coil pin into pintle until flush with or slightly below surface.

### Dampening Piston—Removal (Model 7 Only)

**Note:** Remove only if surface is scored.

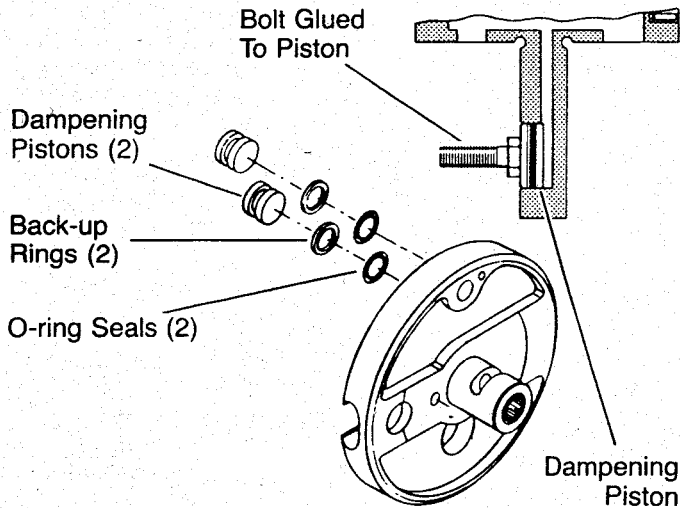

Fig. 14

22 To remove pistons, firmly tap the outside edge of pintle on a work surface. Remove back-up ring and o-ring from pistons.

**Important:** When dislodging dampening pistons, **do not hit pintle journals or the pintle housing will be ruined.**

**Note:** If tapping of pintle does not dislodge the pistons, use adhesive to cement a bolt or similar object to the pistons and pull them from the bore.

### Dampening Piston—Installation

23 Install new back-up rings nearest to the smooth piston face and o-rings in groove on a new piston.

24 Lubricate outer surface of the pistons. Press pistons (smooth face up) in bores in pintle to the bottom position.

### Motor Rotor—Removal

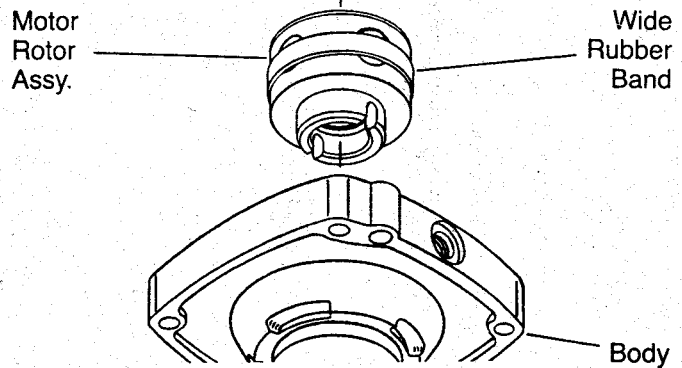

Fig. 15

25 Remove the motor assembly intact from the body.

**Important:** Use special care when removing the motor rotor from the body. The ball pistons **MUST** remain in place as they are matched to the motor bores. Use a wide rubber band to hold the ball pistons in place.

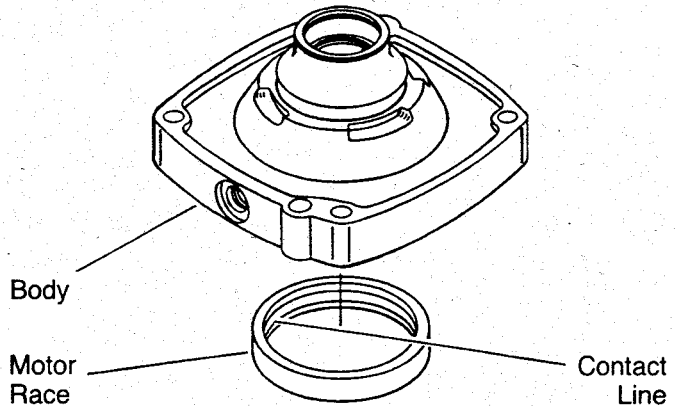

Fig. 16

26 Inspect the contact line of the motor ball pistons on the motor race located in body. This contact area must be smooth and completely free of any irregularities. If any irregularities are noted, replace the motor race.

**Note:** If irregularities are noted in the motor race, it is reasonable to assume that one or more ball pistons and rotor bores will also be damaged.

### Rotor Assemblies—Disassembly Inspection



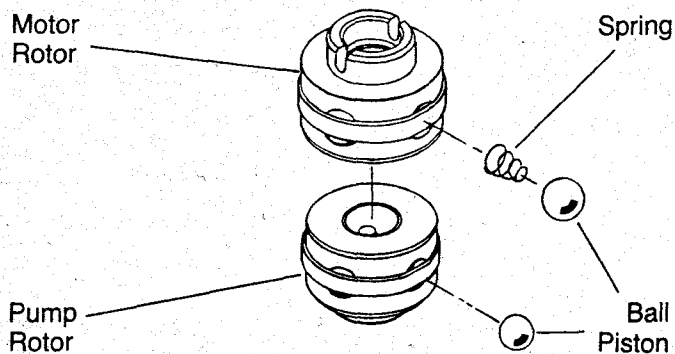

Fig. 17

**27** Inspect the rotor assemblies. Remove the piston balls from the rotor, one at a time, by working clockwise from the letter stamped in the face of the rotor and placing in a prepared container.

**Note:** Each ball must be replaced in the same bore from which it was removed. Use a suitable container for piston ball storage such as an egg carton or ice cube tray.

**28** Inspect for broken or collapsed springs in the motor rotor assembly.

**Note:** When broken or collapsed springs are found with no other irregularities, the springs may be replaced individually without replacing the complete motor rotor assembly.

**29** Inspect the piston balls. They must be smooth and completely free of any irregularities.

**30** Inspect the rotor bores, rotor bushing and pintle journals for irregularities or excessive clearance. The ball piston to rotor bore clearance is select fit electronically to .0002 to .0006 of an inch. When irregularities or excessive clearance are noted, replace the complete rotor assembly.

Install ball pistons in their matching bores. Hold them in place with a rubber band.

### Body—Disassembly

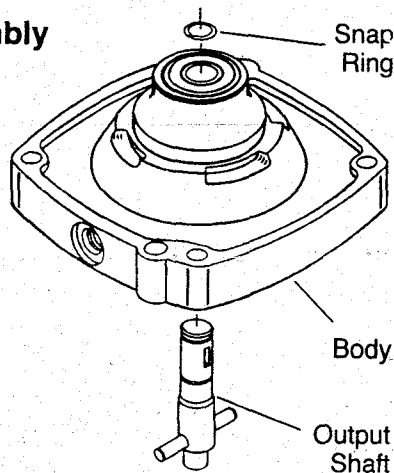

Fig. 18

**31** Remove the snap ring that retains the output shaft and tap or press the shaft from the body.

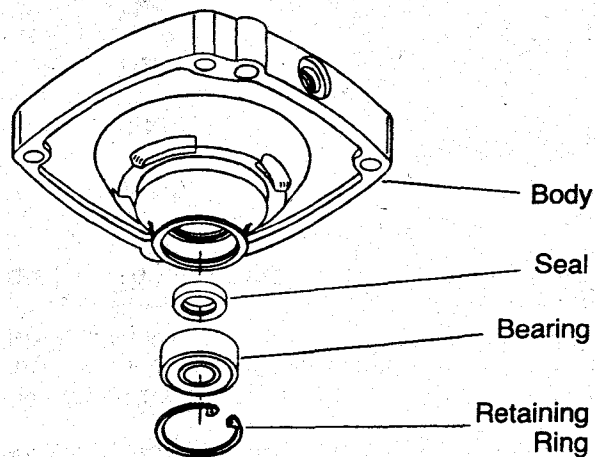

Fig. 19

**32** Remove the large retaining ring that retains the output bearing to body. Drive or press the output bearing and seal from the motor body.

### Cover—Reassembly

**33** Inspect cover assembly, especially around the control shaft area. Replace the cover assembly if it is broken, cracked or if side clearance between control shaft and cover exceeds .006".

**34** In most cases, it will not be necessary to remove the control shaft from the cover. If the dowel is loose or broken in the control shaft, remove the shaft using the following procedures.

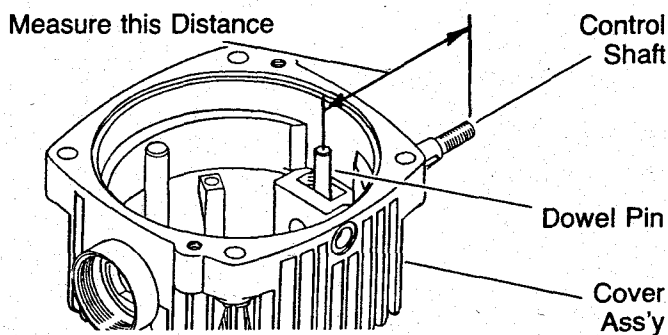

Fig. 20

**35** Measure the distance between center of dowel pin and the end of the shaft as shown in Figure 20.

**36** Turn cover over. Use this dimension to locate dowel pin in cover face. Drill  $1\frac{1}{32}$ " diameter hole at center point of dowel pin. Drill hole exactly in line with center of shaft.

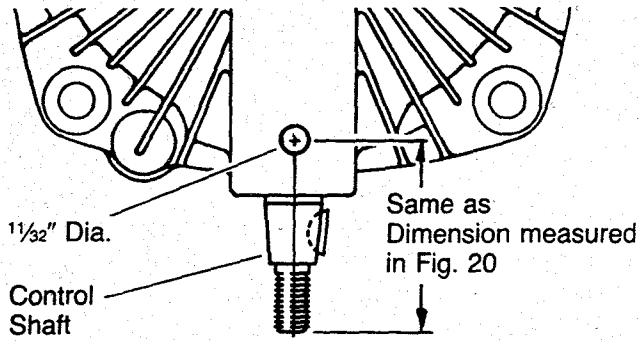

Fig. 21

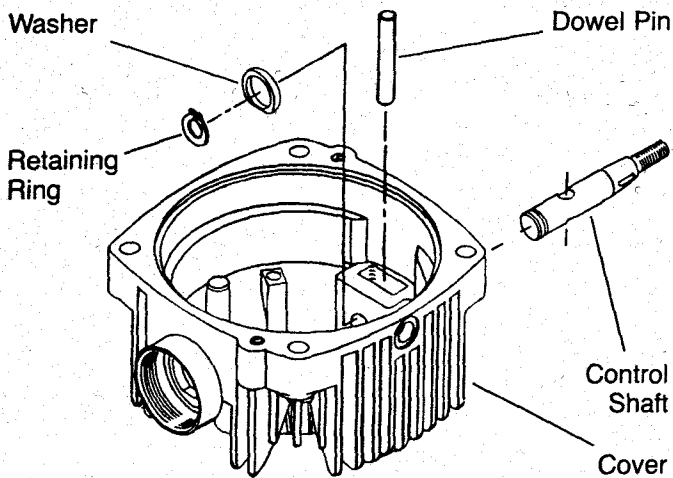

Fig. 22

37 Press loose or broken dowel pin out. Remove retaining ring and washer from end of control shaft. Remove control shaft outward from the cover.

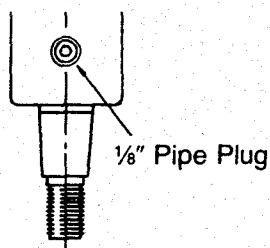

Fig. 23

38 Tap hole drilled with 1/8" pipe tap. Install 1/8" flush type pipe plug.

39 Lubricate a new control shaft and install in cover. Replace washer and retaining ring on end of control shaft. Press new dowel pin through shaft leaving 1 1/8 inch of dowel extending from shaft.

**Important:** When pressing the new dowel pin into the control shaft, the Woodruff key in control shaft must be to the left looking at the threaded end of shaft.

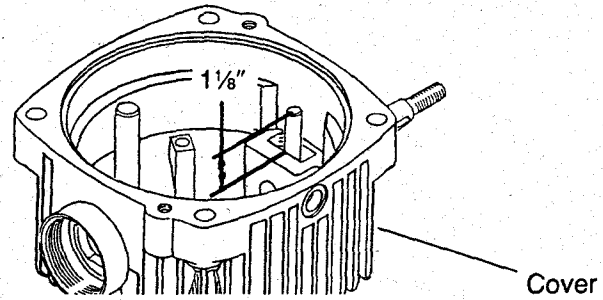

Fig. 24

40 Lubricate I.D. of new oil seal with clean lubricant. Then press or tap seal in bore until completely seated.

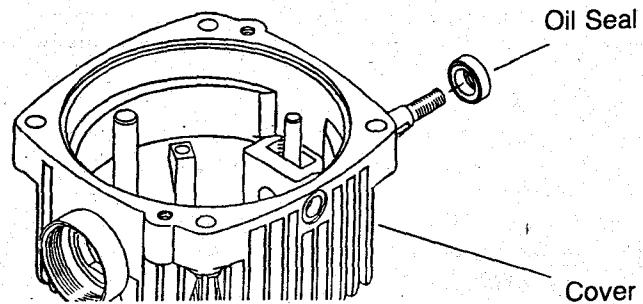

Fig. 25

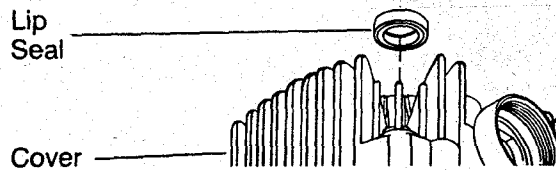

Fig. 26

41 Lubricate inner surface of the lip seal with a clean lubricant. Press or tap seal into the bottom position in cover counter bore.

**Important:** Be careful not to damage the inner portion of the oil seal. Excessive pressing or driving of the oil seal will damage the rubber portion of the seal.

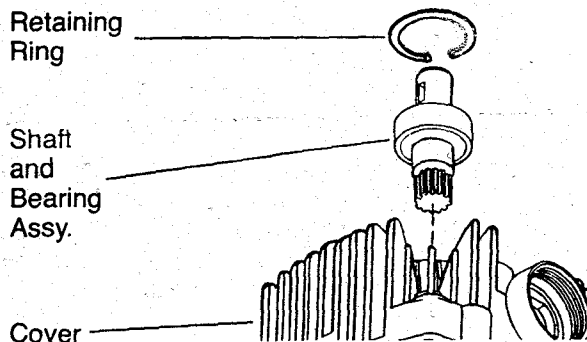

Fig. 27

42 Install the input shaft assembly into bottom position in the counter bore in cover. Install the retaining ring in the groove located in front cover.

### Cam Ring—Installation

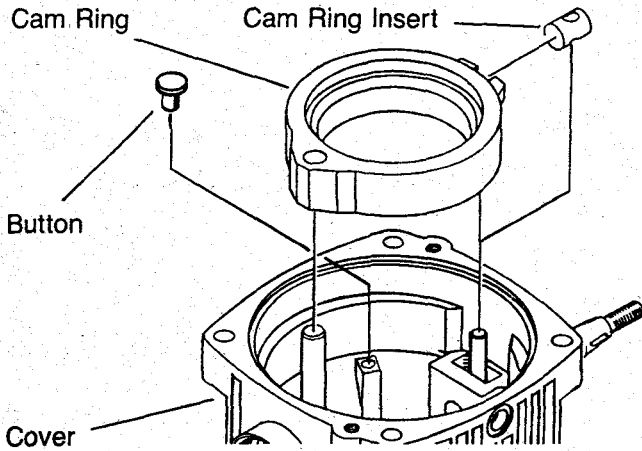

Fig. 28

43 Install the button in the hole located in the cover. (In Model 7 only)

44 Install the cam ring insert with the hole away from the cam ring as shown in Figure 28.

45 Align the cam ring with the control shaft pin and the cam ring pivot pin.

Install the cam ring with the flush side of the bearing race facing the cover. Press in firmly until the cam ring has bottomed in the cover assembly.

**Important: Cam ring must move freely from stop to stop. If binding occurs at either stop rotate the cam ring insert 180°. Check the cam ring movement again.**

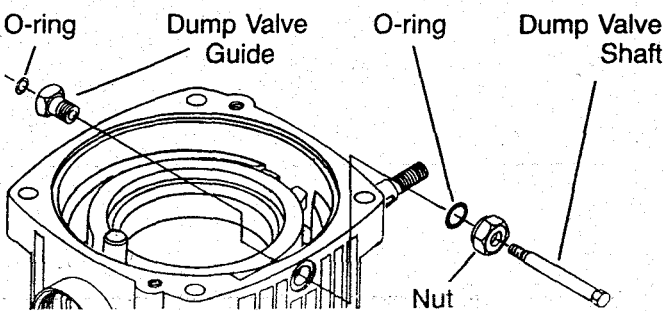

Fig. 29

46 Where applicable, lubricate O-Ring and install in groove located in dump valve guide. Install guide through cover and install O-Ring and nut. Lubricate dump valve, valve shaft and install in guide assembly.

**Note:** Check dump valve shaft for freedom of movement.

### Pump Rotor-Installation

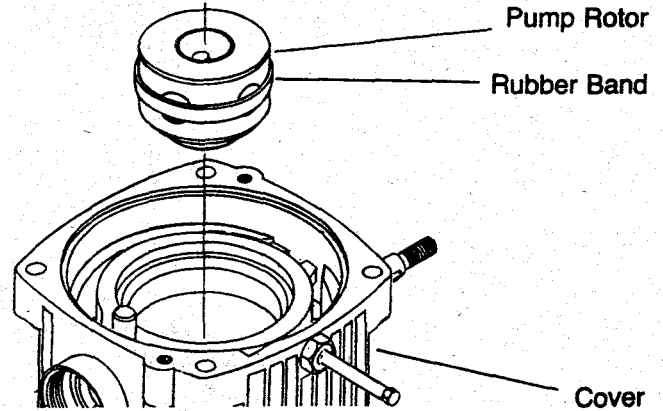

Fig. 30

47 Align the internal spline in the pump rotor assembly with the external spline on the input shaft and install the pump rotor in the cover.

Remove the rubber band retaining the ball pistons (if used).

### Pintle—Installation

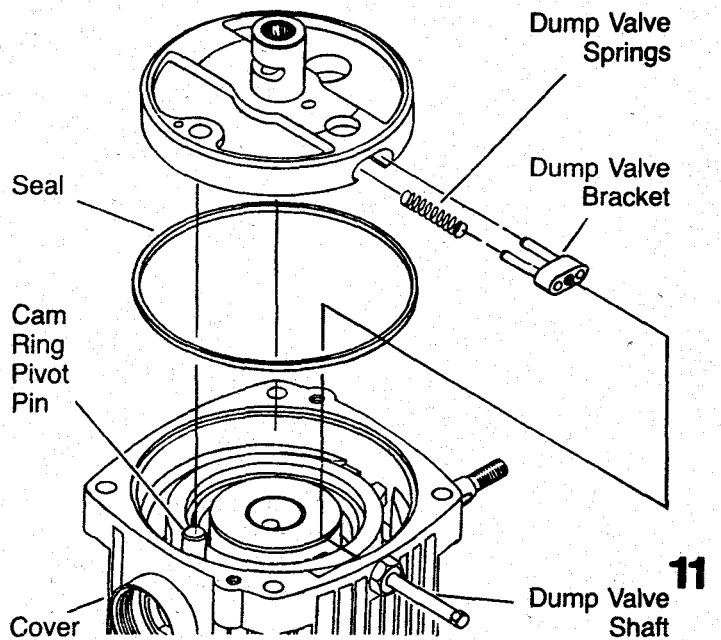

Fig. 31

48 Install the two springs and dump valve bracket into pintle assembly.

Use a small screwdriver to compress and hold dump valve bracket into pintle to clear previously installed dump valve guide located in cover.

49 Align pintle assembly with the cam ring pivot pin and guide pintle assembly into pump rotor. Push to bottom position in cover.

**Note:** Do not force pintle through the pump rotor assembly as it is a slip fit. The pump rotor assembly must turn freely on the pintle by hand. If not recheck pintle installation.

**50** Push dump valve shaft in and thread into dump valve bracket. **Torque to 2-3 Foot Pounds.**

**51** Lightly grease new cover sealing ring and install in the groove in the cover.

**Body—Reassembly**

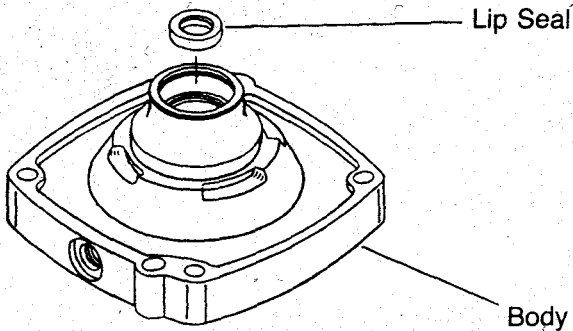

Fig. 32

**52** Lubricate inner surface of new lip seal and install with the rubber lip of the seal toward the counter bore in body.

**Important:** Do not over press or drive the seal, this may damage the rubber sealing portion of the seal or distort counter bore.

**53** Install output shaft into body, protecting the shaft seal lip from keyway and snap ring grooves.

Support the output shaft from underneath body so that the cross pin in output shaft is tight against body.

Use a solid block (steel or hardwood) 2 inches in diameter by at least 1½ inches long to support the output shaft.

12

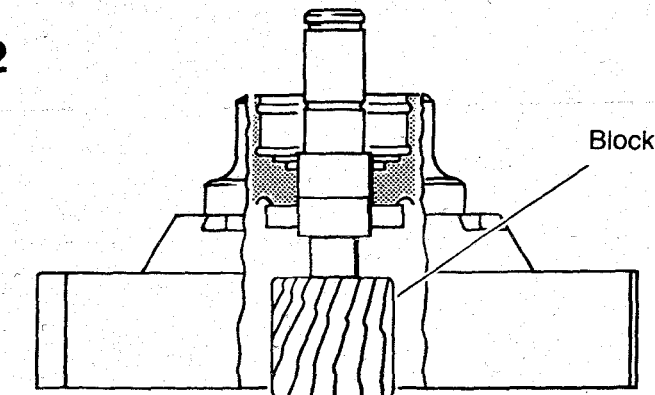

Fig. 33

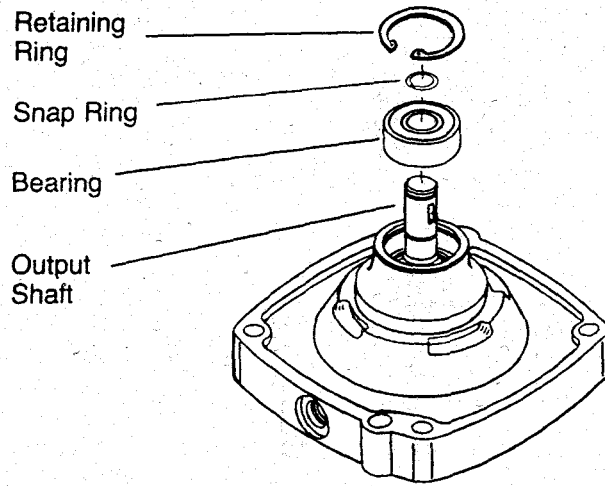

Fig. 34

**54** Install output shaft bearing by positioning bearing over output shaft and pressing on outer race of ball bearing to the bottom position in body.

**55** Install small snap ring on output shaft against inner bearing race.

**56** Install the large retaining ring used to retain ball bearing in body.

**Note:** The output shaft must rotate freely by hand. If it doesn't, recheck bearing installation.

**Motor Rotor—Installation**

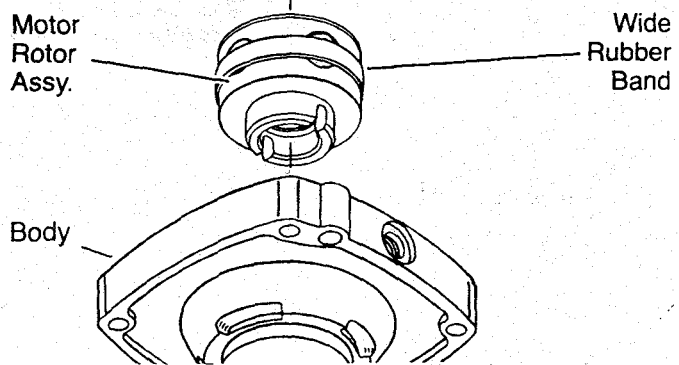

Fig. 35

**57** Align the slot in the motor rotor assembly with the cross pin on the output shaft and install the motor rotor in body.

**58** Remove the rubber band retaining the ball pistons in their respective bores (if used).

## Cover/Body—Reassembly

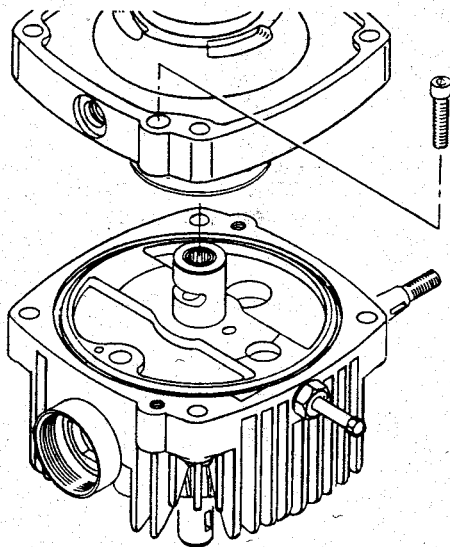

Fig. 36

**Important:** Be sure to realign previous scribed line for correct output rotation. If body assembly is installed 180° as previous assembled output rotation will be reversed.

59 Hold the motor rotor assembly in position and install body on pintle.

**Note:** Do not force motor rotor assembly on pintle as it is a slip fit and must turn freely by hand.

60 Install the (2)  $\frac{5}{16}$  x  $1\frac{1}{4}$  socket heat cap screws and torque to 15 foot pounds.

## Reservoir/Adapter—Reassembly

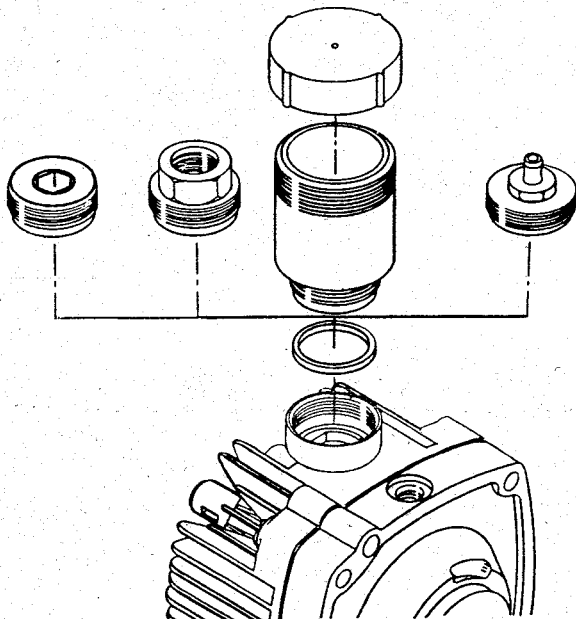

Fig. 37

61 Lightly grease sealing ring and install into recess in cover.

62 Install the adapter or reservoir in cover by rotating counterclockwise.

**Torque to Approximately 8–12 ft. lbs.**

**Important:** The adapters and reservoir are threaded left hand. To install, turn counterclockwise.

## Start-up Procedure

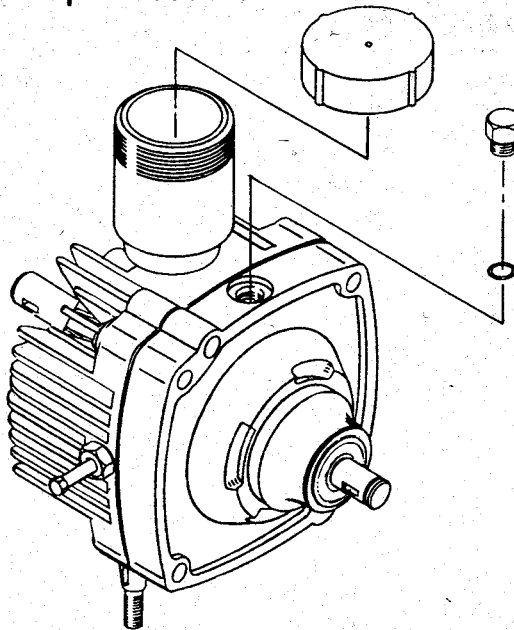

Fig. 38

63 Remove the  $\frac{3}{8}$  hex head plug to vent the transmission. See Page 16 for fluid recommendations.

### Attached Reservoir

Fill the transmission with the proper fluid through reservoir until fluid overflows from opening in body.

Rotate both the input and output shafts to purge any trapped air from transmission. Refill reservoir until fluid reappears and install hex head plug, **Torque to 2-5 Foot Pounds.**

Fill reservoir to oil level cold mark.

### Separate Reservoir

Fill the transmission with the proper fluid through customer supplied separate reservoir until fluid overflows from opening in body.

Rotate both the input and output shafts to purge any trapped air from transmission. Refill reservoir until fluid reappears and install hex head plug. **Torque to 2-5 Foot Pounds.**

Fill reservoir to proper fluid level shown.

## Trouble Shooting Instructions

This fault-logic troubleshooting section is designed as a diagnostic aid in locating transmission problems by the user.

Match the transmission problem with the problem statements and follow the action steps shown in the diagrams. This will give the user expedient aids in correcting the problem and eliminating unnecessary machine down time.

# System Jerky When Starting

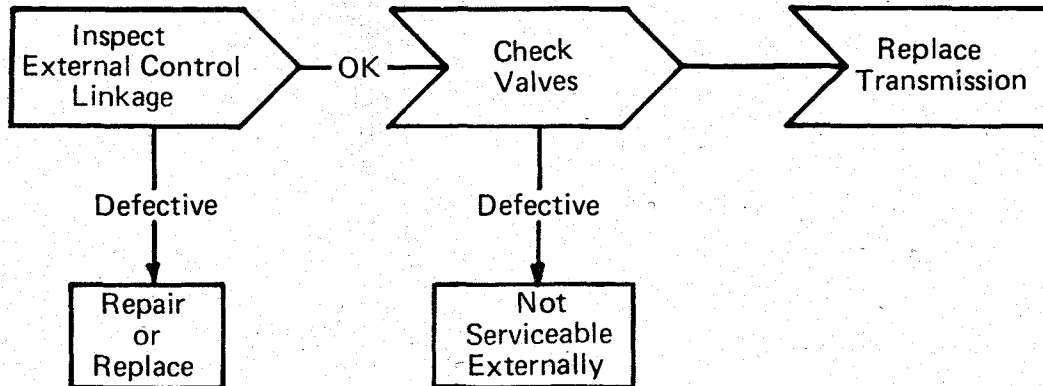

# System Operates in One Direction Only

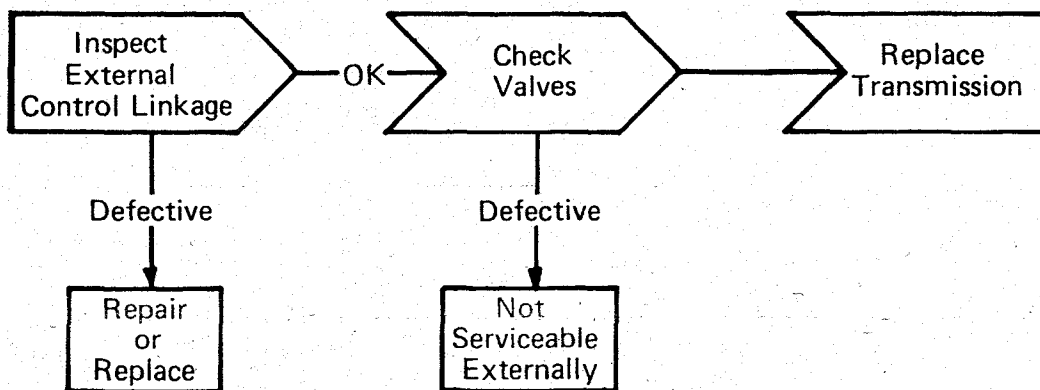

# System Operating Hot

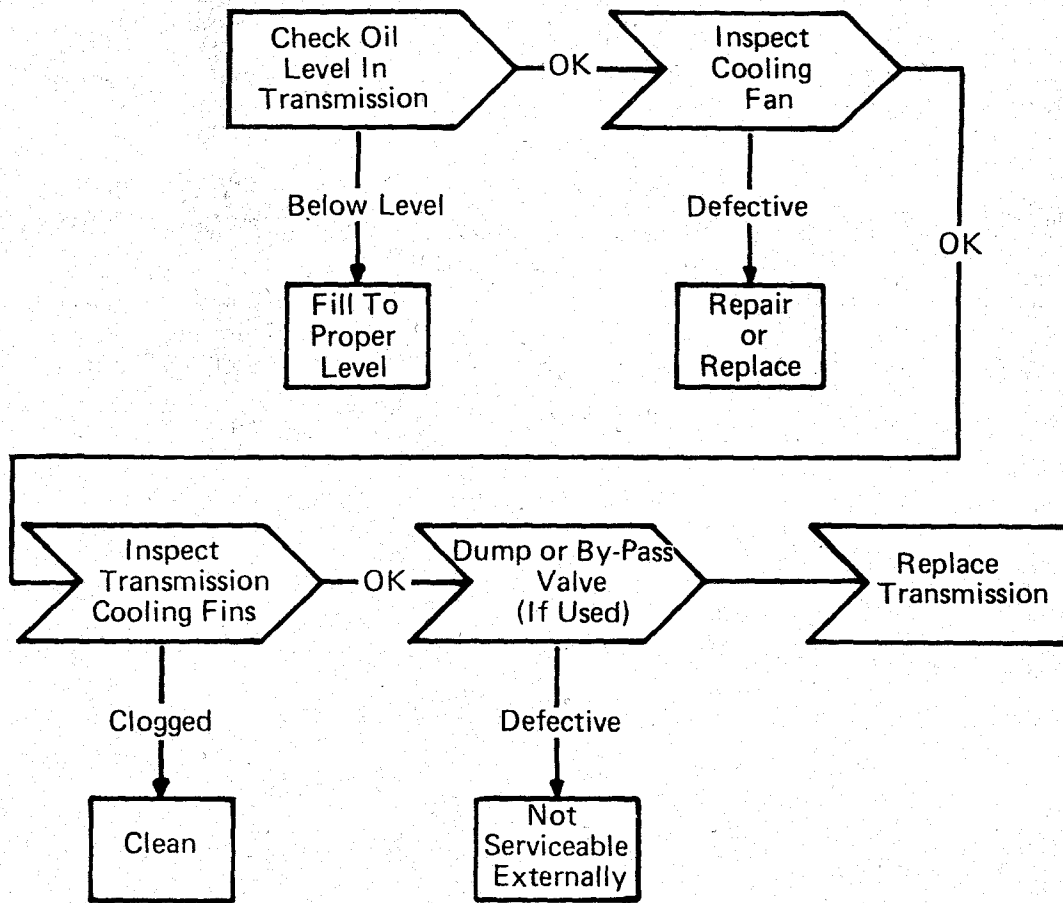

# Loss of Power or System Will Not Operate in Either Direction

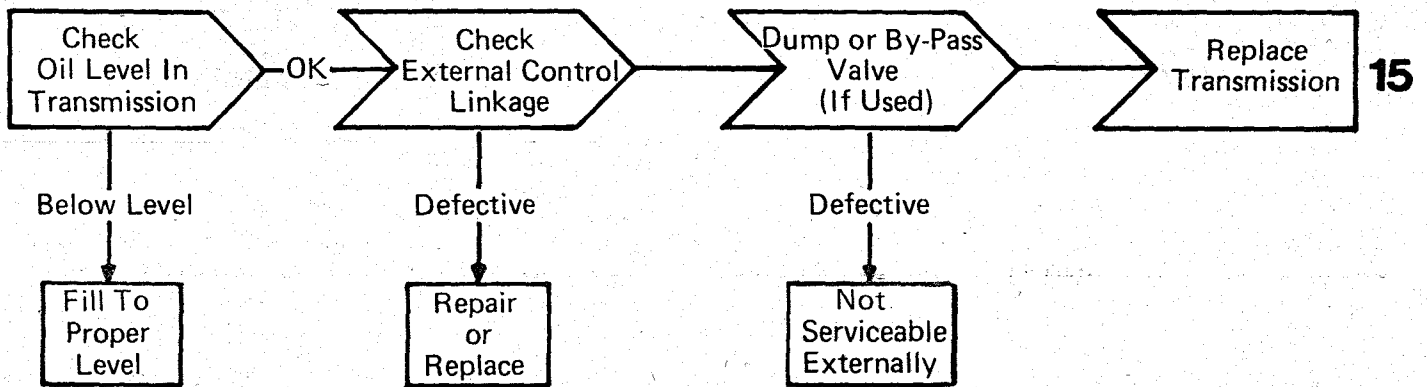

---

## Hydrostatic Fluid Recommendations

A reputable supplier can help you make the best selection of hydraulic fluid for use in Eaton hydrostatic products.

For satisfactory operation, the following recommendations apply:

1. The filter system used in the hydraulic circuit should be capable of cleaning and maintaining the hydraulic fluid to meet ISO Cleanliness Code 18/13 per SAE J1165. This code allows a maximum of 2500 particles per milliliter greater than 5  $\mu\text{m}$  and a maximum of 80 particles per milliliter greater than 15  $\mu\text{m}$ .
2. At normal operating temperatures, optimum viscosity ranges are from 80-180 SUS (16-39 cSt). Viscosity should never fall below 60 SUS (10 cSt) and, at the lowest expected start-up temperature, should not exceed 10,000 SUS (2158 cSt).
3. The fluid should be chemically stable, incorporating rust and oxidation inhibitors.

Specific types of fluid meeting these requirements are:

- Premium hydraulic oil\*
- Engine crankcase oil—SAE 10w, SAE 20w-20, SAE 30
- Automatic transmission oil
- Hydraulic transmission oil
- Synthetic fire resistant fluid—
  - Quintolubric 822-220, -300 or -450  
Quaker Chemical Co.  
Conshohocken, PA 19428
  - Cosmolubric HF-122, -130, -144 or -1530  
E.F. Houghton & Co.  
Valley Forge, PA
  - Milisafe Code 1274 (280 Series) 280-150, -300 or -500  
Future Trend Industries  
Cottage Grove, MN 55016

**Note:** If the natural color of the fluid has become black or milky, it is possible that an overheating or water contaminant problem exists.

For accurate level readings, take readings when the fluid is cold.

\*Supplied in Model 6 and 7 Transmissions, Model 750 and 770 Transaxles, and 780 Transaxles without charge pumps that are shipped from the Spencer factory. The viscosity of this factory fluid is equivalent to SAE 20w-20. The preferred fluids for all light duty transmissions, pumps, transaxles and motor axles are those having a viscosity equivalent to SAE 20w-20, SAE 30 or SAE 40.