





Engineered for Performance

For the past 55 years, Char-Lynn has been recognized as the industry leader in low-speed, high-torque (LSHT) hydraulic motor technology. Today, Eaton continues in this tradition of performance and innovation with the release of the HP30, the latest in the Char-Lynn motor line up.

Featuring exceptional starting torque efficiency and two-speed capability, the HP30 offers significant advantages over competitive radial piston and cam lobe designs. Also, by minimizing no load pressure drop to less than 23 bar [333 psi] at 133 lpm [35 gpm] in high speed mode – the best in the industry – the HP30 motor reduces parasitic heat build-up, thereby improving vehicle operating efficiency and reducing emissions.

Options available for the HP30 motor include standard and wheel versions, and an enhanced Eaton front-mounted, spring-applied, pressure-released (SAPR) hydraulic brake. Additional series circuit compatibility makes the HP30 a very versatile motor.

Table of Contents

Description	Page No.
Features, Benefits, and Applications	5
Specifications – Single-Speed	6
Performance Data	7
Dimensions – Standard Mount	10
Dimensions – Wheel Mount	11
Dimensions – Bearingless Mount	12
Installation Information - Bearingless Mount	13
Dimensions – HP30 Shaft Installation	14
Dimensions – Shaft Side Load Capacity	15
Product Numbers – Single-Speed and Two-Speed	16
Model Code	17
Description – Two-Speed	18
Typical Hydraulic Circuit – Two-Speed	19
Specifications – Two-Speed	20
Dimensions – Two-Speed Standard Mount	21
Dimensions – Two-Speed Wheel Mount	23
Dimensions – Two-Speed Bearingless	25
Typical Hydraulic Circuit – Closed Loop & Open Loop	27
Description – Brake Motor	30
Dimensions – Brake Motor Single-Speed	31
Dimensions – Brake Motor Two-Speed	32
Dimensions – Brake Side Shaft Load Capacity	33

More Torque, Less Heat



High Speed No Load Pressure Drop

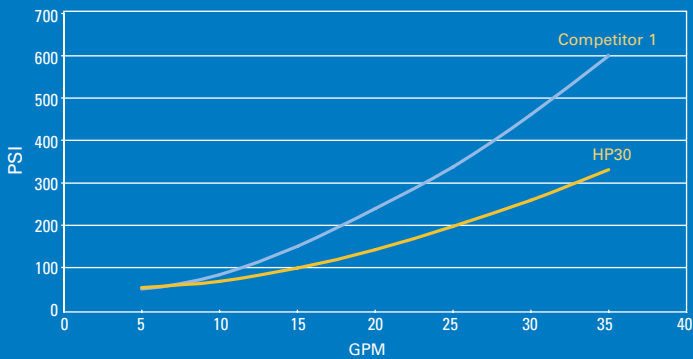

Mechanical Starting Efficiency
5000 psid, 0.1 rpm, 220°F Temp

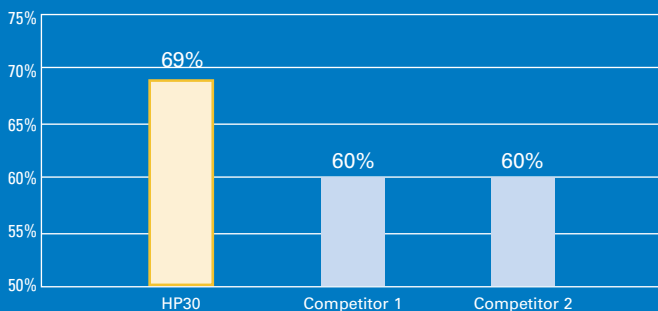

Many factors can dramatically affect the cost, and performance, of a hydraulic system. Heat generation and starting torque efficiency are two of the most significant. Eaton Char-Lynn HP30 motors provide industry leading performance in both areas, making them an ideal choice for both mobile and industrial hydraulic applications.

Heat Generation and System Cost

When a motor generates excess heat, this heat must be removed from the hydraulic system. Typically, this is done using oil coolers. The larger the cooler, the more expensive the system. The HP30 provides industry leading heat generation performance, minimizing system cooling costs and space requirements. This is achieved through a unique, patented valving design, which minimizes No Load Pressure Drop in both single and two-speed operating modes.

Starting Torque Efficiency and System Performance

High starting torque efficiency means that the HP30 motor provides maximum power to the output shaft at start-up and lower pressure and flow requirements to initiate rotation. In both mobile and stationary machines, the HP30 motor provides the starting torque needed for the most demanding applications.

Features, Benefits, and Applications



Features

Char-Lynn hydraulic motors provide design flexibility. All motors are available with various configurations consisting of:

- Displacement (Geroler size)
- Output shaft
- Port configuration
- Mounting flange

Benefits

- Lowest pressure drop motor in the industry
- The most experienced manufacturer of LSHT hydraulic motors
- High starting torque
- 2 speed capable
- Series circuit capable

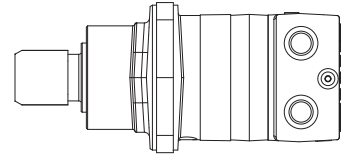
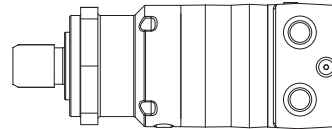

Standard Motor

The standard motor mounting flange is located as close to the output shaft as possible. This type of mounting supports the motor close to the shaft load. This mounting flange is also compatible with many standard gear boxes.

Wheel Motor

The wheel motor mounting flange is located near the center of the motor which permits part or all of the motor to be located inside the wheel or roller hub. In traction drive applications, loads can be positioned over the motor bearings for optimal bearing life. This wheel motor mounting flange provides design flexibility in many applications.

Applications for Eaton HP30 Motors

- Harvesters
- Augers
- Forestry Equipment
- Grinders and Mixers
- Horizontal/Vertical Drilling
- Material Handling
- Metal Forming
- Sprayers
- Skid Steer Loaders

Specifications

Single-Speed

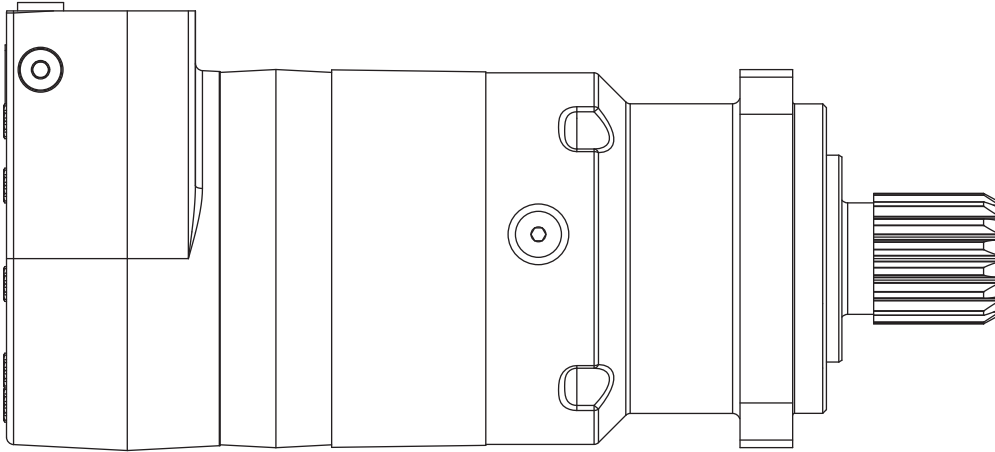

HP30 Series Motors, Single-Speed

Displ. cm ³ /r [in ³ /r]		344 [21.0]	400 [24.4]	434 [26.5]	480 [29.3]	677 [41.3]
Max. Speed [rpm] @ Flow	Continuous	495	426	392	355	252
	Intermittent	770	663	610	552	392
Flow l/min [gpm]	Continuous	170 [45]	170 [45]	170 [45]	170 [45]	170 [45]
	Intermittent	265 [70]	265 [70]	265 [70]	265 [70]	265 [70]
Torque Nm [lb-in]	Continuous	1,614 [14,288]	1,876 [16,601]	2,037 [18,030]	2,252 [19,935]	2,469 [21,856]
	Intermittent	1,794 [15,876]	2,084 [18,446]	2,263 [20,034]	2,503 [22,150]	2,893 [25,602]
Pressure Δ bar [Δ psi]	Continuous	310 [4,500]	310 [4,500]	310 [4,500]	310 [4,500]	241 [3,500]
	Intermittent	345 [5,000]	345 [5,000]	345 [5,000]	345 [5,000]	283 [4,100]
	Peak	379 [5,500]	379 [5,500]	379 [5,500]	379 [5,500]	310 [4,500]
Weight kg [lb]	Standard Mount	369 [81.4]	376 [82.8]	380 [83.7]	384 [84.7]	404 [89.0]
	Wheel Mount	397 [87.6]	404 [89.0]	407 [89.8]	412 [90.9]	432 [95.1]

Note: To assure best motor life, run motor for approximately one hour at 30% of rated pressure before application to full load. Be sure motor is filled with fluid prior to any load applications.

Maximum Inlet Pressure:

405 bar [5850 psi]

Do not exceed Δ pressure rating (see chart above).

Maximum Return Pressure:

405 bar [5850 psi] with case drain installed.

Do not exceed Δ pressure rating (see chart above).

Maximum Case Pressure:

20 bar [300 psi]

Δ bar [Δ psi]:

The true pressure difference between inlet port and outlet port.

Continuous Rating:

Motor may be run continuously at these ratings.

Intermittent Operation:

10% of every minute.

Peak Operation:

1% of every minute.

Recommended Fluids:

Premium quality, anti-wear type hydraulic oil with a viscosity of not less than 13 cSt [70 SUS] at operating temperature.

Recommended Maximum System Operating Temp.:

82°C [180°F]



Recommended Filtration:

Per ISO Cleanliness Code, 4406: 20/18/13.

Performance Data

Motors run with high efficiency in all areas designated with a number for torque and speed. For best motor life select a motor to run with a torque and speed range shown in the light shaded area.

Performance data is typical at 25.5 cSt [120 SUS]. Actual data may vary slightly from unit to unit in production.

-  Continuous
-  Intermittent
-  Peak

344 cm³/r [21 in³/r]
 Δ Pressure bar [psi]

	[500]	[1000]	[1500]	[2000]	[2500]	[3000]	[3500]	[4000]	[4500]	[5000]	[5500]
	34	69	103	138	172	207	241	276	310	345	379
(5)	[1472]	[3021]	[4579]	[5078]	[7624]	[9108]	[10720]	[12211]	[13768]	[15245]	[16676]
	166	341	517	574	861	1029	1217	1380	1556	1722	1884
19	50	48	46	44	43	40	39	38	38	36	33
(8)	[1491]	[3068]	[4604]	[6170]	[7762]	[9319]	[10876]	[12445]	[13984]	[15485]	[16891]
	169	347	520	697	877	1053	1229	1406	1580	1750	1908
30	81	76	74	74	74	72	70	68	66	64	61
(12)	[1462]	[3067]	[4613]	[6217]	[7779]	[9346]	[10948]	[12477]	[14015]	[15547]	[16951]
	165	346	521	702	879	1056	1237	1410	1583	1757	1915
45	124	118	114	113	113	112	110	108	106	103	100
(16)	[1436]	[3037]	[4608]	[6178]	[7753]	[9340]	[10914]	[12490]	[14040]	[15429]	[16866]
	162	343	521	698	876	1055	1233	1411	1586	1743	1906
61	167	159	154	152	151	151	150	148	145	143	140
(20)	[1408]	[3004]	[4576]	[6156]	[7744]	[9313]	[10902]	[12452]	[13830]	[15317]	[16809]
	159	339	517	696	875	1052	1232	1407	1563	1731	1899
76	211	201	195	191	190	189	188	187	185	183	179
(24)	[1351]	[2969]	[4556]	[6125]	[7724]	[9301]	[10897]	[12470]	[13972]	[15407]	[16679]
	153	335	515	692	873	1051	1231	1409	1579	1741	1885
91	255	243	237	232	229	227	226	226	223	220	218
(28)	[1340]	[2930]	[4501]	[6087]	[7665]	[9255]	[10835]	[12392]	[13792]	[15233]	[16704]
	151	331	509	688	866	1046	1224	1400	1558	1721	1887
106	296	285	278	273	269	266	265	264	253	250	245
(32)	[1303]	[2856]	[4443]	[6011]	[7604]	[9196]	[10779]	[12331]	[13679]	[15084]	[16600]
	147	323	502	679	859	1039	1218	1393	1546	1704	1875
121	341	328	319	312	308	305	303	302	301	298	294
(36)	[1287]	[2794]	[4378]	[5958]	[7522]	[9110]	[10688]	[12252]	[13568]	[15007]	[16569]
	145	316	495	673	850	1029	1208	1384	1533	1696	1872
136	384	371	361	354	349	345	341	338	334	331	328
(40)	[1253]	[2698]	[4317]	[5879]	[7443]	[9019]	[10586]	[12107]	[13451]	[14944]	[16505]
	142	305	488	664	841	1019	1196	1368	1520	1688	1865
151	427	414	403	395	390	385	381	379	377	374	370
(45)	[1237]	[2674]	[4203]	[5785]	[7331]	[8891]	[10472]	[11919]	[13429]	[14905]	[16474]
	140	302	475	654	828	1005	1183	1347	1517	1684	1861
170	485	465	455	446	440	434	430	426	423	421	418

[5785] } Torque [lb-in]
 654 } Nm
 446 } Speed RPM



400 cm³/r [24.4 in³/r]
 Δ Pressure bar [psi]

	[500]	[1000]	[1500]	[2000]	[2500]	[3000]	[3500]	[4000]	[4500]	[5000]	[5500]
	34	69	103	138	172	207	241	276	310	345	379
(4)	[1696]	[3461]	[5232]	[7051]	[8788]	[10516]	[12132]	[13884]	[15098]	[16504]	[18112]
	192	391	597	797	993	1188	1371	1569	1706	1865	2046
15	35	33	32	29	27	24	22	19	18	17	16
(8)	[1734]	[3566]	[5378]	[7198]	[9016]	[10801]	[12635]	[14376]	[16092]	[17786]	[19750]
	196	402	608	813	1019	1220	1428	1624	1818	201	2231
30	73	70	67	66	63	61	58	55	52	48	46
(12)	[1709]	[3560]	[5382]	[7225]	[9032]	[10837]	[12652]	[14448]	[16178]	[17912]	[19752]
	193	4002	608	816	1020	1224	1429	1632	1828	2024	2232
45	111	107	102	99	97	96	93	90	88	84	83
(16)	[1667]	[3514]	[5354]	[7194]	[9012]	[10840]	[12644]	[14421]	[16192]	[17953]	[19755]
	188	397	605	813	1018	1225	1429	1629	1829	2028	2232
61	148	143	139	134	132	130	128	125	121	118	116
(20)	[1650]	[3462]	[5306]	[7147]	[8966]	[10766]	[12586]	[14373]	[16139]	[17861]	[19745]
	186	391	599	807	1013	1216	1422	1624	1824	20018	2231
76	184	179	174	169	166	164	161	159	156	152	150
(25)	[1650]	[3351]	[5239]	[7074]	[8916]	[10685]	[12471]	[14257]	[15974]	[17715]	[19648]
	186	379	592	799	1007	1207	1409	1611	18055	2002	2220
95	231	225	219	214	209	205	202	199	197	194	191
(30)	[1631]	[3280]	[5112]	[6957]	[8765]	[10578]	[12402]	[14140]	[15908]	[17622]	[19528]
	184	371	578	786	990	1195	1401	1598	1797	1991	2206
114	278	270	264	259	254	249	245	242	238	233	231
(35)	[1553]	[3154]	[4986]	[6858]	[8658]	[10439]	[12268]	[14032]	[15792]	[17454]	[19350]
	175	356	563	775	978	1179	1386	1585	1784	1972	2186
132	325	317	310	303	298	293	288	284	279	274	271
(40)	[1514]	[3081]	[4881]	[6733]	[8532]	[10342]	[12116]	[13934]	[15659]	[17415]	[19301]
	171	348	551	761	964	1168	1369	1574	1769	1968	2181
151	371	363	355	348	341	335	329	323	317	310	305
(55)	[1457]	[2990]	[4602]	[6223]	[7977]	[9820]	[11633]	[13501]	[15236]	[16758]	[18500]
	165	338	520	703	904	1110	1314	1525	1721	1893	2090
208	510	500	481	481	470	464	456	443	433	428	425

Performance Data

Motors run with high efficiency in all areas designated with a number for torque and speed. For best motor life select a motor to run with a torque and speed range shown in the light shaded area.

Performance data is typical at 25.5 cSt [120 SUS]. Actual data may vary slightly from unit to unit in production.

-  Continuous
-  Intermittent
-  Peak

434 cm³/r [26.5in³/r] Δ Pressure bar [psi]

	[500]	[1000]	[1500]	[2000]	[2500]	[3000]	[3500]	[4000]	[4500]	[5000]	[5500]
	34	69	103	138	172	207	241	276	310	345	379
[5]	[1859] 210	[3828] 433	[5846] 660	[7798] 881	[9707] 1097	[11679] 1320	[13580] 1534	[15532] 1755	[17715] 2002	[19497] 2203	[21425] 2421
19	40	38	37	35	33	32	30	28	29	26	27
[8]	[1917] 2174	[3890] 440	[5878] 664	[7878] 890	[9867] 1115	[11834] 1337	[13790] 1558	[15797] 1784	[17767] 2007	[19788] 2236	[21610] 2442
30	66	64	62	60	58	56	54	52	51	49	47
[12]	[1883] 213	[3885] 439	[5878] 664	[7881] 890	[9858] 1114	[11839] 1338	[13859] 1566	[15853] 1791	[17818] 2013	[19785] 2235	[21706] 2452
45	100	97	94	92	89	87	84	82	80	78	76
[16]	[1838] 208	[3852] 435	[5847] 661	[7872] 889	[9853] 1113	[11838] 1338	[13862] 1566	[15893] 1796	[17850] 2017	[19839] 2241	[21761] 2459
61	135	130	127	125	122	119	116	113	111	109	106
[20]	[1794] 203	[3819] 431	[5824] 658	[7845] 886	[9843] 1112	[11848] 1339	[13869] 1567	[15884] 1798	[17843] 2016	[19799] 2237	[21725] 2455
76	169	164	160	157	154	151	148	144	141	139	138
[24]	[1753] 198	[3779] 427	[5791] 654	[7785] 880	[9763] 1103	[11791] 1332	[13846] 1564	[15825] 1788	[17817] 2013	[19801] 2237	[21734] 2456
91	203	197	193	189	186	183	180	177	174	171	169
[28]	[1688] 197	[3715] 420	[5742] 649	[7733] 874	[9738] 1100	[11768] 1330	[13789] 1558	[15806] 1786	[17794] 2010	[19751] 2232	[21696] 2451
106	238	231	226	222	218	215	212	209	206	203	200
[32]	[1588] 179	[3653] 413	[5657] 639	[7678] 867	[9657] 1091	[11682] 1320	[13713] 1549	[15711] 1775	[17695] 1999	[19727] 2229	[21634] 2444
121	273	264	258	254	250	246	243	240	237	235	232
[36]	[1549] 175	[3581] 405	[5591] 632	[7600] 859	[9607] 1085	[11613] 1312	[13655] 1543	[15643] 1767	[17650] 1994	[19613] 2216	[21580] 2438
136	307	298	292	287	282	279	275	271	267	264	261
[40]	[1559] 176	[3492] 395	[5489] 620	[7487] 846	[9504] 1074	[11523] 1302	[13515] 1527	[15588] 1761	[17555] 1983	[19507] 2204	[21518] 2431
151	341	333	325	319	314	310	306	302	299	295	292
[45]	[1539] 174	[3367] 380	[5382] 608	[7376] 833	[9371] 1059	[11378] 1286	[13423] 1517	[15413] 1741	[17452] 1972	[19379] 2189	[21348] 2412
170	388	376	367	361	356	350	346	341	337	331	325

[7376]
833
361 } Torque [lb-in]
Nm
Speed RPM



480 cm³/r [29.3 in³/r] Δ Pressure bar [psi]

	[500]	[1000]	[1500]	[2000]	[2500]	[3000]	[3500]	[4000]	[4500]	[5000]	[5500]
	34	69	103	138	172	207	241	276	310	345	379
[5]	[2030] 229	[4156] 470	[6239] 705	[8401] 949	[10381] 1173	[12499] 1412	[14668] 1657	[16741] 1892	[19004] 2147	[21234] 2399	[23044] 2604
19	36	34	32	31	30	29	28	27	26	26	25
[8]	[2059] 233	[4245] 48	[6393] 722	[8526] 863	[10726] 1212	[12911] 1459	[15052] 1701	[17096] 1932	[19250] 2175	[21386] 2416	[23509] 2656
30	59	56	54	53	52	51	50	49	47	45	44
[12]	[2043] 231	[4261] 481	[6424] 726	[8633] 975	[10768] 1217	[12918] 1460	[15167] 1714	[17274] 1952	[19448] 2197	[21527] 2432	[23674] 2675
45	90	86	84	83	80	79	77	73	75	73	75
[16]	[2014] 228	[4232] 478	[6417] 725	[8604] 972	[10800] 1220	[12956] 1464	[15181] 1715	[17330] 1958	[19482] 2201	[21545] 2434	[23605] 2667
61	121	116	113	111	109	108	106	104	103	102	101
[20]	[1971] 223	[4184] 473	[6377] 720	[8586] 970	[10764] 1216	[12916] 1459	[15137] 1710	[17295] 1954	[19378] 2189	[21434] 2422	[23390] 2643
76	152	146	142	139	137	135	133	132	131	130	128
[24]	[1918] 217	[4137] 467	[6325] 715	[8538] 965	[10715] 1210	[12889] 1456	[15073] 1703	[17201] 1944	[19396] 2191	[21426] 2421	[23357] 2639
91	183	176	172	169	166	164	163	161	159	159	158
[28]	[1844] 208	[4088] 462	[6270] 708	[8474] 957	[10648] 1203	[12859] 1453	[14966] 1691	[17131] 1936	[19218] 2171	[21166] 2391	[23211] 2622
106	214	207	202	198	195	193	192	190	188	188	183
[32]	[1785] 202	[3990] 451	[6204] 701	[8397] 949	[10600] 1198	[12798] 1446	[15029] 1698	[17032] 1924	[19073] 2155	[21209] 2396	[2328] 2630
121	246	237	232	228	224	221	220	218	215	212	205
[36]	[1682] 190	[3906] 441	[6107] 690	[8318] 940	[10479] 1184	[12680] 1433	[14802] 1672	[16928] 1913	[19033] 2150	[21022] 2375	[23073] 2607
136	277	268	261	257	253	250	247	246	244	243	242
[40]	[1623] 183	[3812] 431	[6014] 680	[8227] 930	[10423] 1178	[12599] 1424	[14712] 1662	[16821] 1900	[18978] 2144	[20968] 2369	[23004] 2599
151	308	298	291	286	282	279	277	276	273	272	269
[45]	[1593] 180	[3733] 422	[5901] 667	[8107] 916	[10256] 1159	[12453] 1407	[14601] 1650	[16702] 1887	[18803] 2125	[20837] 2354	[23039] 2603
170	346	336	328	322	317	314	311	309	307	306	304

Performance Data

Motors run with high efficiency in all areas designated with a number for torque and speed. For best motor life select a motor to run with a torque and speed range shown in the light shaded area.

Performance data is typical at 25.5 cSt [120 SUS]. Actual data may vary slightly from unit to unit in production.

 Continuous
 Intermittent

677cm³/r [41.3 in³/r]
Δ Pressure bar [psi]

	[500]	[1000]	[1500]	[2000]	[2500]	[3000]	[3500]	[4000]	[4500]
	34	69	103	138	172	207	241	276	310
[5]	[2891] 327	[5874] 664	[8849] 1000	[11879] 1342	[14733] 1665	[18029] 2037	[21058] 2379	[24108] 2724	[26345] 2977
19	24	22	21	20	18	18	18	17	16
[8]	[2946] 333	[5976] 675	[9040] 1021	[12173] 1375	[15193] 1717	[18209] 2057	[21319] 2409	[24331] 2749	[27149] 3067
30	41	38	36	35	33	32	31	30	29
[12]	[2949] 333	[6045] 683	[9153] 1034	[12250] 1384	[15322] 1731	[18427] 2082	[21576] 2438	[24476] 2765	[27610] 3119
45	63	58	55	54	54	53	51	50	49
[16]	[2894] 327	[6012] 679	[9092] 1027	[12148] 1373	[15242] 1722	[18400] 2079	[21479] 2427	[24558] 2773	[27562] 3114
61	85	80	75	72	71	71	70	68	67
[20]	[2819] 318	[5936] 671	[9011] 1018	[12090] 1366	[15221] 1720	[18322] 2070	[21481] 2427	[24547] 2773	[27517] 3109
76	108	102	96	92	91	91	90	89	87
[24]	[2740] 310	[5846] 661	[8918] 1008	[11991] 1355	[15079] 1704	[18242] 2061	[21380] 2416	[24421] 2759	[27386] 3094
91	130	124	118	113	111	110	110	109	107
[28]	[2640] 298	[5757] 650	[8843] 999	[11896] 1344	[14926] 1686	[18030] 2037	[21241] 2400	[24273] 2742	[27183] 3071
106	153	146	139	133	131	128	128	127	126
[32]	[2511] 284	[5621] 635	[8715] 985	[11761] 1329	[14858] 1679	[18015] 2035	[21090] 2383	[24209] 2735	[27101] 3062
121	175	168	160	154	151	150	150	150	147
[36]	[2364] 267	[5508] 622	[8581] 969	[11666] 1318	[14749] 1666	[17898] 2022	[20993] 2372	[24048] 2717	[26990] 3050
136	197	190	181	175	172	170	170	170	169
[40]	[2257] 255	[5398] 610	[8498] 960	[11591] 1310	[14680] 1659	[17844] 2016	[20981] 2371	[24035] 2716	[26911] 3041
151	220	211	203	195	191	190	190	191	190
[45]	[2134] 241	[5193] 587	[8294] 967	[11413] 1290	[14489] 1637	[17596] 1988	[20716] 2341	[23818] 2691	[26687] 3015
170	247	239	230	223	218	214	212	212	212

[11413] } Torque [lb-in]
 1290 } Nm
 223 } Speed RPM

Dimensions

Standard Mount

Main Ports

1-1/16-12 UN-2B SAE O-ring Ports (2)

9/16-18 UNF-2B SAE O-ring Case Drain Port (1)

or

G1 (BSP) O-ring Ports (2)

G1/4 (BSP) O-ring Case Drain Port (1)

Standard Rotation Viewed from Shaft End

Port A Pressurized – CW

Port B Pressurized – CCW

Closed Loop Configuration

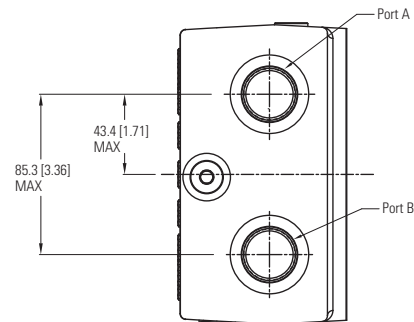

Open Loop Configuration

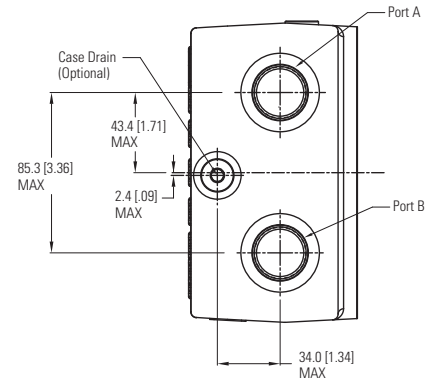

Closed Loop

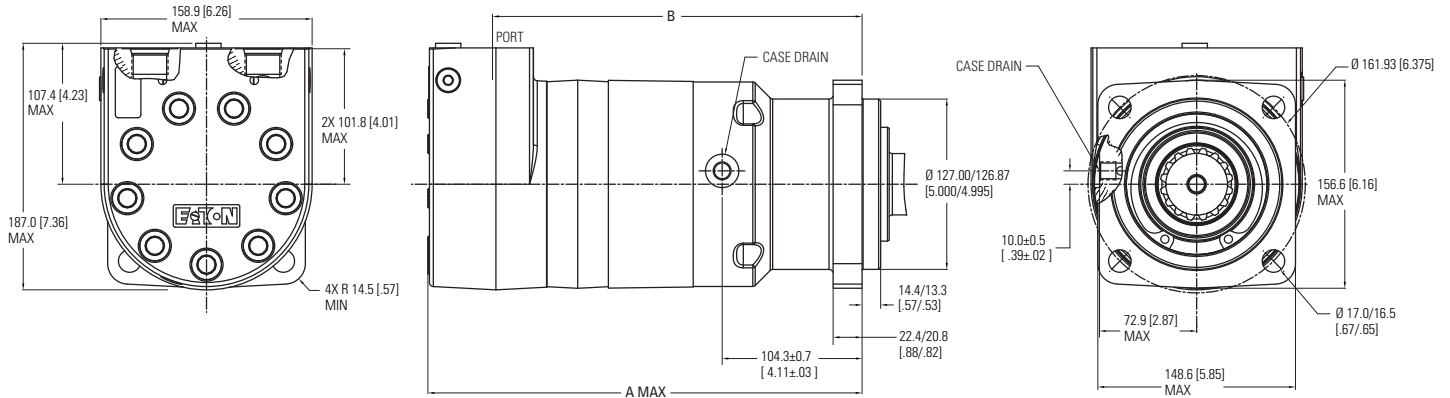

Open Loop

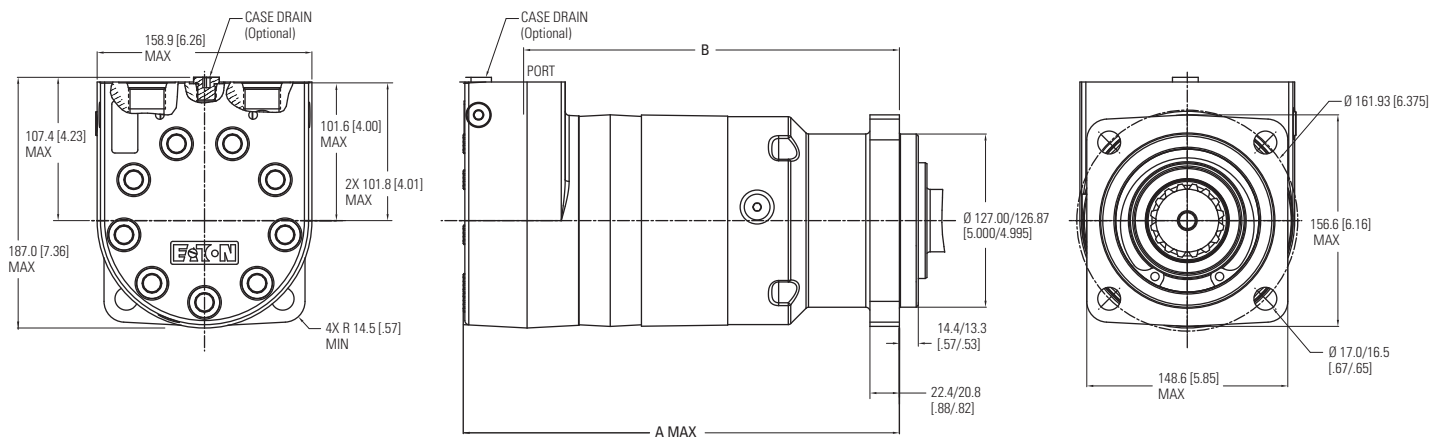

Motor Dimensions – Standard Mount

Displacement cm ³ /r [in ³ /r]	A Max		B	
	mm	[in]	mm	[in]
344 [21.0]	293.9	[11.57]	244.3	[9.62]
400 [24.4]	299.1	[11.78]	249.6	[9.83]
434 [26.5]	302.4	[11.91]	252.8	[9.95]
480 [29.3]	306.5	[12.07]	256.9	[10.12]
677 [41.3]	325.0	[12.80]	275.4	[10.84]

Note: Use of a Case Drain is optional in an open loop circuit if motor case pressure does not exceed 300 psi.

Dimensions

Wheel Mount

Main Ports

1-1/16-12 UN-2B SAE O-ring Ports (2)

9/16-18 UNF-2B SAE O-ring Case Drain Port (1)

or

G1 (BSP) O-ring Ports (2)

G1/4 (BSP) O-ring Case Drain Port (1)

Standard Rotation Viewed from Shaft End

Port A Pressurized – CW

Port B Pressurized – CCW

Closed Loop Configuration

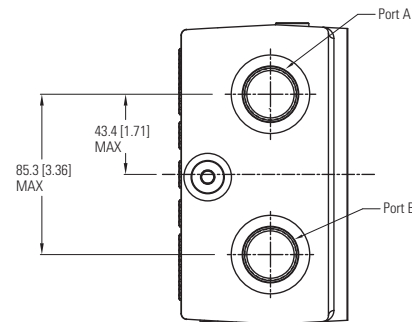

Open Loop Configuration

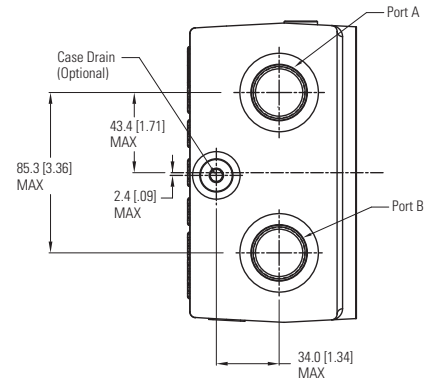

Closed Loop

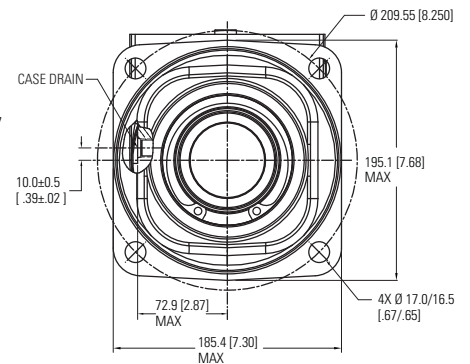
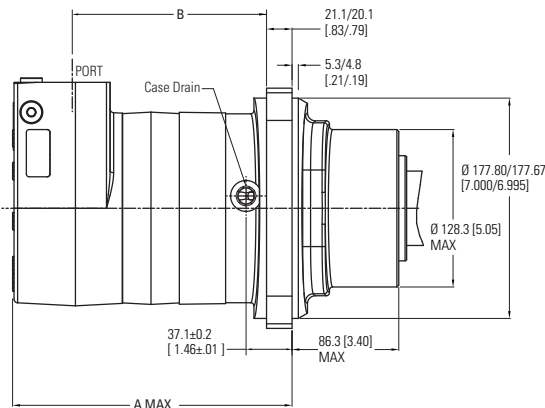
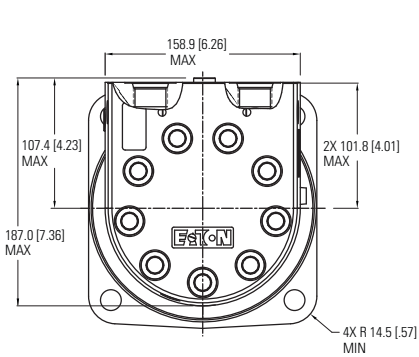

Open Loop

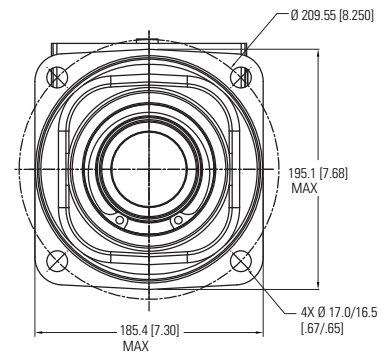
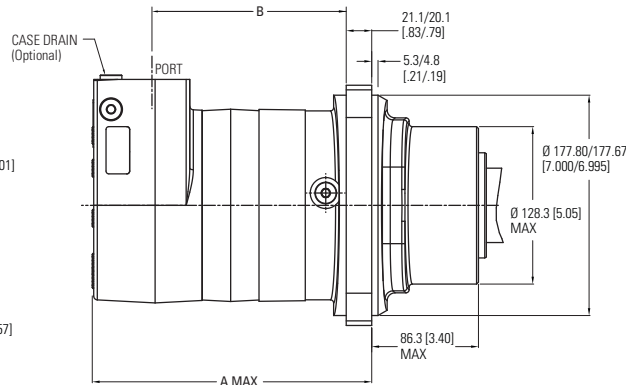
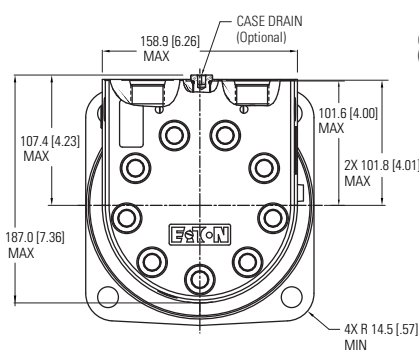

Motor Dimensions – Wheel Mount

Displacement cm ³ /r [in ³ /r]	A Max		B	
	mm	[in]	mm	[in]
344 [21.0]	221.3	[8.71]	172.0	[6.77]
400 [24.4]	226.6	[8.92]	177.3	[6.98]
434 [26.5]	229.9	[9.05]	180.5	[7.11]
480 [29.3]	234.0	[9.21]	184.7	[7.27]
677 [41.3]	252.5	[9.94]	203.2	[8.00]

Note: Use of a Case Drain is optional in an open loop circuit if motor case pressure does not exceed 300 psi.

Dimensions

Bearingless Mount

For HP30 bearingless motor application information, contact your Eaton representative (mating coupling blanks available from Eaton Hydraulics).

Main Ports

- 1-1/16-12 UN-2B SAE O-ring Ports (2)
- 9/16-18 UNF-2B SAE O-ring Case Drain Port (1)
- or
- G1 (BSP) O-ring Ports (2)
- G1/4 (BSP) O-ring Case Drain Port (1)

Standard Rotation Viewed from Drive End

- Port A Pressurized — CW
- Port B Pressurized — CCW

Closed Loop Configuration

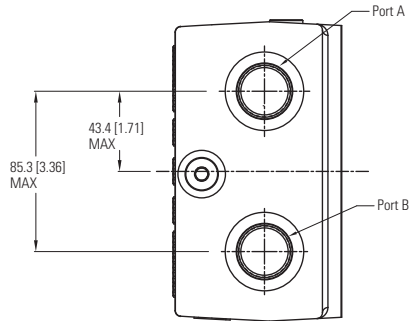

Open Loop Configuration

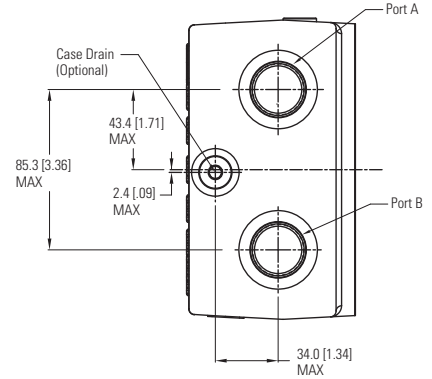

Closed Loop

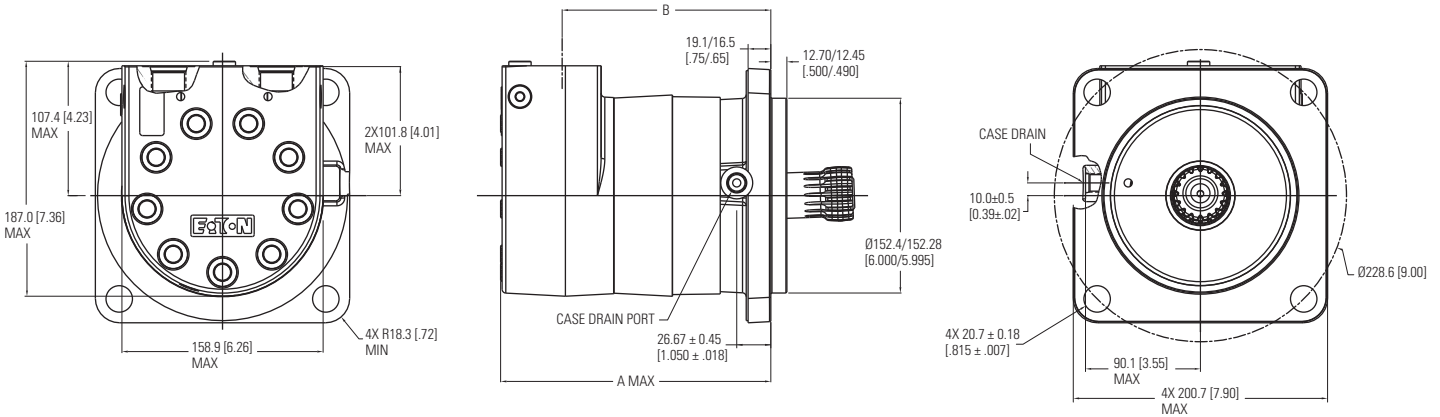

Open Loop

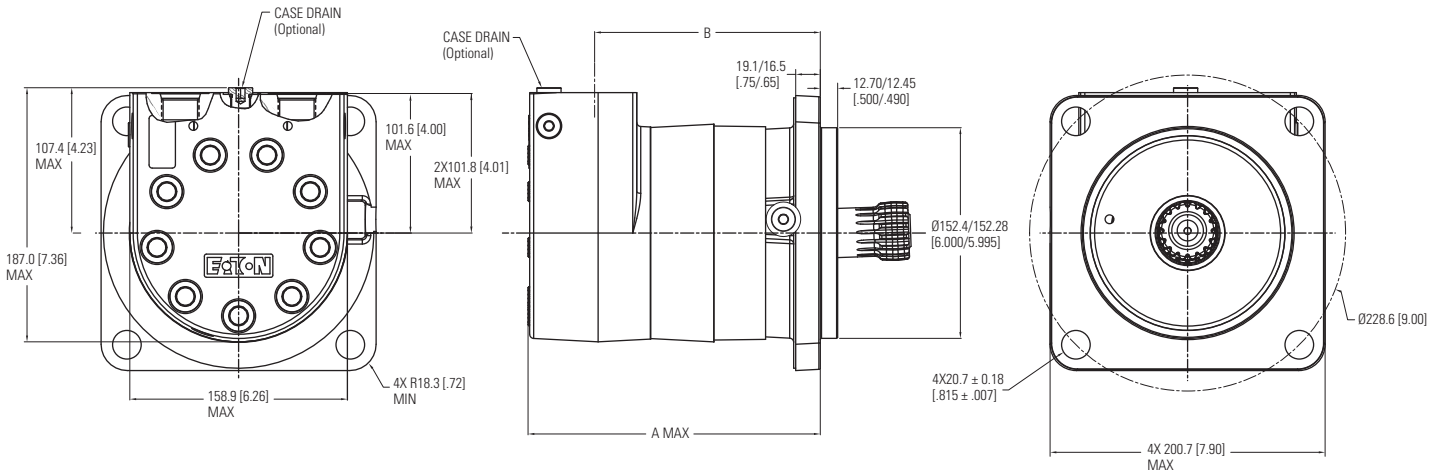

Motor Dimensions – Bearingless

Displacement cm ³ /r [in ³ /r]	A Max mm [in]	B mm [in]
344 [21.0]	207.1 [8.15]	158.0 [6.22]
400 [24.4]	212.3 [8.36]	163.3 [6.43]
434 [26.5]	215.6 [8.49]	166.5 [6.56]
480 [29.3]	219.7 [8.65]	170.6 [6.72]
677 [41.3]	238.2 [9.38]	189.2 [7.45]

Note: Use of a Case Drain is optional in an open loop circuit if motor case pressure does not exceed 300 psi.

Install Instructions

Bearingless Mount

- 1 Internal spline in mating part to be per spline data. Specification material to be ASTM A304, 8620H carburize to a hardness of 60-64 HRc with case depth (to 50HRc) of 0,076 -1,27 [.030 -.050]. Dimensions apply after heat treat.
- ② Mating part to have critical dimensions as shown. Oil holes must be provided and open for proper oil circulation.
- ③ Seal to be furnished with motor for proper oil circulation thru splines.

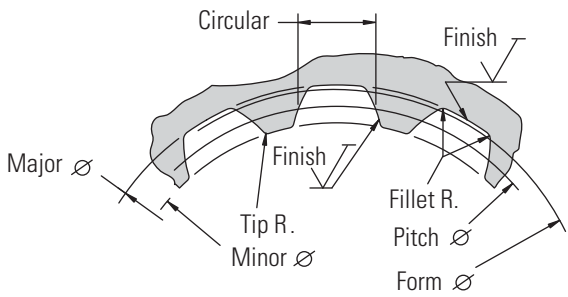
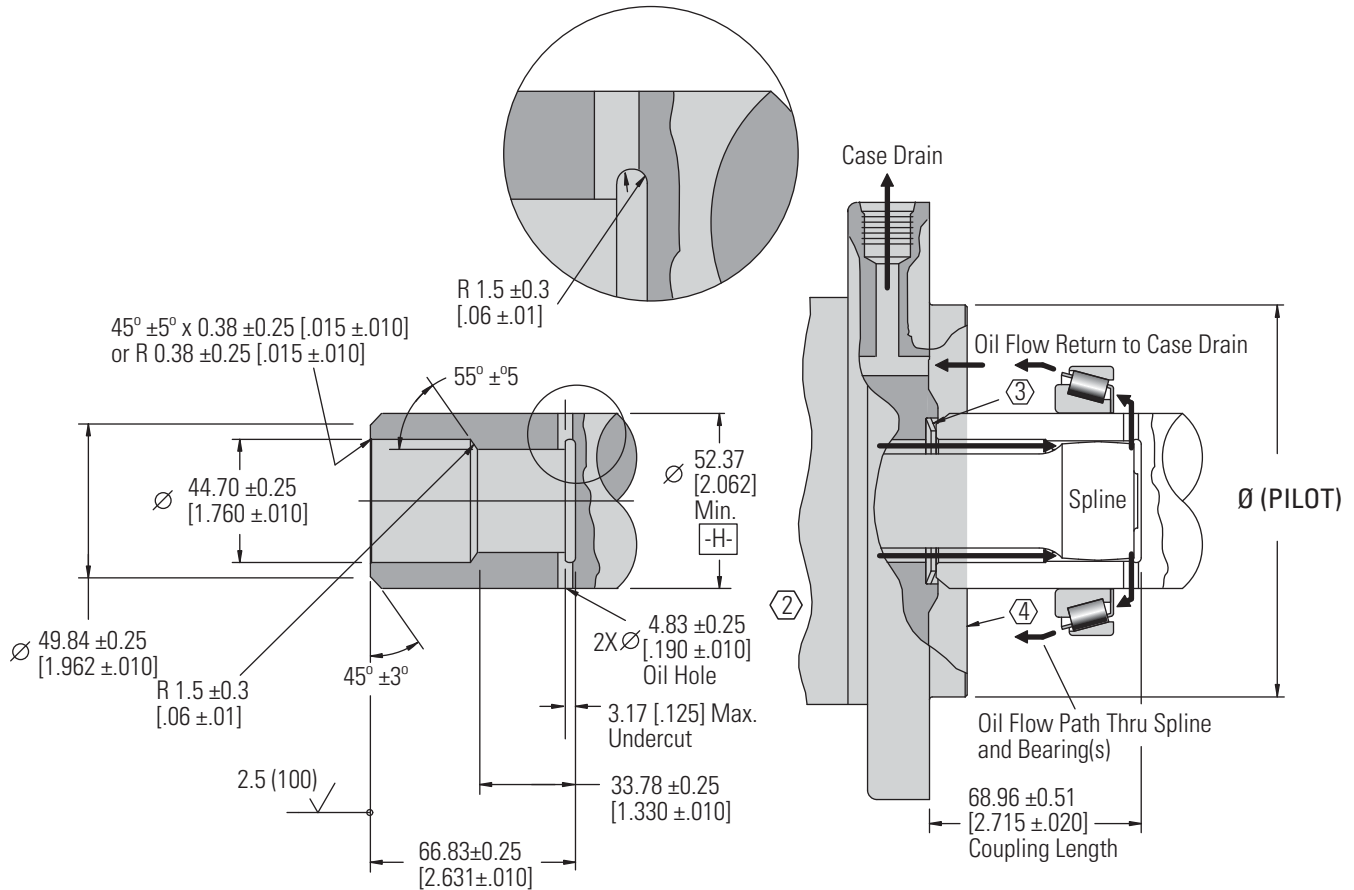

Spline Pitch	10/20
Pressure Angle	30°
Number of teeth	16
Class of Fit	Ref. 5
Type of Fit	SIDE
Pitch Diameter	Ref. 40.640000 [1.6000000] H 0,20 [.008] H
Base Diameter	Ref. 35.195272 [1.3856406]
Major Diameter	43.56 [1.715] MAX 43.18 [1.700] MIN
Minor Diameter	36.83-37.08 [1.450-1.460]
Form Diameter, Min.	42.47 [1.672]
Fillet Radius	0.64-0.76 [.025-.030]
Tip Radius	0.25-0.51 [.010-.020]
Finish	1.6 [63]
Involute Profile Variation	+0.000 -0.025 [+0.000 -.0010]
Total Index Variation	0.040 [0.016]
Lead Variation	0.013 [0.0005]
Circular Space Width:	
Maximum Actual	4.105 [1.616]
Minimum Effective	3.995 [1.573]
Maximum Effective	Ref. 4.081 [1.582]
Minimum Actual	Ref. 4.081 [1.582]
Dimension Between Two Pins	Ref. 34.272-34.450 [1.3493-1.3563]
Pin Diameter	4.389 [1.728]

Note: Close loop shown - flow path reverses for open loop configuration.

Dimensions

HP30 Shaft Installation

Code 01

2 1/8 Inch 16 Tooth Splined

2712 [24000] Max. Torque Nm [lb-in]

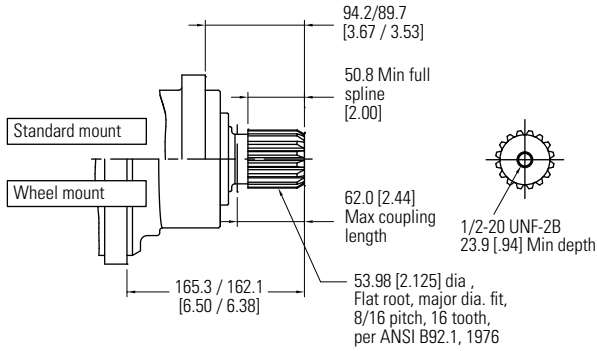

Code 02

2 1/4 Inch Straight

2712 [24000] Max. Torque Nm [lb-in]

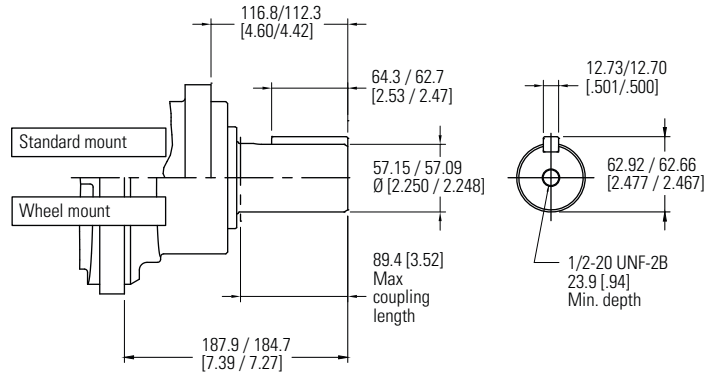

Code 03

2 1/4 Inch Tapered

2712 [24000] Max. Torque Nm [lb-in]

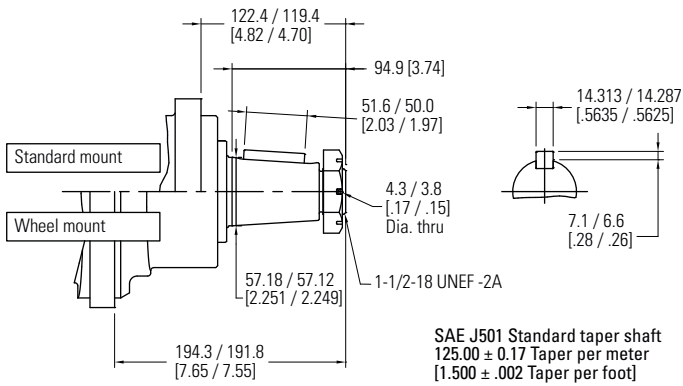

Tapered Shaft Hub Data

Recommended torque:
(1150 Nm [850 lb-ft] dry)
(880 Nm [650 lb-ft] lub)
Plus torque required to
align the slotted nut with
the shaft crosshole.

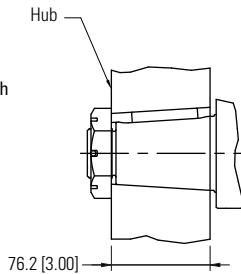

Slotted Hexagon Nut

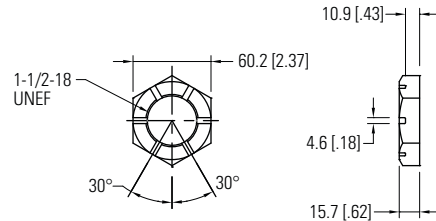

Dimensions

Shaft Side Load Capacity

These curves indicate the radial load capacity on the motor shaft at various locations with an external thrust load of 454 kg [1,000 lb].

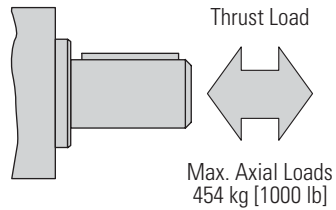

Note: Case pressure will increase the allowable inward thrust load and decrease the allowable outward thrust load. Case pressure will push outward on the shaft at 199 kg/7 Bar [438 lb/100 psi].

Each curve is based on B 10 bearing life [2000 hours of 12,000,000 shaft revolutions at 100 rpm] at rated output torque. To determine radial load at speeds other than 100 rpm, multiply the load values given on the bearing curve by the factors in the chart below.

rpm	Multiplication Factor
50	1.23
100	1.00
200	0.81
300	0.72
400	0.66
500	0.62
600	0.58
700	0.56
800	0.54

For 3,000,000 shaft revolutions or 500 hours – Increase these shaft loads 52%.

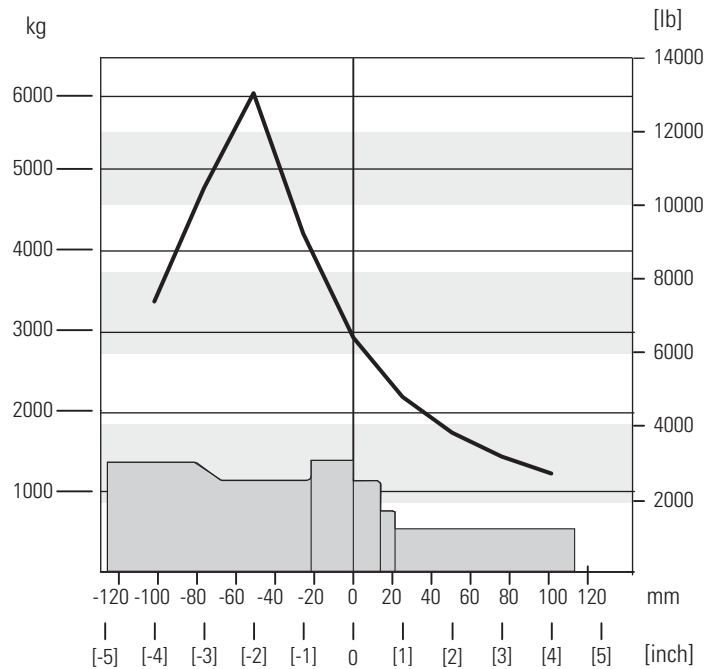

HP 30 Standard Mount

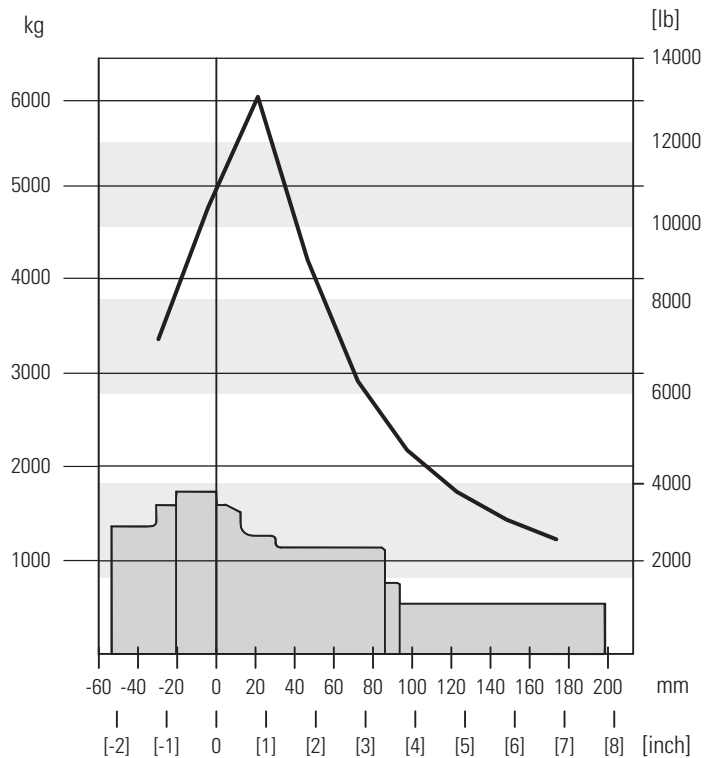

HP 30 Wheel Mount

Product Numbers

Single-Speed

Note: For HP30 Series Motors with a configuration not shown in the chart below: Use model code number system on the next page to specify product in detail.

Use digit prefix — 187- or 188-, plus four digit number from charts for complete product number— Example 187-0029.

Orders will not be accepted without three digit prefix.

Mounting	Shaft	Port Size	Displ. cm ³ /r [in ³ /r] / Product Number				
			344 [21.0]	400 [24.4]	434 [26.5]	480 [29.3]	677 [41.3]
Standard Motor	2 1/8 Inch 16 T Splined	1-1/16-12 UN O-ring (2) 9/16-18 UNF O-ring (1)	187-0029	-0030	-0031	-0032	-0033
	2 1/4 Inch Straight	1-1/16-12 UN O-ring (2) 9/16-18 UNF O-ring (1)	187-0034	-0035	-0036	-0037	-0038
	2 1/4 Inch Tapered	1-1/16-12 UN O-ring (2) 9/16-18 UNF O-ring (1)	187-0039	-0040	-0041	-0042	-0043
Wheel Motor	2 1/8 Inch 16 T Splined	1-1/16-12 UN O-ring (2) 9/16-18 UNF O-ring (1)	188-0008	-0009	-0010	-0011	-0012
	2 1/4 Inch Straight	1-1/16-12 UN O-ring (2) 9/16-18 UNF O-ring (1)	188-0013	-0014	-0015	-0016	-0017
	2 1/4 Inch Tapered	1-1/16-12 UN O-ring (2) 9/16-18 UNF O-ring (1)	188-0018	-0019	-0020	-0021	-0022

188-0019

Two-Speed

Note: For HP30 Series Motors with a configuration not shown in the chart below: Use model code number system on the next page to specify product in detail.

Use digit prefix — 190- or 191- plus four digit number from charts for complete product number— Example 190-0097.

Orders will not be accepted without three digit prefix.

Mounting	Shaft	Port Size	Displ. cm ³ /r [in ³ /r] / Product Number				
			344 [21.0]	400 [24.4]	434 [26.5]	480 [29.3]	677 [41.3]
Standard Motor	2 1/8 Inch 16 T Splined	1-1/16-12 UN O-ring (2) 9/16-18 UNF O-ring (1)	190-0097	-0098	-0099	-00100	-0101
	2 1/4 Inch Straight	1-1/16-12 UN O-ring (2) 9/16-18 UNF O-ring (1)	190-0102	-0103	-00104	-00105	-0106
	2 1/4 Inch Tapered	1-1/16-12 UN O-ring (2) 9/16-18 UNF O-ring (1)	190-0107	-0108	-00109	-00110	-0111
Wheel Motor	2 1/8 Inch 16 T Splined	1-1/16-12 UN O-ring (2) 9/16-18 UNF O-ring (1)	191-0036	-0037	-0038	-0039	-0040
	2 1/4 Inch Straight	1-1/16-12 UN O-ring (2) 9/16-18 UNF O-ring (1)	191-0041	-0042	-0043	-0044	-0045
	2 1/4 Inch Tapered	1-1/16-12 UN O-ring (2) 9/16-18 UNF O-ring (1)	191-0046	-0047	-0048	-0049	-0050

Model Code

The following 30-digit coding system has been developed to identify all of the configuration options for the HP30 Series motor. Use this model code to specify a motor with the desired features. All 30-digits of the code must be present when ordering. You may want to photocopy the matrix below to ensure that each number is entered in the correct box.

M	HP3	1A	21	AA	00	AA	01	0	0	0	0	0	00	00	00	00	B
□	□	□	□	□	□	□	□	□	□	□	□	□	□	□	□	□	□
1	2,3,4	5, 6	7, 8	9, 10	11, 12	13, 14	15, 16	17	18	19	20	21	22, 23	24, 25	26, 27	28, 29	30

1 **Product**
M – Motor

2,3,4 **Product Series**
HP3 – HP30 Series

5,6 **Configuration**
1A – Single-speed
1B – Single-speed w/spring applied hydraulic release wet brake
2A – Two-speed
2B – Two-speed w/spring applied hydraulic release wet brake

7,8 **Displacement**
21 – 343.8 cm³/r [20.98 in³/r]
24 – 400.0 cm³/r [24.40 in³/r]
26 – 434.2 cm³/r [26.50 in³/r]
29 – 479.5 cm³/r [29.26 in³/r]
41 – 677.3 cm³/r [41.33 in³/r]

9,10 **Mounting Type**
AA – Brake, 4 bolts 169.75 [6.683] pilot dia. With 4.3 [1.17] pilot length and m16 x 2-6h threaded holes on 224.00 [8.819] dia. Bolt circle
BA – Bearingless, 3 bolt: 127.0 [5.00] pilot dia. 16.76 [1.660] dia. Holes on 189.0 [7.44] dia. Bolt circle
BB – Bearingless, 4 bolt: 152.4[6.00] pilot dia. 20.70 [1.815] dia. Holes on 228.6 [9.00] dia. Bolt circle

SA – Standard, 4 bolt: 127.00 [5.000] pilot dia. 17.02 [1.670] dia. Holes on 161.92 [6.375] dia. Bolt circle
SB – Standard, 4 bolt: 127.00 [5.000] pilot dia. 17.70 [1.697] dia. Holes on 162.3 [6.390] dia. bolt circle
SD – Standard, 4 bolt: 160.00 [6.299] pilot dia. 18.0 [1.71] dia. Holes on 200.0 [7.87] dia. Bolt circle
SE – Standard, 4 bolt: 125.00 [4.921] pilot dia. 14.00 [1.551] dia. Holes on 160.00 [6.299] dia. Bolt circle
WA – Wheel, 4 bolt: 177.80 [7.000] pilot dia. 17.02 [1.670] dia. Holes on 209.55 [8.250] dia. Bolt circle

11,12 **Output Shaft**
00 – None (Bearingless)
01 – Splined, 16t 8/16 dp with ½-20 threaded hole
02 – Straight Keyed, 2¼" dia. with ½-20 threaded hole
03 – Tapered, 2¼" SAE J501 with 1½-18 thread and slotted nut
04 – Straight Keyed, 50mm dia. with M12 metric threaded hole
07 – Straight Keyed, 40mm dia. with M12 metric threaded hole
08 – Splined, 17t 12/24 dp with M12 Metric threaded hole
10 – Tapered, 60mm ISO R775 with M42 thread and slotted nut

13,14 **Port Type**
AA – #12 SAE O-ring ports
AE – G 1 BSP straight thread ports

15,16 **Case Flow Option**
01 – Shuttle Valve with .5625-18 UNF-2B SAE O-ring Case Drain Port in Mounting Flange. (Closed loop circuits)
04 – Check Valve With Orifice Plug, G 1/4 BSP Straight Thread Case Drain Port in Valve Housing. (Open loop circuits)
05 – Shuttle Valve with G 1/4 BSP Straight Thread Case Drain Port in Mounting Flange. (Closed loop circuits)
06 – Check Valve With Orifice Plug, .5625-18 UNF-2B SAE O-ring Case Drain Port in Valve Housing. (Open loop circuits)

17 **Low Pressure Relief**
0 – None
A – Set @ 4.5 bar (65 psi)
B – Set @ 11.0 bar (160 psi)
C – Set @ 15.2 bar (220 psi)
D – Set @ 20.7 bar (300 psi)

18 **Pressure/flow Option**
0 – None

19 **Geroler Option**
0 – None

20 **Seal Option**
0 – None

21 **Speed Sensor Option**
0 – None

22,23 **Special Features (Hardware)**
00 – None
05 – Balance Plate (Required for Two-Speed Models Only)

24,25 **Special Features (Assembly)**
00 – None
01 – Reverse rotation

26,27 **Paint Option**
00 – No paint
AA – Painted low gloss black
AD – Painted industrial yellow
AE – Painted charcoal gray

28,29 **Customer Identification**
00 – None

30 **Design Code**
B – Two

Note: 2 speed motors must have a balance plate (option 05) Special Features. Balance plate is not available on single-speed motors.

Description

Two-Speed

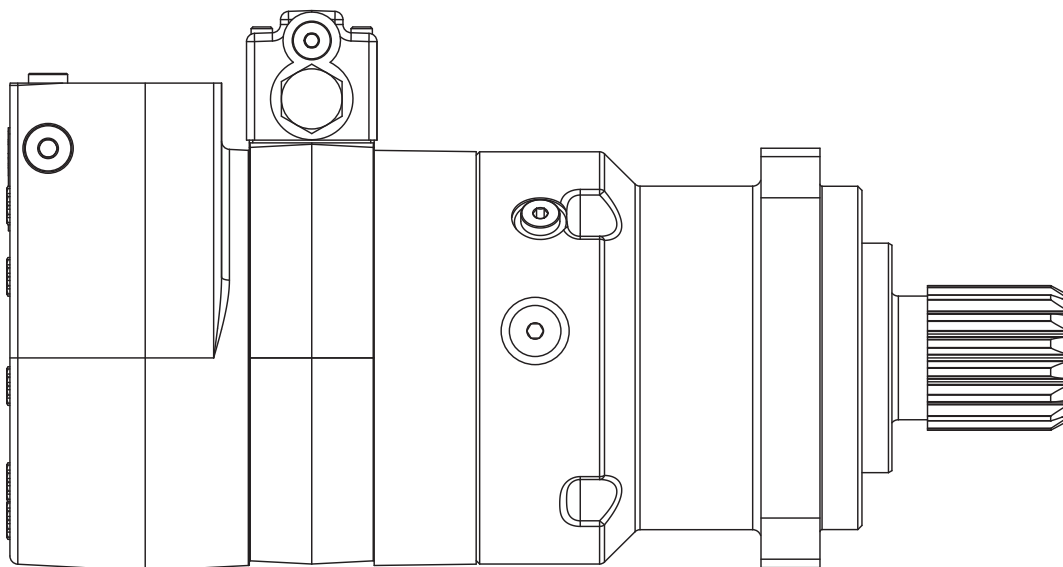

HP30 Series motors are available with an integral two-speed feature that allows the operator to shift the motor between low speed high torque (LSHT) mode and high speed low torque (HSLT) mode.

In the LSHT mode, output torque and rotation speed values are equal to those of the conventional HP30 motor. In the HSLT mode motor displacement is reduced by one third, resulting in a fifty percent increase in rotation speed and a torque output reduction of one third.

The HP30 two-speed motor is bidirectional. It will function with equal shaft output in either rotation direction (CW or CCW) in both LSHT or HSLT modes. Shift on the fly technology allows full-power operation throughout the full duration of the shift.

Changing between modes is accomplished by changing the displacement in a ratio of 1 to 1.5. An external two-position three-way control valve is required for shifting pressure to the pilot port between low pressure (LSHT mode) and pilot signal pressure (HSLT mode).

An integral selector valve shift the motor from LSHT mode to HSLT mode. Initially, low pressure is supplied to the pilot port. The selector valve is biased to LSHT mode by a return spring. When pilot signal pressure is supplied to the pilot port and 10.3 Δ bar [150 psi] is reached, the selector valve overcomes return spring force and the shifts the spool to select HSLT mode.

Oil on the opposite side of the spool is drained to tank via the drain port. The pressure difference between the pilot port and drain port must be maintained to keep

the motor in the high speed mode. When pilot pressure is removed from the pilot port, the pressure in the pilot end of the spool valve is relieved and drained back through the control valve and the return spring forces the spool valve to LSHT position.

Pilot pressure may come from any source that will provide uninterrupted pressure during the high-speed mode operation. Allowable pilot pressure must be at least 3.5 Δ bar [50 psi] and may be as high as full operating pressure of the motor.

Performance Data

In the LSHT mode, torque and speed values are equal to those of the conventional HP30 motor (refer to single-speed motor performance data). In the HSLT mode, rotation speed is increased by fifty percent and torque output is reduced by one third. The HP30 two-speed

motor will function with equal shaft output in either rotation direction (CW or CCW) in both LSHT and HSLT modes.

Typical Hydraulic Circuit

Two-Speed

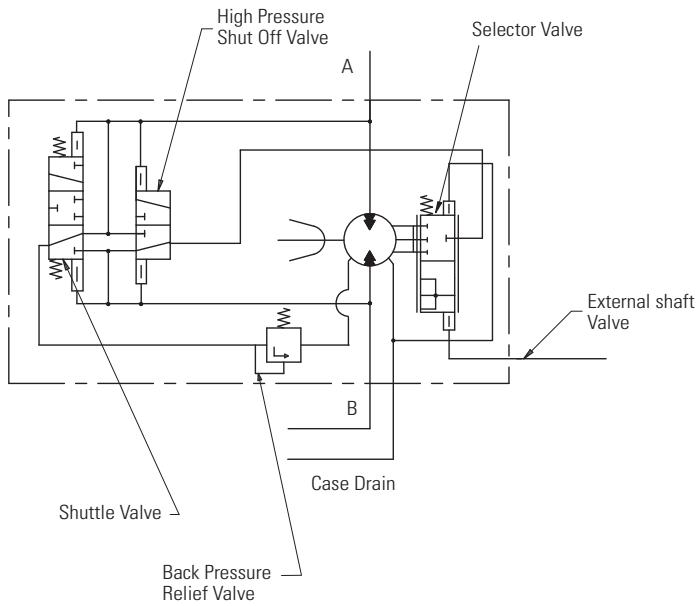
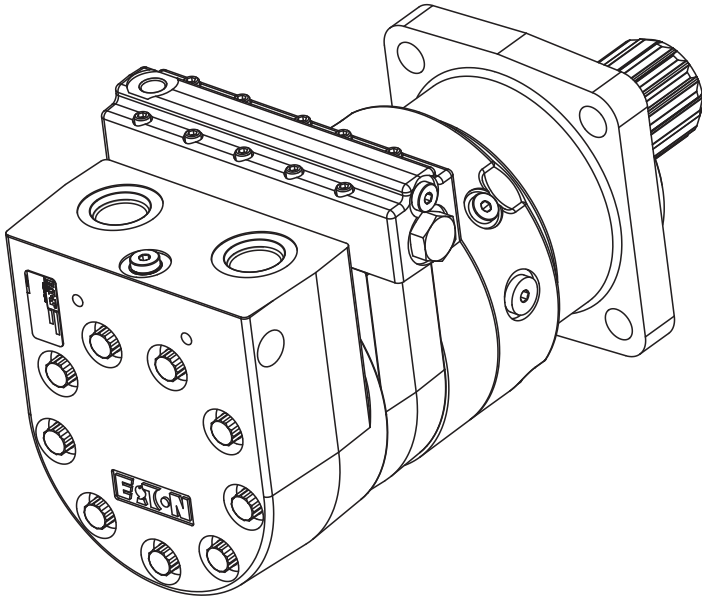

Note: The schematic diagram applies to HP30 series two-speed motors.

Specifications

Two-Speed

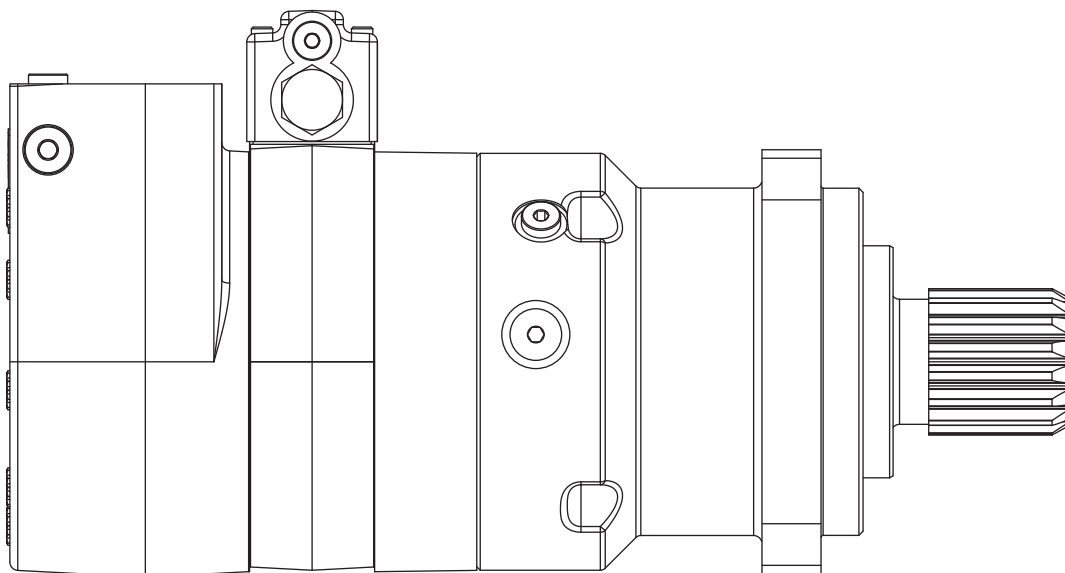

HP30 Series Motors, Two-Speed

Disp. cm ³ /r [in ³ /r]	High Speed Mode	229 [14.0]	267 [16.3]	289 [17.7]	320 [19.5]	451 [27.5]
	Low Speed Mode	344 [21.0]	400 [24.4]	434 [26.5]	480 [29.3]	677 [41.3]
Max. Speed [rpm] @ Continuous Flow	High Speed Mode	743	639	588	532	378
	Low Speed Mode	495	426	392	355	252
Flow l/min [gpm]	High Speed Mode	170 [45]	170 [45]	170 [45]	170 [45]	170 [45]
	Low Speed Mode	170 [45]	170 [45]	170 [45]	170 [45]	170 [45]
Torque* Nm [lb-in]	High Speed Mode					
	Continuous	1,076 [9,525]	1,251 [11,067]	1,358 [12,020]	1,501 [13,290]	1,646 [14,571]
	Intermittent	1,196 [10,584]	1,389 [12,297]	1,509 [13,356]	1,669 [14,767]	1,929 [17,068]
Torque* Nm [lb-in]	Low Speed Mode					
	Continuous	1,614 [14,288]	1,876 [16,600]	2,037 [18,030]	2,252 [19,935]	2,469 [21,856]
	Intermittent	1,794 [15,876]	2,084 [18,446]	2,263 [20,034]	2,503 [22,150]	2,893 [25,602]
Pressure Δ bar [Δ psi]	Continuous	310 [4,500]	310 [4,500]	310 [4,500]	310 [4,500]	241 [3,500]
	Intermittent	345 [5,000]	345 [5,000]	345 [5,000]	345 [5,000]	283 [4,100]
	Peak	379 [5,500]	379 [5,500]	379 [5,500]	379 [5,500]	379 [5,500]
Weight kg [lb]	Standard Mount	391 [86.2]	398 [87.6]	402 [88.5]	406 [89.5]	426 [93.8]
	Wheel Mount	419 [92.4]	426 [93.8]	429 [94.6]	434 [95.7]	454 [99.9]

*See shaft torque ratings for limitations.

Note: To assure best motor life, run motor for approximately one hour at 30% of rated pressure before application to full load. Be sure motor is filled with fluid prior to any load applications.

Maximum Inlet Pressure:

405 bar [5850 psi]

Do not exceed Δ pressure rating (see chart above).

Maximum Return Pressure:

405 bar [5850 psi] with case drain installed.

Do not exceed Δ pressure rating (see chart above).

Maximum Case Pressure:

20 bar [300 psi]

Δ bar [Δ psi] :

The true pressure difference between inlet port and outlet port.

Continuous Rating:

Motor may be run continuously at these ratings.

Intermittent Operation:

10% of every minute.

Peak Operation:

1% of every minute.

Recommended Fluids:

Premium quality, anti-wear type hydraulic oil with a viscosity of not less than 13 cSt [70 SUS] at operating temperature.

Recommended Maximum System Operating Temp.:

82°C [180°F]

Recommended Filtration:

Per ISO Cleanliness Code, 4406: 20/18/13.

Dimensions

Two-Speed Standard Mount

Main Ports

1-1/16-12 UN-2B SAE O-ring Ports (2)

9/16-18 UNF-2B SAE O-ring Case Drain Port (1)

or

G1 (BSP) O-ring Ports (2)

G1/4 (BSP) O-ring Case Drain Port (1)

Standard Rotation Viewed from Shaft End

Port A Pressurized – CW

Port B Pressurized – CCW

Closed Loop

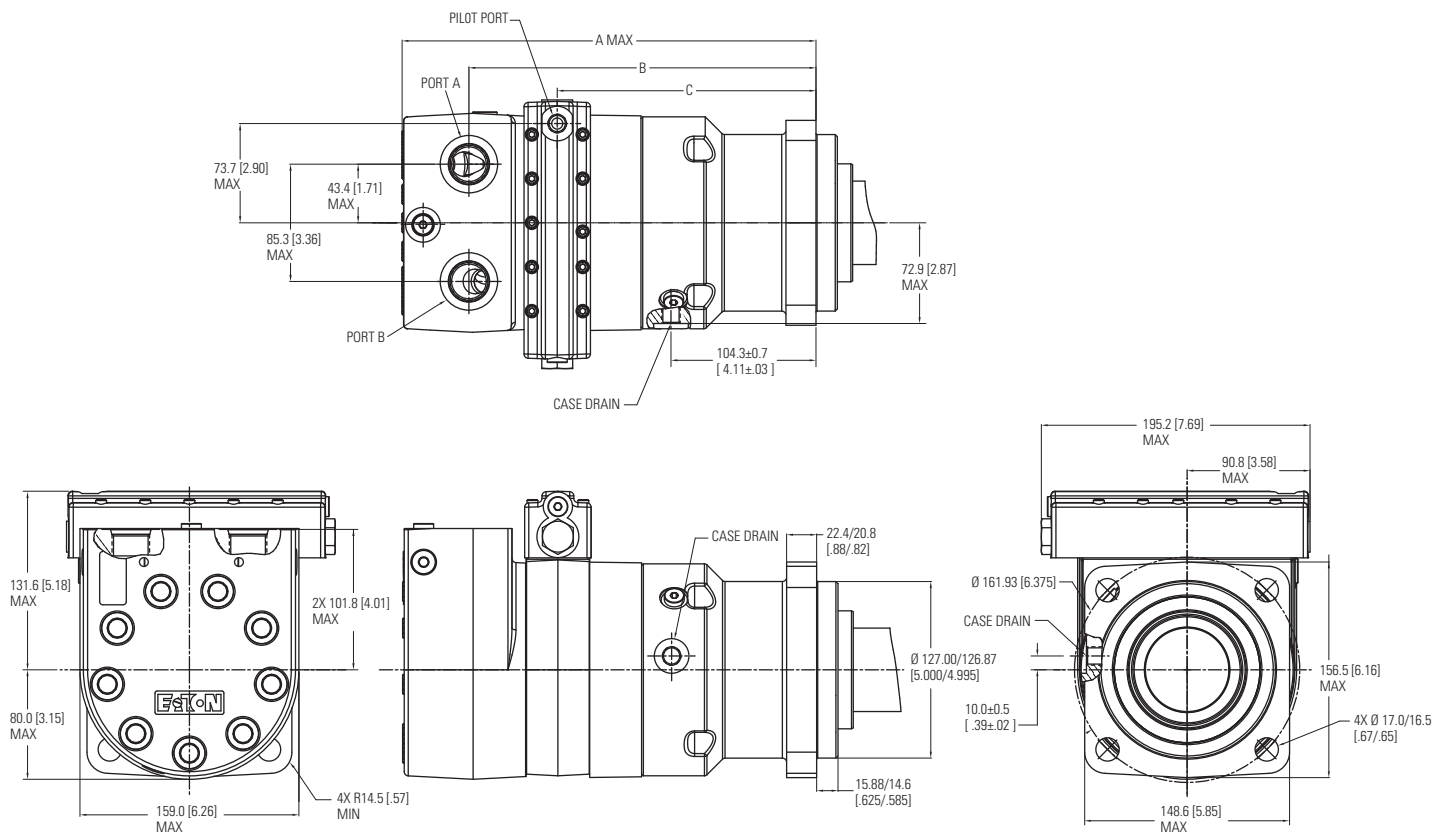

Motor Dimensions – Standard Mount

Displacement cm ³ /r [in ³ /r]	A Max mm [in]	B mm [in]	C mm [in]
344 [21.0]	293.9 [11.57]	244.3 [9.62]	180.8 [7.12]
400 [24.4]	299.1 [11.78]	249.6 [9.83]	186.1 [7.33]
434 [26.5]	302.4 [11.91]	252.8 [9.95]	189.3 [7.45]
480 [29.3]	306.5 [12.07]	256.9 [10.12]	193.4 [7.62]
677 [41.3]	325.0 [12.80]	275.4 [10.84]	211.9 [8.34]

Dimensions

Two-Speed Standard Mount

Main Ports

1-1/16-12 UN-2B SAE O-ring Ports (2)

9/16-18 UNF-2B SAE O-ring Case Drain Port (1)

or

G1 (BSP) O-ring Ports (2)

G1/4 (BSP) O-ring Case Drain Port (1)

Standard Rotation Viewed from Shaft End

Port A Pressurized – CW

Port B Pressurized – CCW

Open Loop

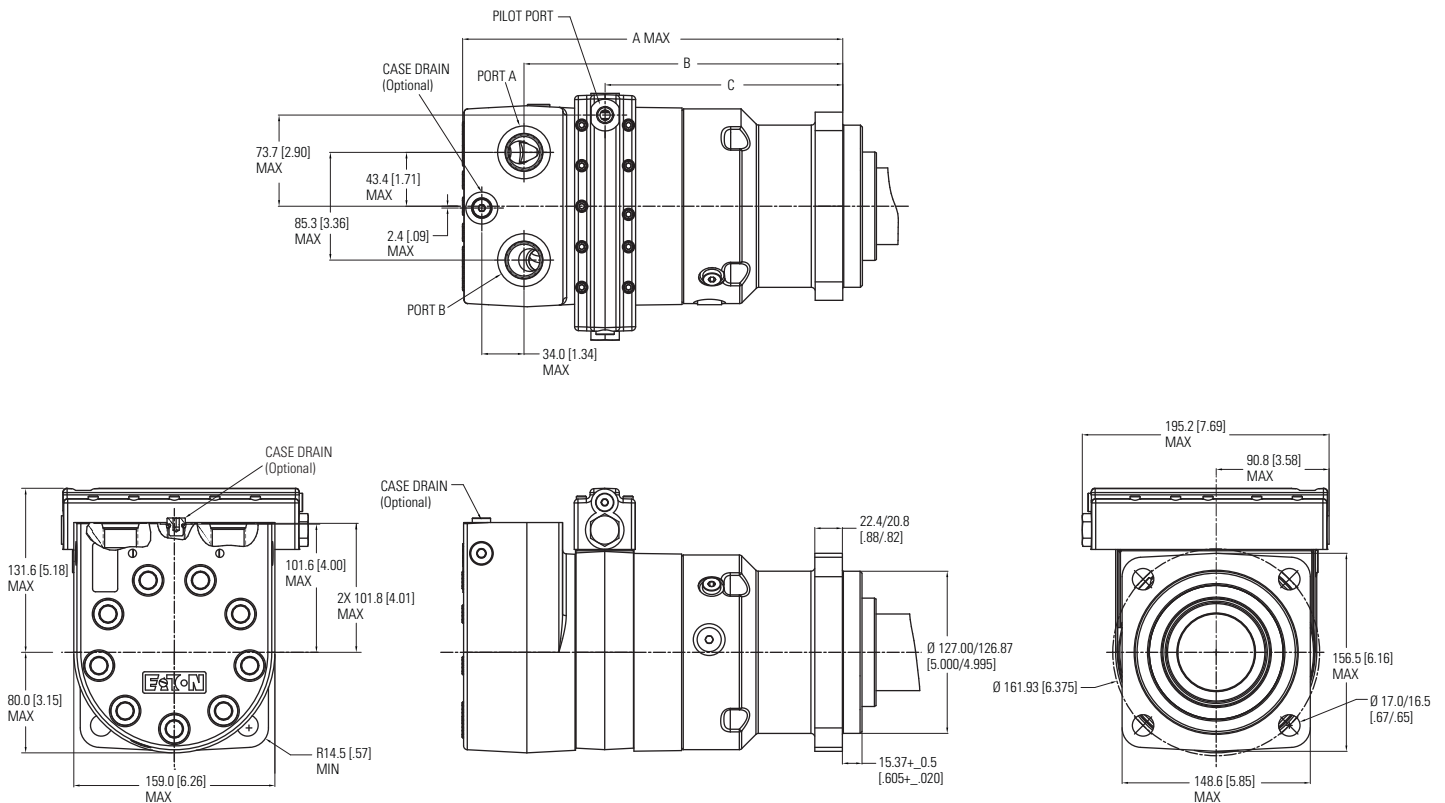

Motor Dimensions – Standard Mount

Displacement cm ³ /r [in ³ /r]	A Max mm [in]	B mm [in]	C mm [in]
344 [21.0]	293.9 [11.57]	244.3 [9.62]	180.8 [7.12]
400 [24.4]	299.1 [11.78]	249.6 [9.83]	186.1 [7.33]
434 [26.5]	302.4 [11.91]	252.8 [9.95]	189.3 [7.45]
480 [29.3]	306.5 [12.07]	256.9 [10.12]	193.4 [7.62]
677 [41.3]	325.0 [12.80]	275.4 [10.84]	211.9 [8.34]

Note: Use of a Case Drain is optional in an open loop circuit if motor case pressure does not exceed 300 psi.

Dimensions

Two-Speed Wheel Mount

Main Ports

1-1/16-12 UN-2B SAE O-ring Ports (2)

9/16-18 UNF-2B SAE O-ring Case Drain Port (1)

or

G1 (BSP) O-ring Ports (2)

G1/4 (BSP) O-ring Case Drain Port (1)

Standard Rotation Viewed from Shaft End

Port A Pressurized – CW

Port B Pressurized – CCW

Closed Loop

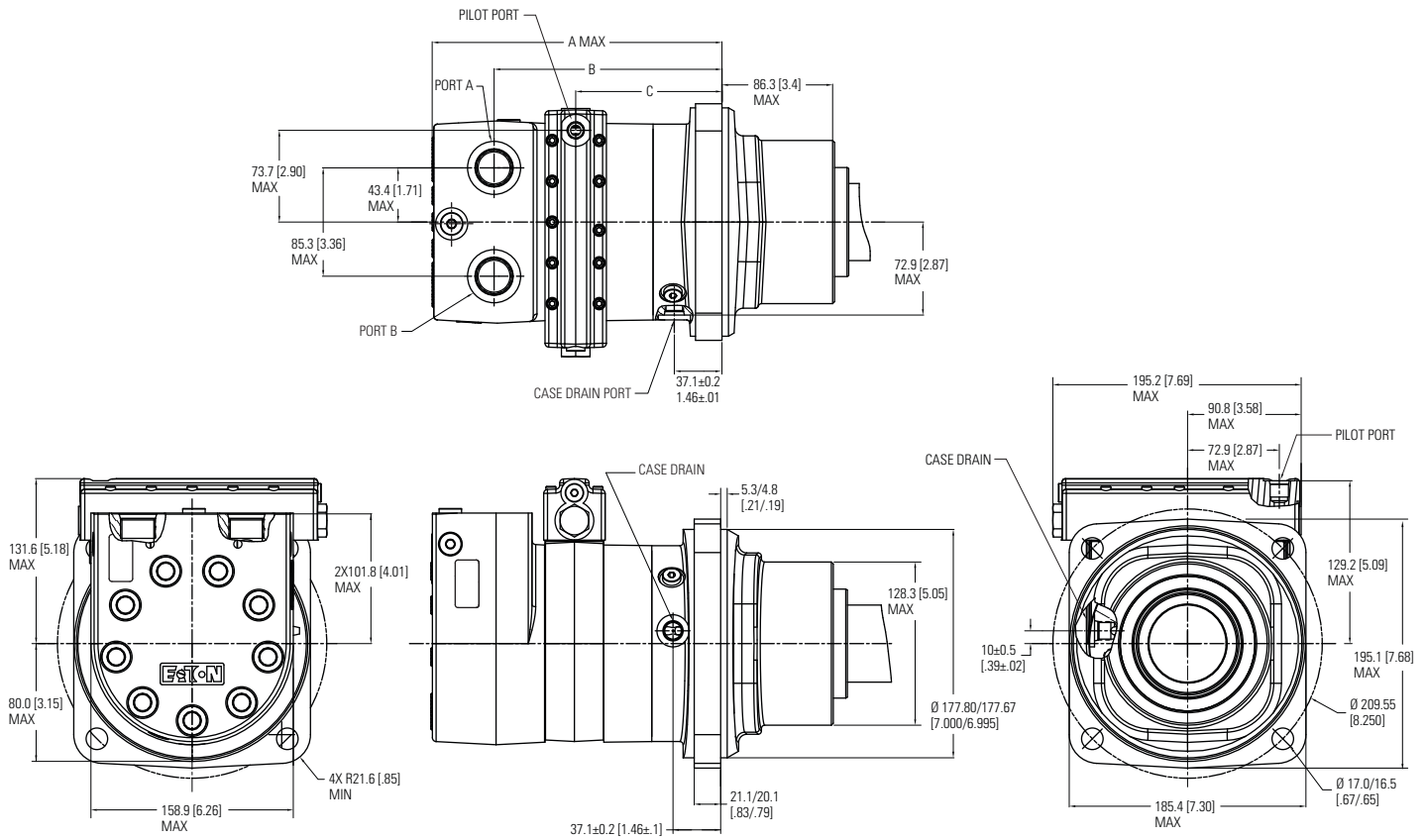

Motor Dimensions – Wheel Mount

Displacement cm ³ /r [in ³ /r]	A Max mm [in]	B mm [in]	C mm [in]
344 [21.0]	221.3 [8.71]	172.0 [6.77]	108.6 [4.28]
400 [24.4]	226.6 [8.92]	177.3 [6.98]	113.9 [4.49]
434 [26.5]	229.9 [9.05]	180.5 [7.11]	117.0 [4.61]
480 [29.3]	234.0 [9.21]	184.7 [7.27]	121.3 [4.78]
677 [41.3]	252.5 [9.94]	203.2 [8.00]	139.6 [5.50]

Dimensions

Two-Speed Wheel Mount

Main Ports

1-1/16-12 UN-2B SAE O-ring Ports (2)

9/16-18 UNF-2B SAE O-ring Case Drain Port (1)

or

G1 (BSP) O-ring Ports (2)

G1/4 (BSP) O-ring Case Drain Port (1)

Standard Rotation Viewed from Shaft End

Port A Pressurized – CW

Port B Pressurized – CCW

Open Loop

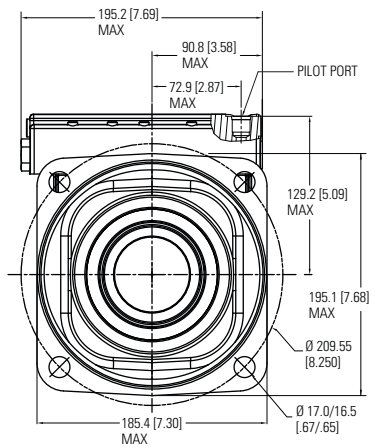
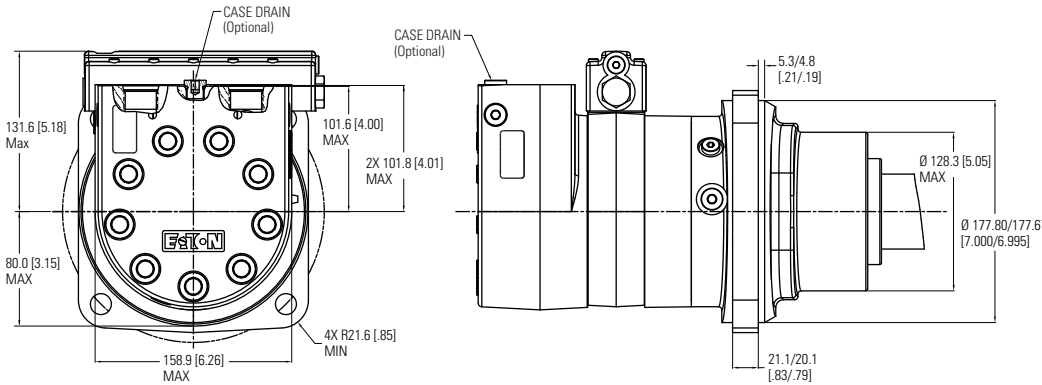
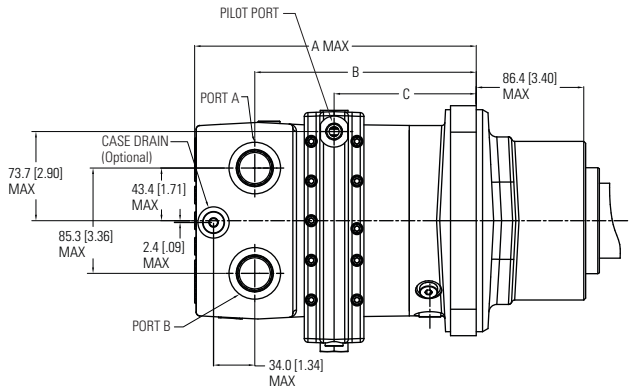

Motor Dimensions – Wheel Mount

Displacement cm ³ /r [in ³ /r]	A Max mm [in]	B mm [in]	C mm [in]
344 [21.0]	221.3 [8.71]	172.0 [6.77]	108.6 [4.28]
400 [24.4]	226.6 [8.92]	177.3 [6.98]	113.9 [4.49]
434 [26.5]	229.9 [9.05]	180.5 [7.11]	117.0 [4.61]
480 [29.3]	234.0 [9.21]	184.7 [7.27]	121.3 [4.78]
677 [41.3]	252.5 [9.94]	203.2 [8.00]	139.6 [5.50]

Note: Use of a Case Drain is optional in an open loop circuit if motor case pressure does not exceed 300 psi.

Dimensions

Two-Speed Bearingless

Main Ports

1-1/16-12 UN-2B SAE O-ring Ports (2)

9/16-18 UNF-2B SAE O-ring Case Drain Port (1)

or

G1 (BSP) O-ring Ports (2)

G1/4 (BSP) O-ring Case Drain Port (1)

Standard Rotation Viewed from Drive End

Port A Pressurized — CW

Port B Pressurized — CCW

Closed Loop

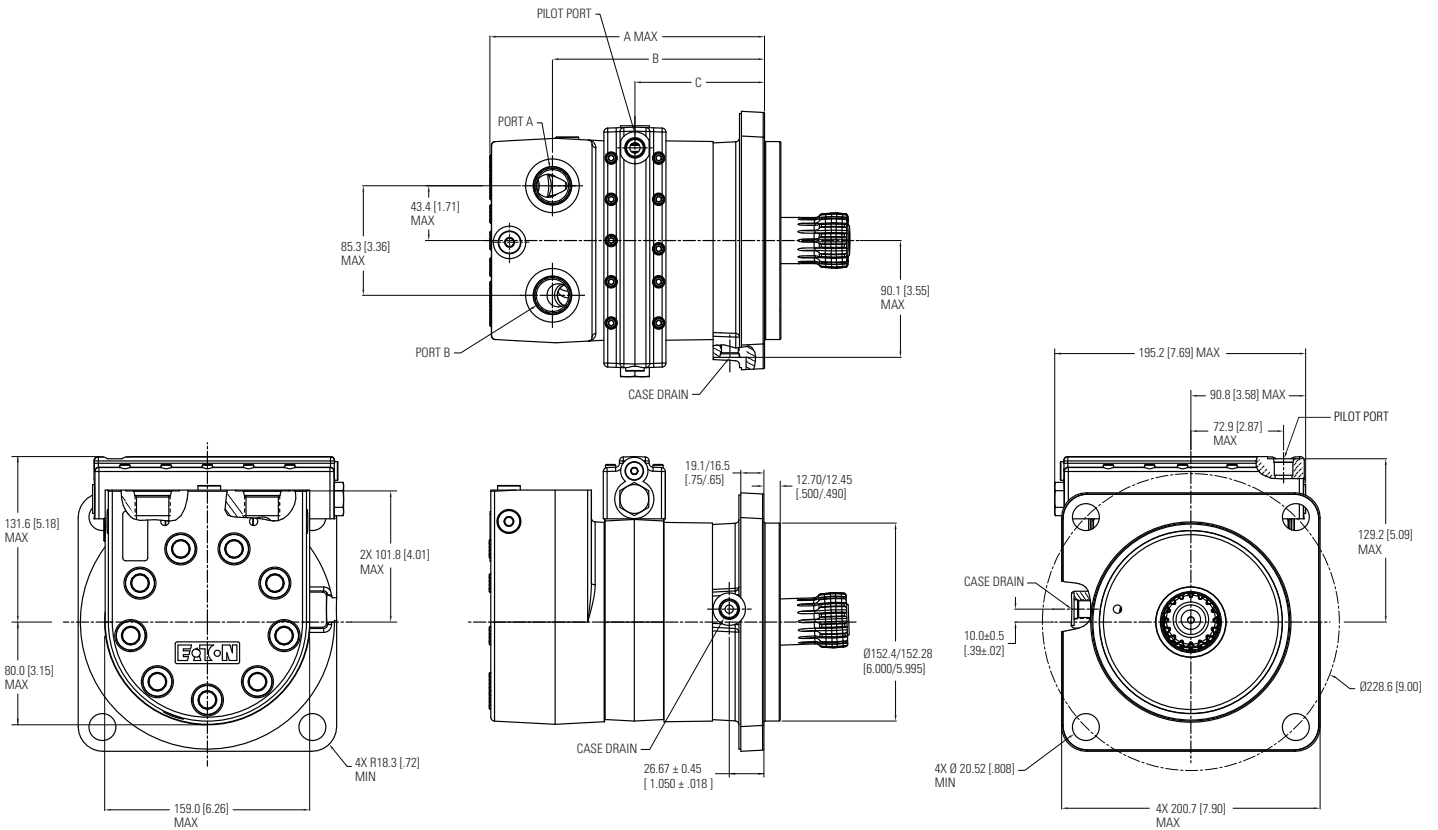

Motor Dimensions – Bearingless Mount

Displacement cm ³ /r [in ³ /r]	A Max mm [in]	B mm [in]	C mm [in]
344 [21.0]	207.1 [8.15]	158.0 [6.22]	94.5 [3.72]
400 [24.4]	212.3 [8.36]	163.3 [6.43]	99.8 [3.93]
434 [26.5]	215.6 [8.49]	166.5 [6.56]	103.1 [4.06]
480 [29.3]	219.7 [8.65]	170.6 [6.72]	107.2 [4.22]
677 [41.3]	238.2 [9.38]	189.2 [7.45]	125.7 [4.95]

Dimensions

Two-Speed Bearingless

Main Ports

- 1-1/16-12 UN-2B SAE O-ring Ports (2)
- 9/16-18 UNF-2B SAE O-ring Case Drain Port (1)
- or
- G1 (BSP) O-ring Ports (2)
- G1/4 (BSP) O-ring Case Drain Port (1)

Standard Rotation Viewed from Drive End

- Port A Pressurized — CW
- Port B Pressurized — CCW

Open Loop

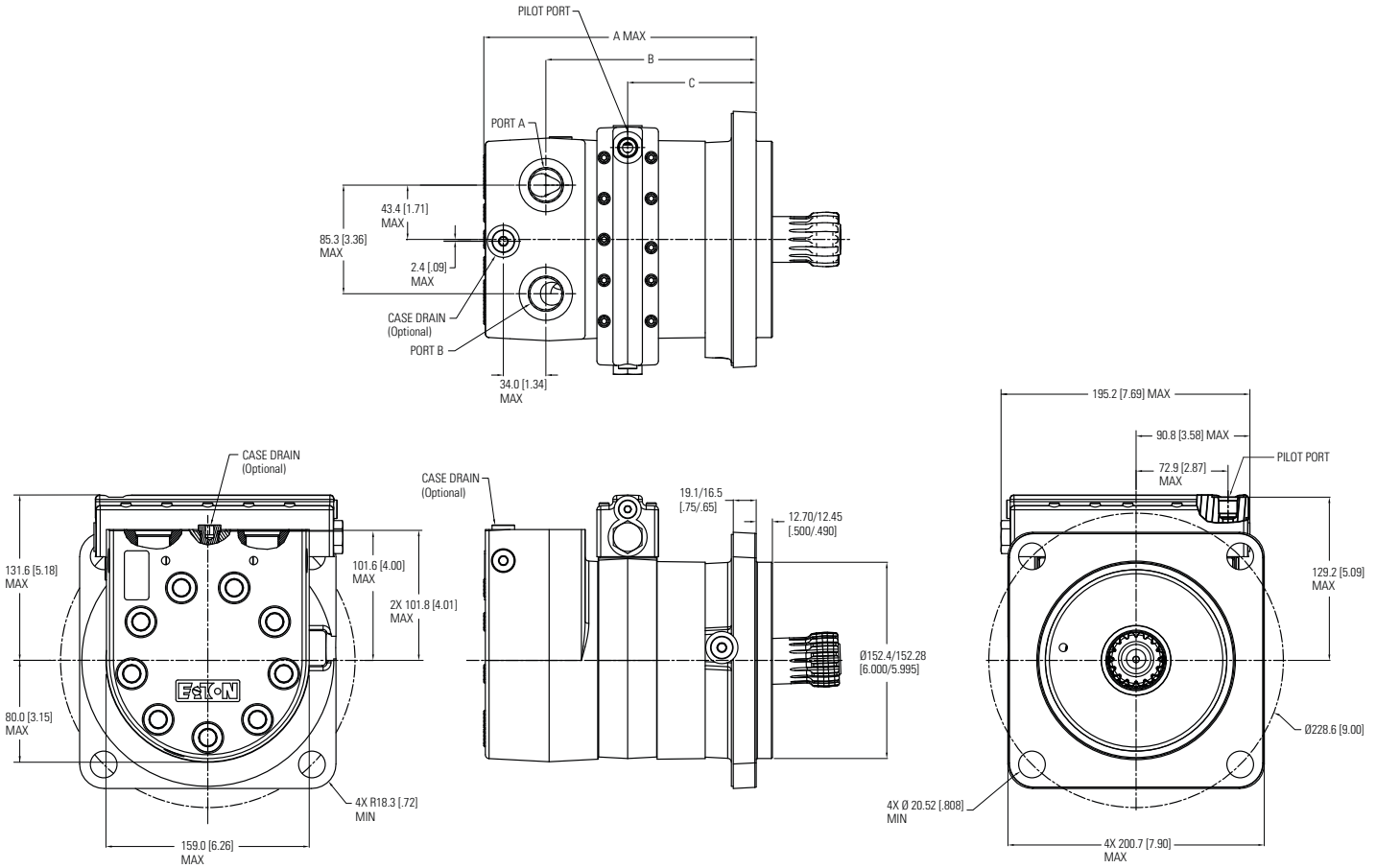

Motor Dimensions – Bearingless Mount

Displacement cm ³ /r [in ³ /r]	A Max mm [in]	B mm [in]	C mm [in]
344 [21.0]	207.1 [8.15]	158.0 [6.22]	94.5 [3.72]
400 [24.4]	212.3 [8.36]	163.3 [6.43]	99.8 [3.93]
434 [26.5]	215.6 [8.49]	166.5 [6.56]	103.1 [4.06]
480 [29.3]	219.7 [8.65]	170.6 [6.72]	107.2 [4.22]
677 [41.3]	238.2 [9.38]	189.2 [7.45]	125.7 [4.95]

Note: Use of a Case Drain is optional in an open loop circuit if motor case pressure does not exceed 300 psi.

Typical Hydraulic Circuit

HP30

Shuttle Valve, Two Way (Closed Center) — Schematic Diagrams

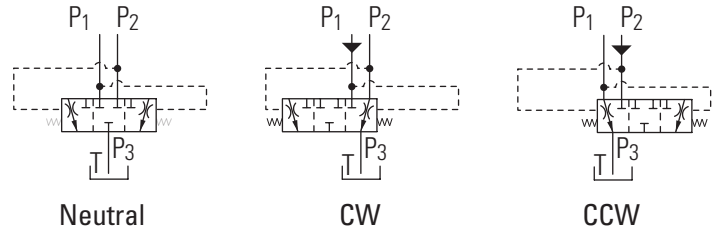

Closed Loop Circuit

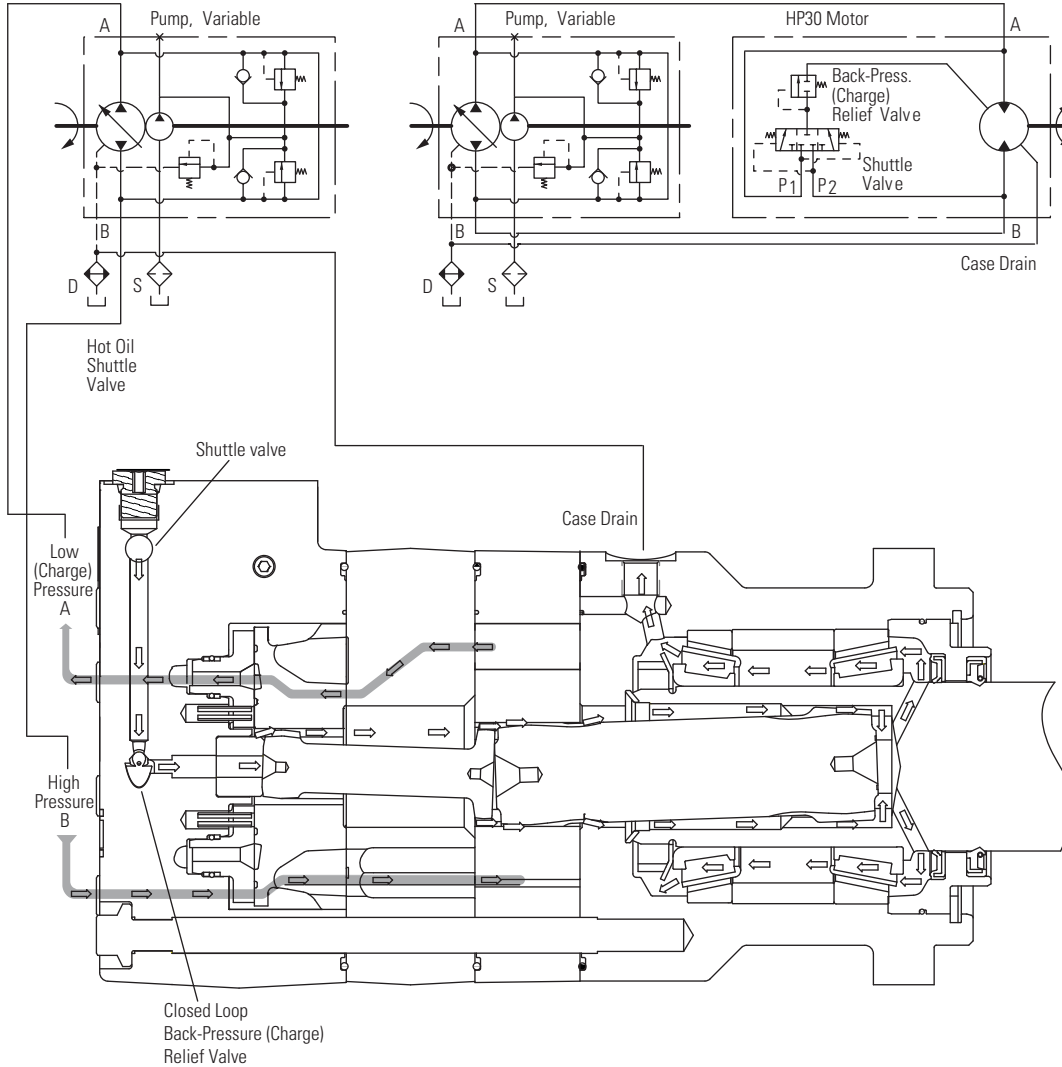

HP30 Motors Shuttle Flow Charts

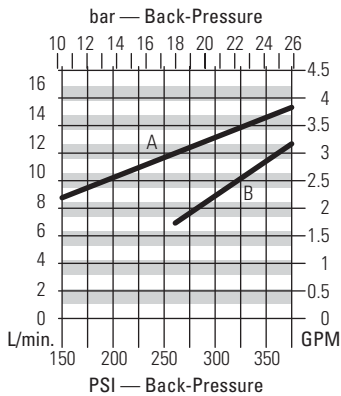

- A**
4,5 bar [65 PSI] @ 60° C [140° F]
Δ Between Back-Pressure and Case Pressure (Typical Data)
- B**
15,2 bar [220 PSI] @ 60° C [140° F]
Δ Between Back-Pressure and Case Pressure (Typical Data)
Due to Machining Tolerances, Flow May be More or Less

Note: Closed loop circuits must have a shuttle valve configuration. See model code position 15, 16 "Case Flow Option."

Note: HP30 motors applied in closed loop circuit applications must have a case drain line to tank. Without this drain line the internal drive spline will not have adequate lubrication.

Typical Hydraulic Circuit

HP30

Open Loop Circuit

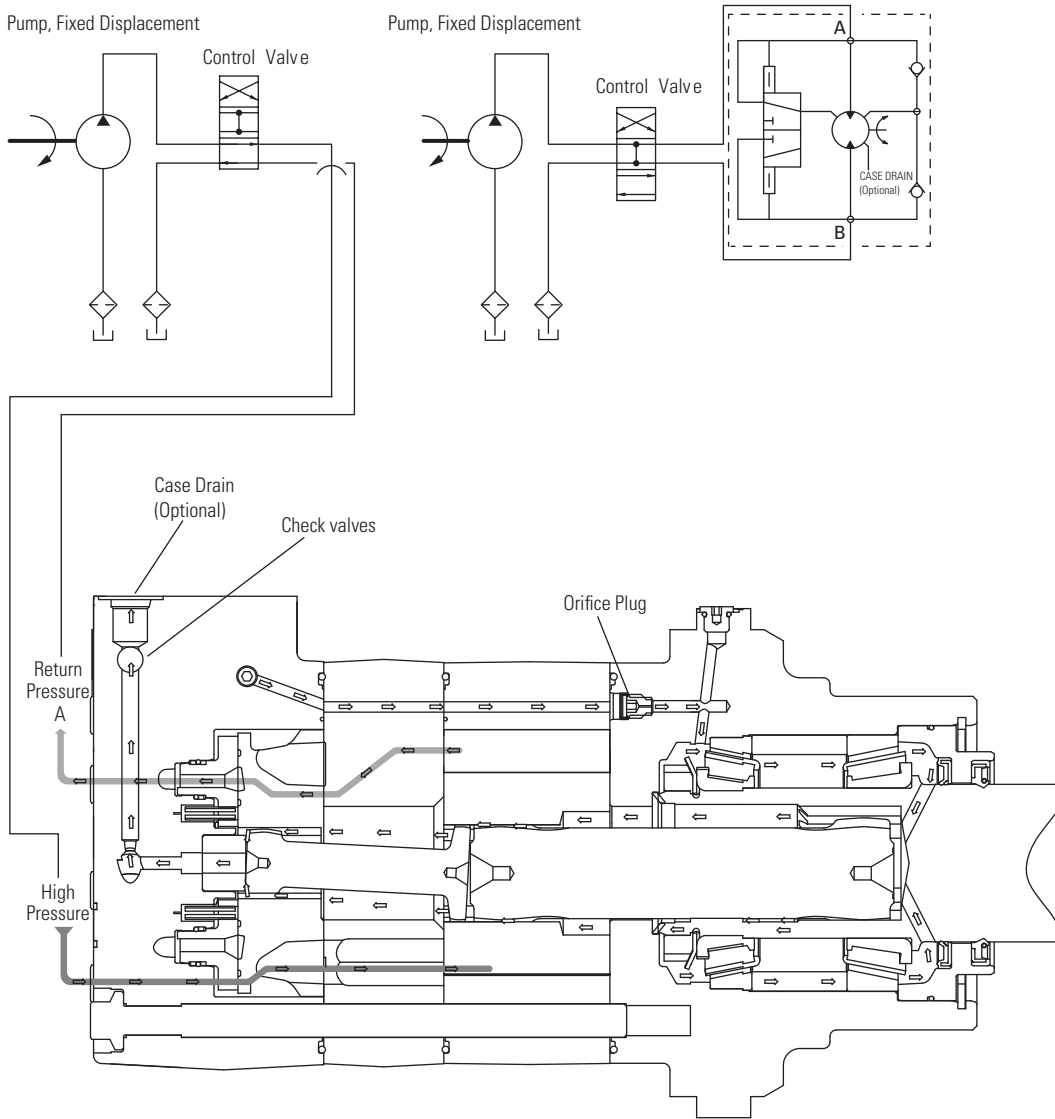

HP30 Motor is Series Circuit capable.

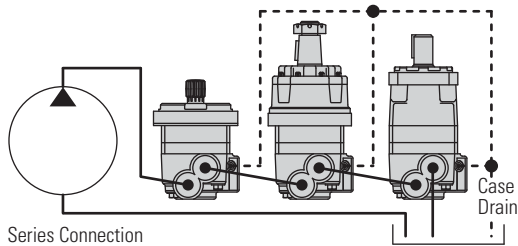

Note: Open loop circuits must have a check valve with orifice plug configuration. See model code position 15, 16 "Case Flow Option."

Note: Use of a Case Drain is optional in an open loop circuit if motor case pressure does not exceed 300 psi.

Typical Hydraulic Circuit

HP30

Two-Speed Circuit

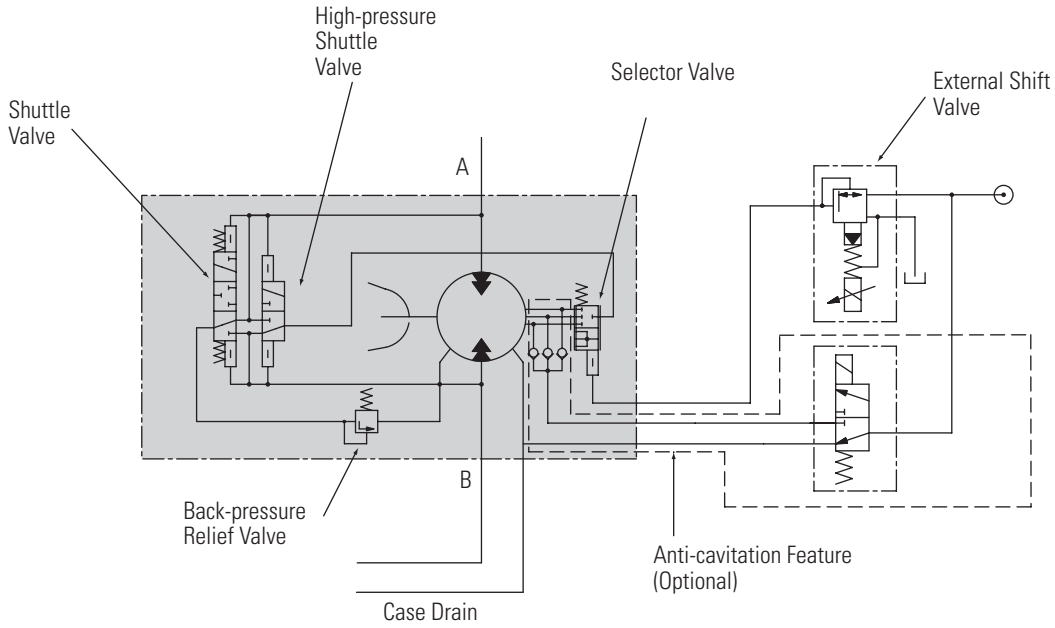

Two-Speed Brake Motor Circuit

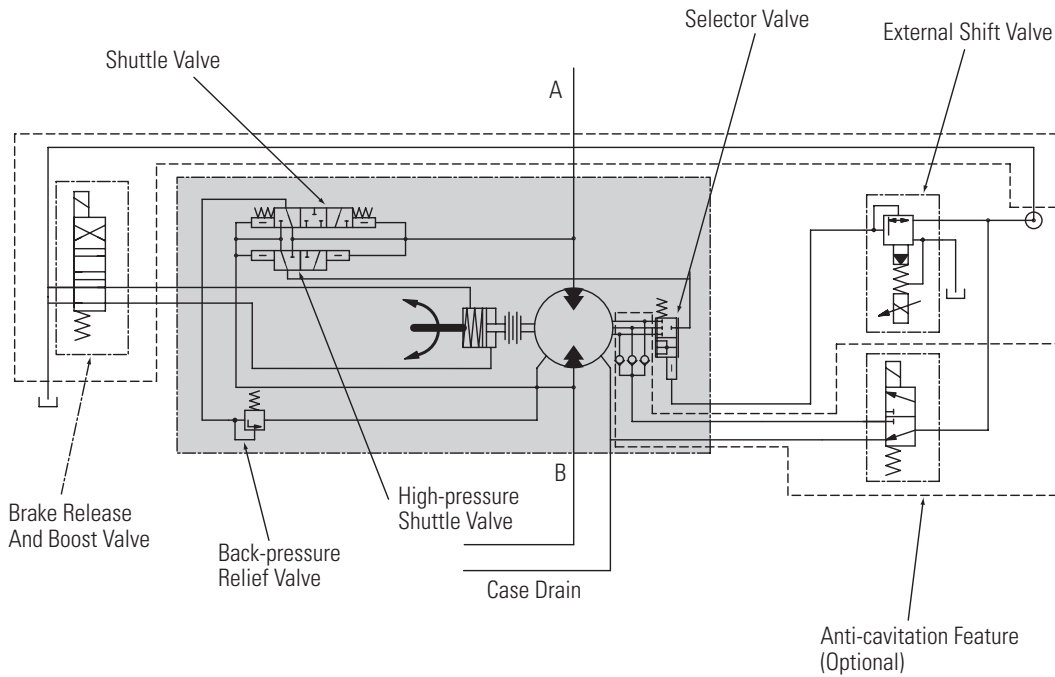

Description

Brake Motor

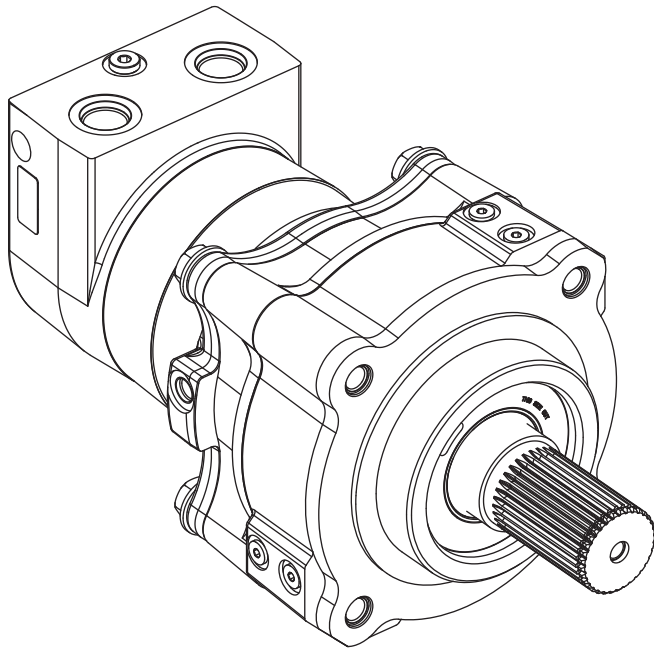

Features

- Spring-applied/hydraulically released multi-disc brake
- Spring automatically applies brake when hydrostatic pressure is absent
- Environmentally protected
- Integral design – motor and brake as a single package to minimize length and cost
- Infinite braking – eliminates machine creep associated with park pawl mechanisms
- Boost feature – increases holding capacity to match full motor output torque
- No adjustments needed
- Two sets of release and boost ports – allows for multiple plumbing options and facilitates bleeding

Applications

- Skid steer loaders
- Trenchers
- Road rollers
- Anywhere load-holding is needed on a low-speed high-torque drive system

Specifications

- Static holding – 780 N-m [6900 lb-in] minimum torque (spring only - no boost) 2621 N-m [23200 lb-in] minimum (@ 10.3 bar [150 psi boost] 3570 N-m [31600 lb-in] minimum (@ 15.2 bar [220 psi boost])
- Release pressure – 10.3 bar [150 psi] minimum for full release 68.9 bar [1000 psi] maximum allowed at release port
- Case pressure – 1.4 bar [20 psi] continuous 3.5 bar [50 psi] maximum
- Boost pressure – 15.2 bar [220 psi] continuous 34.5 bar [500 psi] maximum
- Speed – 360 rpm maximum
- Emergency – After 3 consecutive stops, brake to still meet parking requirement

Dimensions

Brake Motor Single-Speed

Main Ports

1-1/16-12 UN-2B SAE O-ring Ports (2)

9/16-18 UNF-2B SAE O-ring Case Drain Port (1)

or

G1 (BSP) O-ring Ports (2)

G1/4 (BSP) O-ring Case Drain Port (1)

Standard Rotation Viewed from Shaft End

Port A Pressurized – CW

Port B Pressurized – CCW

Closed Loop

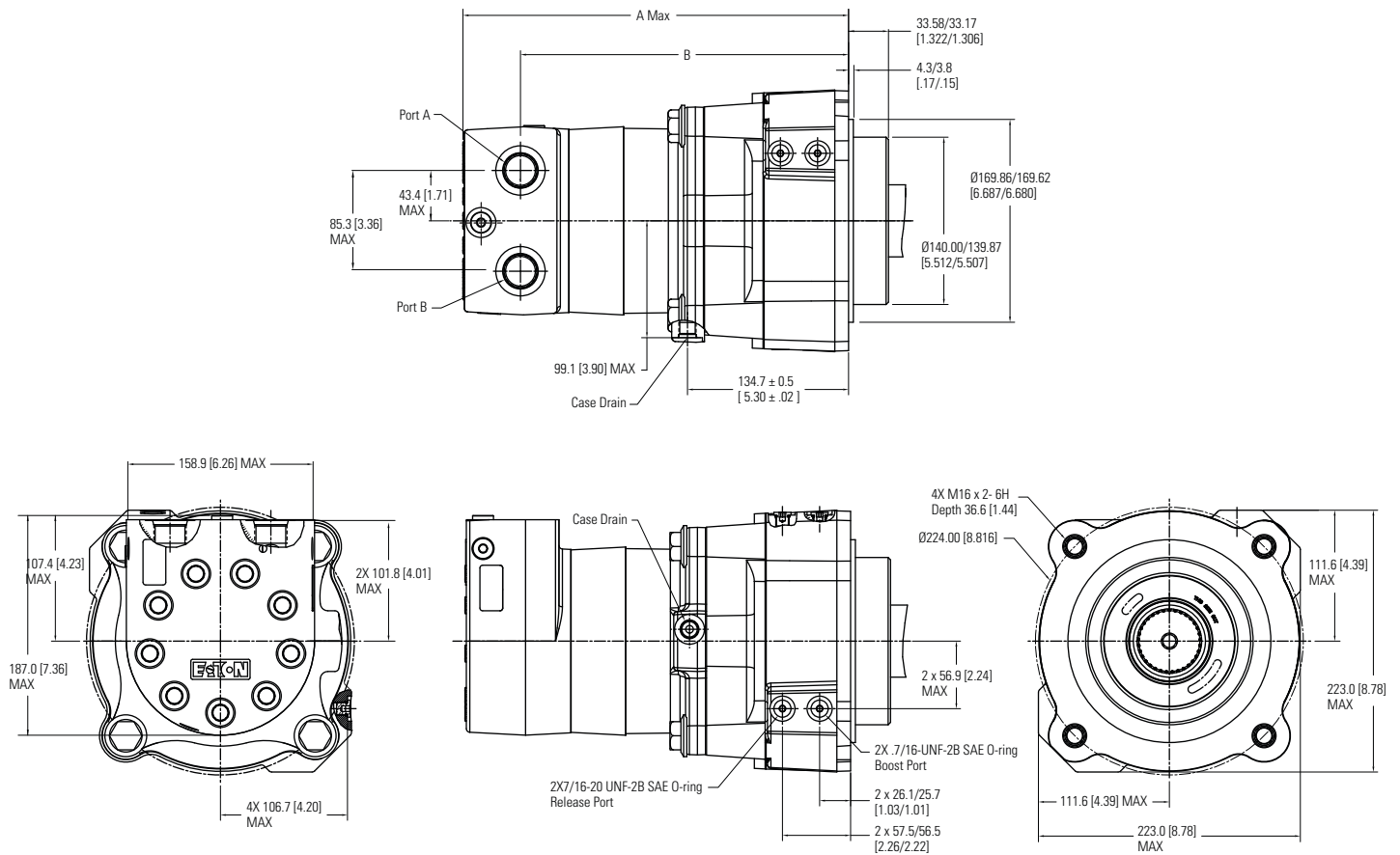

Brake Motor Dimensions – Single-Speed

Displacement cm ³ /r [in ³ /r]	A Max		B	
	mm	[in]	mm	[in]
344 [21.0]	318.5	[12.54]	269.1	[10.60]
400 [24.4]	323.8	[12.75]	272.2	[10.80]
434 [26.5]	327.2	[12.88]	277.7	[10.93]
480 [29.3]	331.1	[13.04]	281.8	[11.09]
677 [41.3]	349.7	[13.77]	300.3	[11.82]

Dimensions

Brake Motor Two-Speed

Main Ports

- 1-1/16-12 UN-2B SAE O-ring Ports (2)
- 9/16-18 UNF-2B SAE O-ring Case Drain Port (1)
- or
- G1 (BSP) O-ring Ports (2)
- G1/4 (BSP) O-ring Case Drain Port (1)

Standard Rotation Viewed from Shaft End

- Port A Pressurized – CW
- Port B Pressurized – CCW

Closed Loop

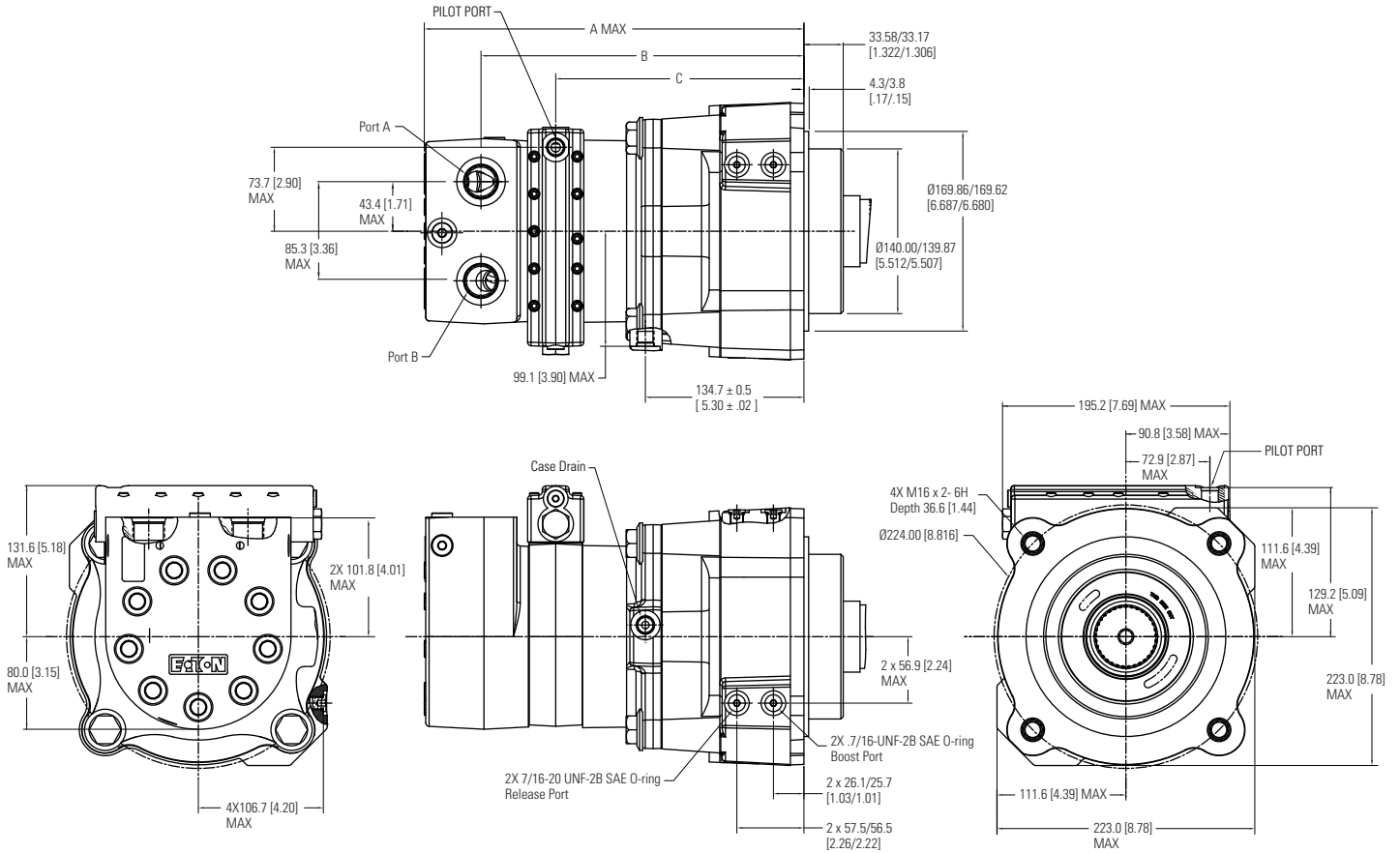

Brake Motor Dimensions – Two-Speed

Displacement cm ³ /r [in ³ /r]	A Max mm [in]	B mm [in]	C mm [in]
344 [21.0]	318.5 [12.54]	269.1 [10.60]	205.6 [8.10]
400 [24.4]	323.8 [12.75]	274.4 [10.80]	210.9 [8.30]
434 [26.5]	327.2 [12.88]	277.7 [10.93]	214.2 [8.43]
480 [29.3]	331.1 [13.04]	281.8 [11.09]	218.3 [8.59]
677 [41.3]	349.7 [13.77]	300.3 [11.82]	236.8 [9.32]

Dimensions

Brake Shaft Side Load Capacity

These curves indicate the radial load capacity on the motor shaft at various locations with an allowable external thrust load of 454 kg [1,000 lb].

Note: Case pressure will increase the allowable inward thrust load and decrease the allowable outward thrust load. Case pressure will push outward on the shaft at 100 kg/3.5 bar [222 lb/50 psi].

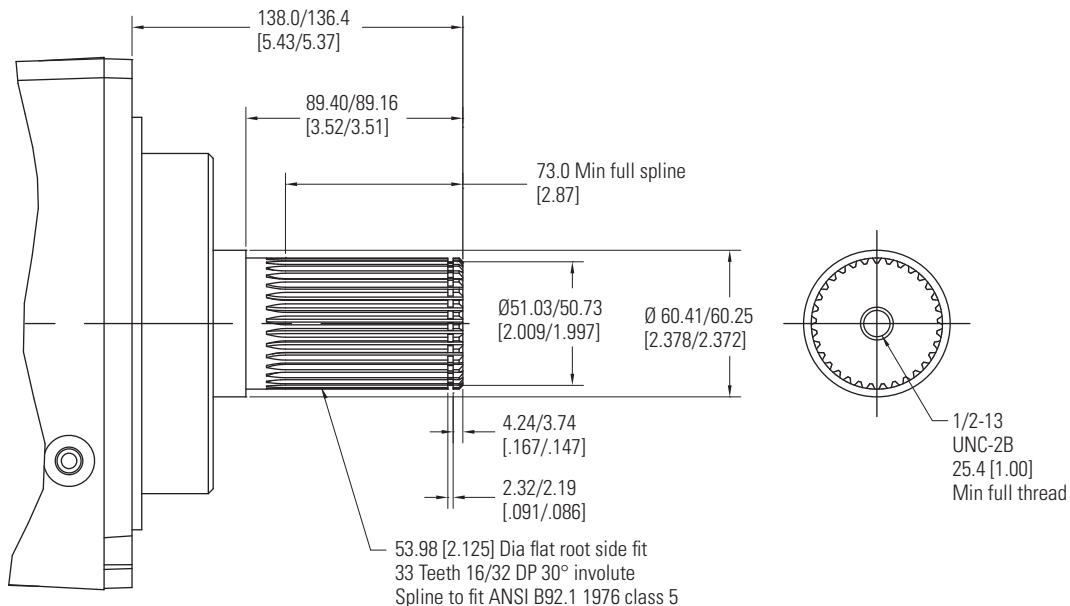
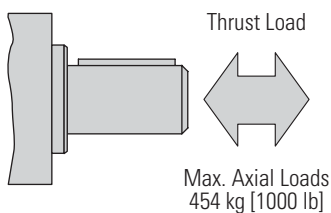

Each curve is based on B 10 bearing life [2000 hours of 12,000,000 shaft revolutions at 100 rpm] at rated output torque. To determine radial load at speeds other than 100 rpm, multiply the load values given on the bearing curve by the factors in the chart below.

rpm	Multiplication Factor
50	1.23
100	1.00
200	0.81
300	0.72
360	0.68

For 3,000,000 shaft revolutions or 500 hours – Increase these shaft loads 52%.

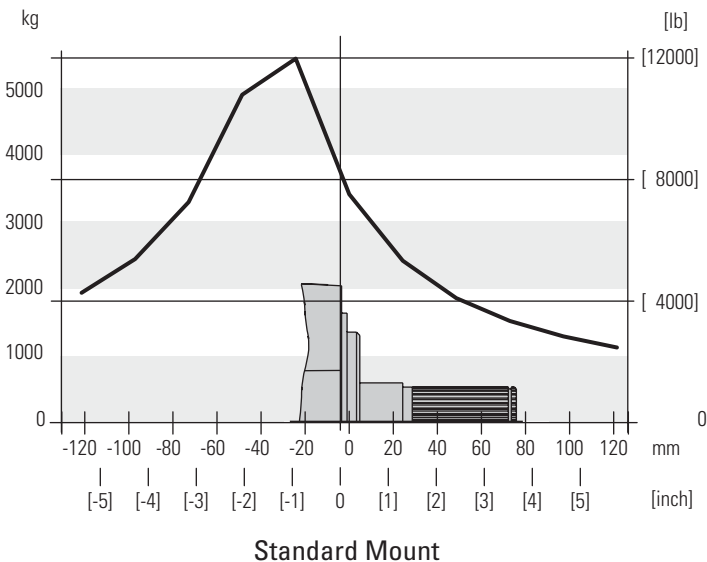

Eaton
Hydraulics Group USA
14615 Lone Oak Road
Eden Prairie, MN 55344
USA
Tel: 952-937-9800
Fax: 952-294-7722
www.eaton.com/hydraulics

Eaton
Hydraulics Group Europe
Route de la Longeraie 7
1110 Morges
Switzerland
Tel: +41 (0) 21 811 4600
Fax: +41 (0) 21 811 4601

Eaton
Hydraulics Group Asia Pacific
Eaton Building
No.7 Lane 280 Linhong Road
Changning District,
Shanghai 200335
China
Tel: (+86 21) 5200 0099
Fax: (+86 21) 2230 7240