

Vickers®

Service Data

Vane Pumps



Vane Type Double Pump

3520VQ Series - 20 Design



Revised 10-01-89

I-3169-S

MODEL	COVER TYPE	COVER S/A
3*2*VQ*A*-***20	4-BOLT	250824
3*2*VQ*E*-***20	STRAIGHT THREAD	252504
3*2*VQ*E*-**2*20	FLOW CONTROL	257560
3*2*VQ*E*-**4*20		257561
3*2*VQ*E*-**6*20		257562
3*2*VQ*E*-**7*20		257563
3*2*VQ*E*-**8*20		257564
3*2*VQ*E*-**10*20		257565
3*2*VQ*E*-**12*20		257999

MODEL	RELIEF VALVE SETTING (PSI)	RELIEF VALVE S/A
3*2*VQ***C20	750	232794
3*2*VQ***D20	1000	232795
3*2*VQ***E20	1250	232796
3*2*VQ***F20	1500	232797
3*2*VQ***G20	1750	232798
3*2*VQ***H20	2000	232799
3*2*VQ***J20	2250	233019
3*2*VQ***K20	2500	233020

**20VQ Models only not for 12 & 14 USgpm ring sizes.

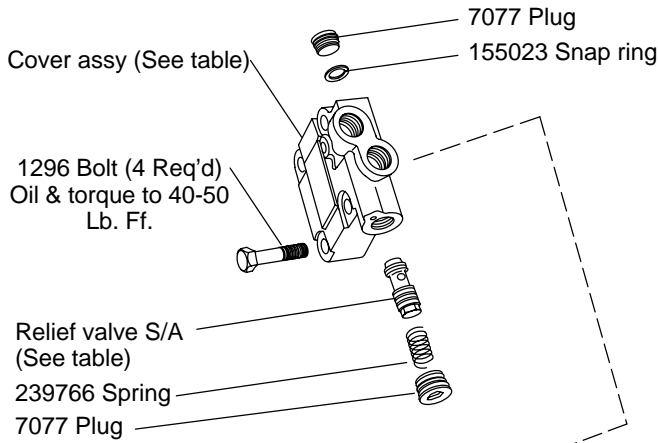

Wipe O.D. of seal with oil before pressing into body. apply grease to seal I.D. before installation of shaft.

***NOTE**
Install into cover before installation of cartridge kit.

NOTE
Use 3520VQ parts to service 3520V-10/-12 design units.

NOTE
Bronze faces must be installed toward the rotor.

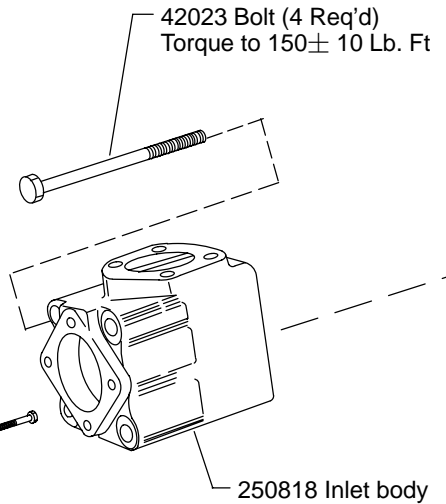

416426 Screw (2 Req'd)
Torque to 30 ± 5 Lb. In.

422206 Pin (2 Req'd)

Ring (See table)

Vane Kit (See table)

- ▲ 588506 Back-up ring
- ▲ 154026 "O" Ring
- ▲ 419672 Seal ring
- ▲ 154090 "O" Ring
- 419500 Outlet support plate
- ▲ 433762 S/A Seal pack (4 Req'd)
- 923955 Flex-side plate kit
- Rotor (See table)

Included in cover end cartridge kit

MODEL	ROTOR	Vane kit (10 vanes & 10 inserts)	RING	Inlet support plate	CART. KIT	F3 CART. KIT
3*20***5**	402690	922741	333624	419502	417053	421588
3*20***8**			333625		417054	421589
3*20***9**			374799		423096	423097
3*20***11*	403539	922743	333626	419501	416427	421590
3*20***12*			353901		416428	421591
3*20***14*			353902		416429	421592
3*21***5**◇			333624		428700	428707
3*21***8**◇	428698	922741	333625	419502	428701	428708
3*21***9**◇			374799		428702	428709
3*21***11**◇			333626		428703	428710
3*21***12**◇	428699	922743	353901	419501	428704	428711
3*21***14*◇			353902		428705	428712

◇ VQ REPLACEMENT CARTRIDGES FOR THE 3521 SERIES.

SHAFT NO.	TYPE	3*20 SHAFT	3*21 SHAFT	KEY
1	Str. keyed	258249	252717	88678
11	Spline	258250	252716	—
19	Spline	260604	251836	—
86	Str. keyed heavy duty	394517	—	393536

MODEL	TYPE DRIVE	BEARING
352*VQ	DIRECT-	38441
362*VQ	INDIRECT-	239092

● ASSEMBLE SEAL FLUSH TO PILOT FACE WITH SPRING FACING INWARD AS SHOWN.

○ ASSEMBLE SEAL WITH SPRING TOWARD BEARING.

MOUNTING ASSEMBLY 3*VQ***F.**.20(L)		
Included in foot bracket kit no.	Screw (2 req'd)	Mounting bracket
FB-C-10	205533	205077

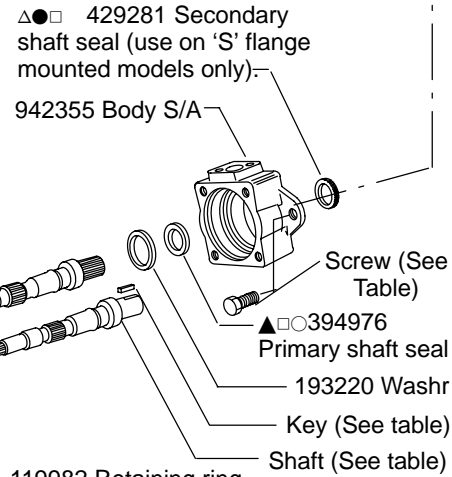
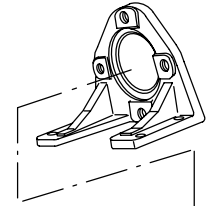

NOTE
Bronze faces must be installed toward the rotor.

- 410609 Screw (2 req'd)
Torque to 100 LB. IN.
- 418108 PIN (2 REQ'D)

- 430806 S/A
Inlet support plate
- ▲■ 433766 S/A Seal pack (4 req'd)

- Bearing (See table)
- 119982 Retaining ring
- 193144 Spirolox ring
- ▲ 588508 Back-up ring
- ▲ 154084 "O" RING
- *■▲ 419674 Seal ring
- ▲ 154101 "O" Ring
- 412003 Outlet support plate
- Ring (See table)
- 922700 Vane kit (10 vanes & 10 inserts)
- 262154 Rotor
- ◆ 923953 Flex-side plate kit

*Install seal ring in body or cover, then install cartridge kit.

- ▲ Std single shaft seal kit 920048
- △▲ Std doubleshaft seal kit 920049
- ▲F3 single shaft seal kit 920050
- △▲F3 double shaft seal kit 920051

■ Included in shaft end cartridge kit

■ **NOTE:** Flex sideplate kits include (4) F3 seal packs.

MODEL	■RING	CART. KIT	F3 CART. KIT
3*2*VQ21A	394961	413420	421582
3*2*VQ25A	319396	413421	421583
3*2*VQ30A	319397	413422	421584
3*2*VQ35A	319398	413418	421585
3*2*VQ38A	319399	413419	421586

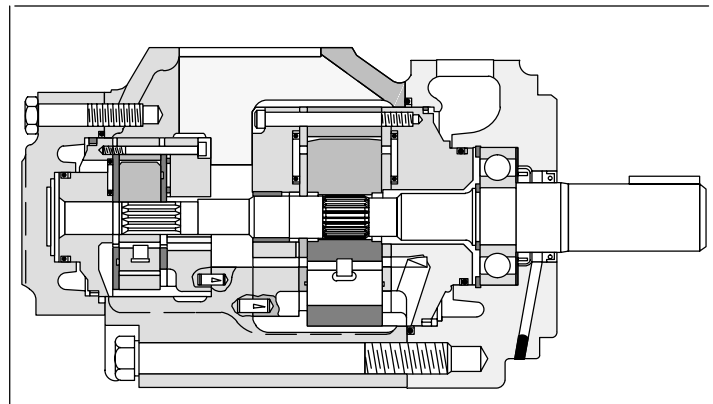

Model Code

(F3) - 3*2* VQ ** A ** - * 1 ** ** * 20 (*) - 28 *

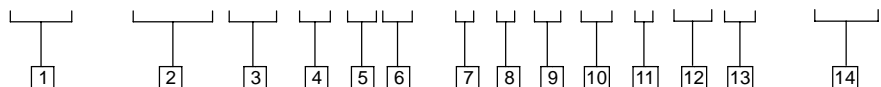

1 Viton seals
(Omit if not required.)

2 Series designation
3520VQ, Double Pump
3620VQ, Double Pump

3 Intra-vane pump

4 USgpm capacity
(Shaft end pump)

SAE rating 1200 rpm–100 psi (7 bar)

21 – 21 USgpm	35 – 35 USgpm
25 – 25 USgpm	38 – 38 USgpm
30 – 30 USgpm	

5 SAE port connections

Models Without Flow Control

Code	Inlet	Outlet #1	Outlet #2
A –	4 bolt flange	4 bolt flange	4 bolt flange
E –	4 bolt flange	4 bolt flange	SAE St. Thd.

Models With Flow Control

Code	Inlet	Outlet #1	Outlet #2	Tank Return
E –	4 bolt flange	4 bolt flange	SAE St. Thd.	SAE St. Thd.

6 USgpm capacity
(Cover end pump)

SAE rating 1200 rpm–100 psi (7 bar)

5 – 5 USgpm	11 – 11 USgpm
8 – 8 USgpm	12 – 12 USgpm
9 – 9 USgpm	14 – 14 USgpm

7 Mounting

F – Foot (Single shaft seal)
S – Flange (Double shaft seal)
Omitted – Flange, single shaft seal assembly

8 Shaft type

1– Straight with square key standard
11– Splined
19– Splined
86– Straight keyed, heavy duty

9 Outlet port positions
(Viewed from cover end of pump)

With # 1 outlet opposite inlet:
AA – # 2 outlet – 135° CCW from inlet
AB – # 2 outlet – 45° CCW from inlet
AC – # 2 outlet – 45° CW from inlet
AD – # 2 outlet – 135° CW from inlet

With # 1 outlet 90° CCW from inlet:
BA – # 2 outlet – 135° CCW from inlet
BB – # 2 outlet – 45° CCW from inlet
BC – # 2 outlet – 45° CW from inlet
BD – # 2 outlet – 135° CW from inlet

9 Outlet port positions continued
(Viewed from cover end of pump)

With # 1 outlet inline with inlet:
CA – # 2 outlet – 135° CCW from inlet
CB – # 2 outlet – 45° CCW from inlet
CC – # 2 outlet – 45° CW from inlet
CD – # 2 outlet – 135° CW from inlet

With # 1 outlet 90° CW from inlet:
DA – # 2 outlet – 135° CCW from inlet
DB – # 2 outlet – 45° CCW from inlet
DC – # 2 outlet – 45° CW from inlet
DD – # 2 outlet – 135° CW from inlet

10 Controlled flow rate
(Models with flow control)

2 – 2 USgpm	8 – 8 USgpm
4 – 4 USgpm	10 – 10 USgpm
6 – 6 USgpm	12 – 12 USgpm
7 – 7 USgpm	

11 Relief valve setting
(Models with flow control)

C – 750 PSI	G – 1750 PSI
D – 1000 PSI	H – 2000 PSI
E – 1250 PSI	I – 2250 PSI
F – 1500 PSI	J – 2500 PSI*

* 20V pump only (not for 12 & 14 ring sizes).

12 Design

13 Rotation
(Viewed from shaft end of pump)

L – Left hand (CCW rotation)
Omitted – Right hand rotation

14 Mounting

282 – SAE 2-bolt mounting
283 – Foot mounting

NOTE

Standard right hand shaft rotation cartridges shown. Reverse for left hand rotation; refer to note.

Cover end cartridge R. H. Rotation

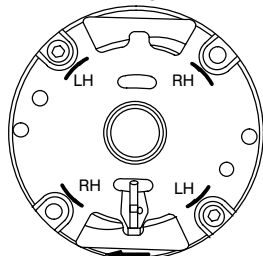

Sharp Edges of Vane Must Lead in Direction of Rotation

Shaft end cartridge R. H. Rotation

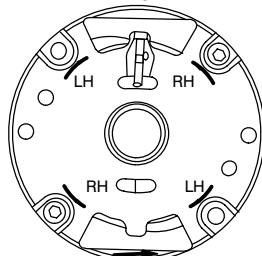

Sharp Edges of Vane Must Lead in Direction of Rotation

NOTE

To reverse cartridge kit rotation, remove the two screws and reverse the location of the inlet support plate and the outlet support plate. Reinstall the two screws hand tight. Use pump cover to align all sections of the cartridge. Carefully remove the cover and tighten the screws.

NOTE

For satisfactory service life of these components, use full flow filtration to provide fluid which meets ISO cleanliness code 16/13 or cleaner. Selections from pressure, return, and in-line filter series are recommended.