

Vickers®

Service Data

Vane Pumps



Vane Type Double Pump

2520VQ Series - 20 Design



Revised 10-01-89

I-3166-S

MODEL	COVER TYPE	COVER S/A
252*VQ*A/F*-****20	4-BOLT	250824
252*VQ*C/E*-****20	STRAIGHT THREAD	252504
252*VQ*C/E*-**2*20	FLOW CONTROL	257560
252*VQ*C/E*-**4*20		257561
252*VQ*C/E*-**6*20		257562
252*VQ*C/E*-**7*20		257563
252*VQ*C/E*-**8*20		257564
252*VQ*C/E*-**10*20		257565
252*VQ*C/E*-**12*20		257999

MODEL	RELIEF VALVE SETTING (PSI)	RELIEF VALVE S/A
252*VQ***-***C20	750	232794
252*VQ***-***D20	1000	232795
252*VQ***-***E20	1250	232796
252*VQ***-***F20	1500	232797
252*VQ***-***G20	1750	232798
252*VQ***-***H20	2000	232799
252*VQ***-***J20	2250	233019
252*VQ***-***K20	2500	233020

**20VQ MODELS ONLY NOT FOR 12 & 14 RING SIZES.

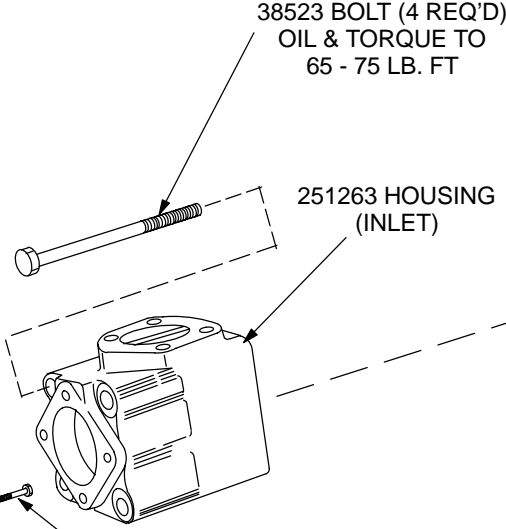
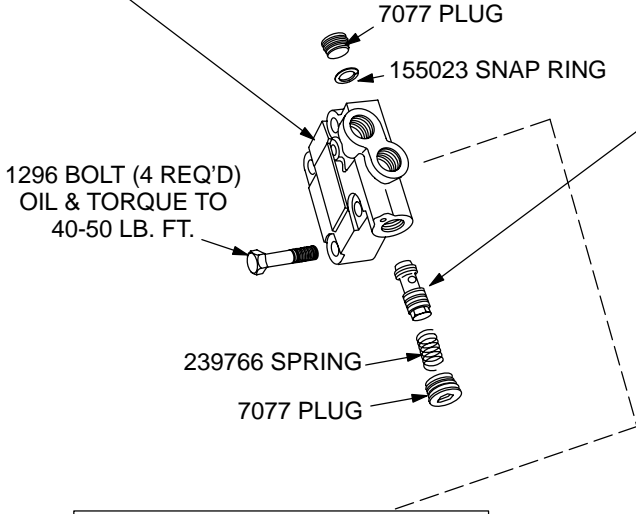

***NOTE**
INSTALL INTO COVER BEFORE INSTALLATION OF CARTRIDGE KIT.

NOTE
BRONZE FACES MUST BE INSTALLED TOWARD THE ROTOR.

TORQUE TO 30 ± 5 LB. IN.

© Vickers, Incorporated 1996
All Rights Reserved

MODEL	▲ BACK-UP RING	▲ "O" RING	▲ SEAL RING	▲ "O" RING	OUTLET SUPPORT PLATE	▲ SEAL PACK (4 REQ'D)	■ FLEX-SIDE PLATE KIT	ROTOR	VANE KIT (10 VANES & 10 INSERTS)	RING	INLET SUPPORT PLATE	PIN (2 REQ'D)	SCREW (2 REQ'D)	CART. KIT	F3 CART. KIT						
THESE PARTS ARE INCLUDED IN CARTRIDGE KIT																					
2*20*** 5**	588506	154026	419672	154090	419500	433762 S/A	923955	402690	922741	333624	419502	422206	416426	417053	421588						
2*20*** 8**										333625						417054	421589				
2*20*** 9**										374799						423096	423097				
2*20*** 11*										333626						416427	421590				
2*20*** 12*								403539	922743	353901	419501					416428	421591				
2*20*** 14*										353902						416429		421592			
2*21*** 5**◇								428698	922741	333624	419502					428700	428707				
2*21*** 8**◇										333625						428701		428708			
2*21*** 9**◇										374799						428702		428709			
2*21*** 11**◇										333626						428703		428710			
2*21*** 12**◇										428699						922743		353901	419501	428704	428711
2*21*** 14*◇																		353902		428705	

◇ VQ REPLACEMENT CARTRIDGES FOR THE 2521 SERIES.

● ASSEMBLE SEAL FLUSH TO PILOT FACE WITH SPRING FACING INWARD AS SHOWN.

○ ASSEMBLE SEAL WITH SPRING TOWARD BEARING.

USE THE REPLACEMENT PARTS SHOWN ON THIS DRAWING TO SERVICE A 2520V-10/12 UNIT. CARTRIDGES MUST BE REPLACED AS A KIT. INDIVIDUAL PARTS OF A CARTRIDGE ARE NOT INTERCHANGEABLE.

□ WIPE O.D. OF SEAL WITH OIL BEFORE PRESSING INTO BODY. APPLY GREASE TO SEAL I.D. BEFORE INSTALLATION OF SHAFT.

⊖ INCLUDED IN FOOT BRACKET KIT FB-B-10

SHAFT NO.	TYPE	SECONDARY SHAFT SEAL	2*20 SHAFT	2*21 SHAFT	KEY
1	STR. KEYED	—	254964	252737	955
11	SPLINE	—	254848	252736	—
123	SPLINE	429283	413433	—	—

△ □ ○ SECONDARY SHAFT SEAL (SEE TABLE)

▲ □ ○ 394976 PRIMARY SHAFT SEAL

MODEL	LOCK RING	RETAINING RING	BRG.
252*VQ*****_***20	191400	120128	1705
252*VQ*****_***20			232750

NOTE
BRONZE FACES MUST BE INSTALLED TOWARD THE ROTOR.

TORQUE TO 45 ± 5 LB. IN.

MODEL	BODY	TYPE
2*2*VQ*A/E*_**20	942353	4-BOLT
2*2*VQ*C/F*_**20	942378	STR THD

STD/F3 SEAL KITS			
△ STD SINGLE SHAFT	△▲ STD DOUBLE-SHAFT	F3 SINGLE SHAFT	F3 DOUBLE SHAFT
920040	920041	920042	920043

MODEL	SCREW (2 REQ'D)	PIN (2 REQ'D)	INLET SUPPORT PLATE	▲ SEAL PACK (4 REQ'D)	■ FLEX-SIDE PLATE KIT	ROTOR	VANE KIT (10 VANES & 10 INSERTS)	RING	OUTLET SUPPORT PLATE	“O” RING	*▲ SEAL RING	“O” RING	▲ BACK-UP RING	CART. KIT	F3 CART. KIT
THESE PARTS ARE INCLUDED IN CARTRIDGE KIT															
2*2*VQ12	413834	422207	430805 S/A	433764 S/A	923956	270597	922710	326984	419079	154095	416973	154078	588507	416439	421570
2*2*VQ14								326985						416440	421571
2*2*VQ17								326986						416441	421572
2*2*VQ19								326987						421232	421573
2*2*VQ21								326988						416442	421574

*INSTALL SEAL RING IN BODY OR COVER, THEN INSTALL CARTRIDGE KIT

■ NOTE: FLEX SIDEPLATE KITS INCLUDE (4) F3 SEAL PACKS.

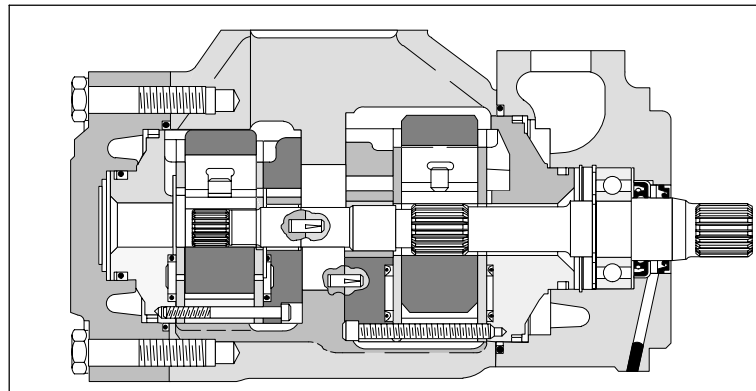

199491 BRACKET

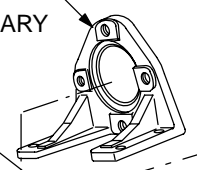

199740 SCREW (2 REQ'D)

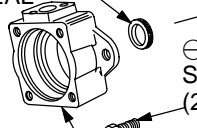

190362 WASHER

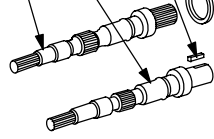

Model Code

(F3) - 2520 VQ ** A ** - * 1 ** ** * 20 (*) - 28 *

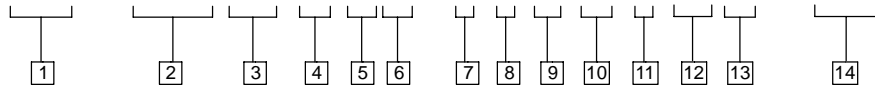

1 Viton seals
(Omit if not required.)

2 Series designation

2520VQ, Double Pump
2620VQ, Double Pump

3 Intra-vane pump

4 USgpm capacity
(Shaft end pump)

SAE rating 1200 rpm–100 psi (7 bar)

12 – 12 USgpm	19 – 19 USgpm
14 – 14 USgpm	21 – 21 USgpm
17 – 17 USgpm	

5 SAE port connections

Models Without Flow Control

Code	Inlet	Outlet #1	Outlet #2
A –	4 bolt flange	4 bolt flange	4 bolt flange
C –	4 bolt flange	SAE St. Thd.	SAE St. Thd.
E –	4 bolt flange	4 bolt flange	SAE St. Thd.
F –	4 bolt flange	4 bolt flange	SAE St. Thd.

Models With Flow Control

Code	Inlet	Outlet #1	Outlet #2	Tank Return
C –	4 bolt flange	SAE St. Thd.	SAE St. Thd.	SAE St. Thd.
E –	4 bolt flange	4 bolt flange	SAE St. Thd.	SAE St. Thd.

6 USgpm capacity
(Cover end pump)

SAE rating 1200 rpm–100 psi (7 bar)

5 – 5 USgpm	11 – 11 USgpm
8 – 8 USgpm	12 – 12 USgpm
9 – 9 USgpm	14 – 14 USgpm

7 Mounting

F – Foot (Single shaft seal)

S – Flange (Double shaft seal)

Omitted – Flange, single shaft seal assembly

8 Shaft type

1– Straight with square key standard
11– Splined
123– Splined

9 Outlet port positions

(Viewed from cover end of pump)

With # 1 outlet opposite inlet:

AA – # 2 outlet – 135° CCW from inlet

AB – # 2 outlet – 45° CCW from inlet

AC – # 2 outlet – 45° CW from inlet

AD – # 2 outlet – 135° CW from inlet

With # 1 outlet 90° CCW from inlet:

BA – # 2 outlet – 135° CCW from inlet

BB – # 2 outlet – 45° CCW from inlet

BC – # 2 outlet – 45° CW from inlet

BD – # 2 outlet – 135° CW from inlet

9 Outlet port positions continued
(Viewed from cover end of pump)

With # 1 outlet inline with inlet:

CA – # 2 outlet – 135° CCW from inlet

CB – # 2 outlet – 45° CCW from inlet

CC – # 2 outlet – 45° CW from inlet

CD – # 2 outlet – 135° CW from inlet

With # 1 outlet 90° CW from inlet:

DA – # 2 outlet – 135° CCW from inlet

DB – # 2 outlet – 45° CCW from inlet

DC – # 2 outlet – 45° CW from inlet

DD – # 2 outlet – 135° CW from inlet

10 Controlled flow rate

(Models with flow control)

2 – 2 USgpm	8 – 8 USgpm
4 – 4 USgpm	10 – 10 USgpm
6 – 6 USgpm	12 – 12 USgpm
7 – 7 USgpm	

11 Relief valve setting

(Models with flow control)

C – 750 PSI	G – 1750 PSI
D – 1000 PSI	H – 2000 PSI
E – 1250 PSI	I – 2250 PSI
F – 1500 PSI	J – 2500 PSI*

* 20V pump only (not for 12 & 14 ring sizes).

12 Design

13 Rotation

(Viewed from shaft end of pump)

L – Left hand (CCW rotation)

Omitted – Right hand rotation

14 Mounting

282 – SAE 2-bolt mounting

283 – Foot mounting

NOTE

Standard right hand shaft rotation cartridges shown. Reverse for left hand rotation; refer to note.

Cover end cartridge R. H. Rotation

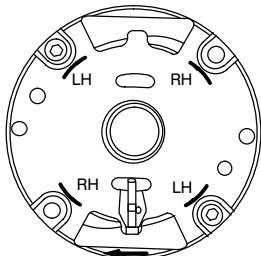

Sharp Edges of Vane Must Lead in Direction of Rotation

Shaft end cartridge R. H. Rotation

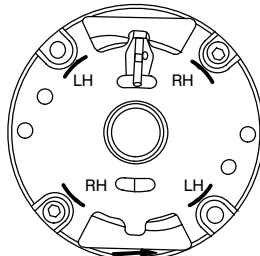

Sharp Edges of Vane Must Lead in Direction of Rotation

NOTE

To reverse cartridge kit rotation, remove the two screws and reverse the location of the inlet support plate and the outlet support plate. Reinstall the two screws hand tight. Use pump cover to align all sections of the cartridge. Carefully remove the cover and tighten the screws.

NOTE

For satisfactory service life of these components, use full flow filtration to provide fluid which meets ISO cleanliness code 16/13 or cleaner. Selections from pressure, return, and in-line filter series are recommended.